

DATA SHEET

FT2 BOW THRUSTER

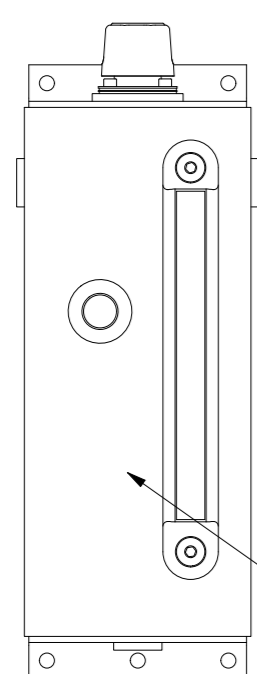

GRAVITY TANK

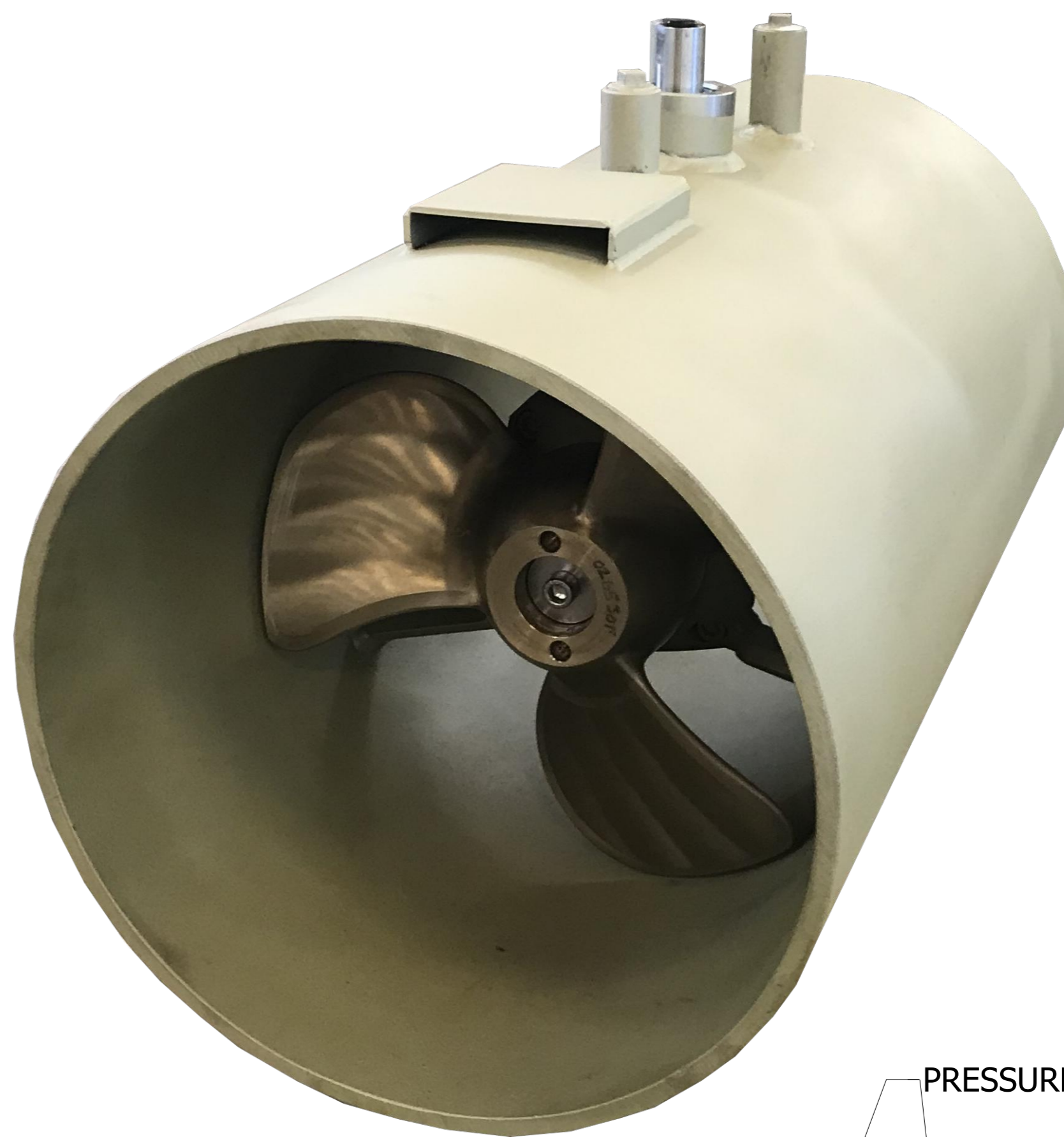
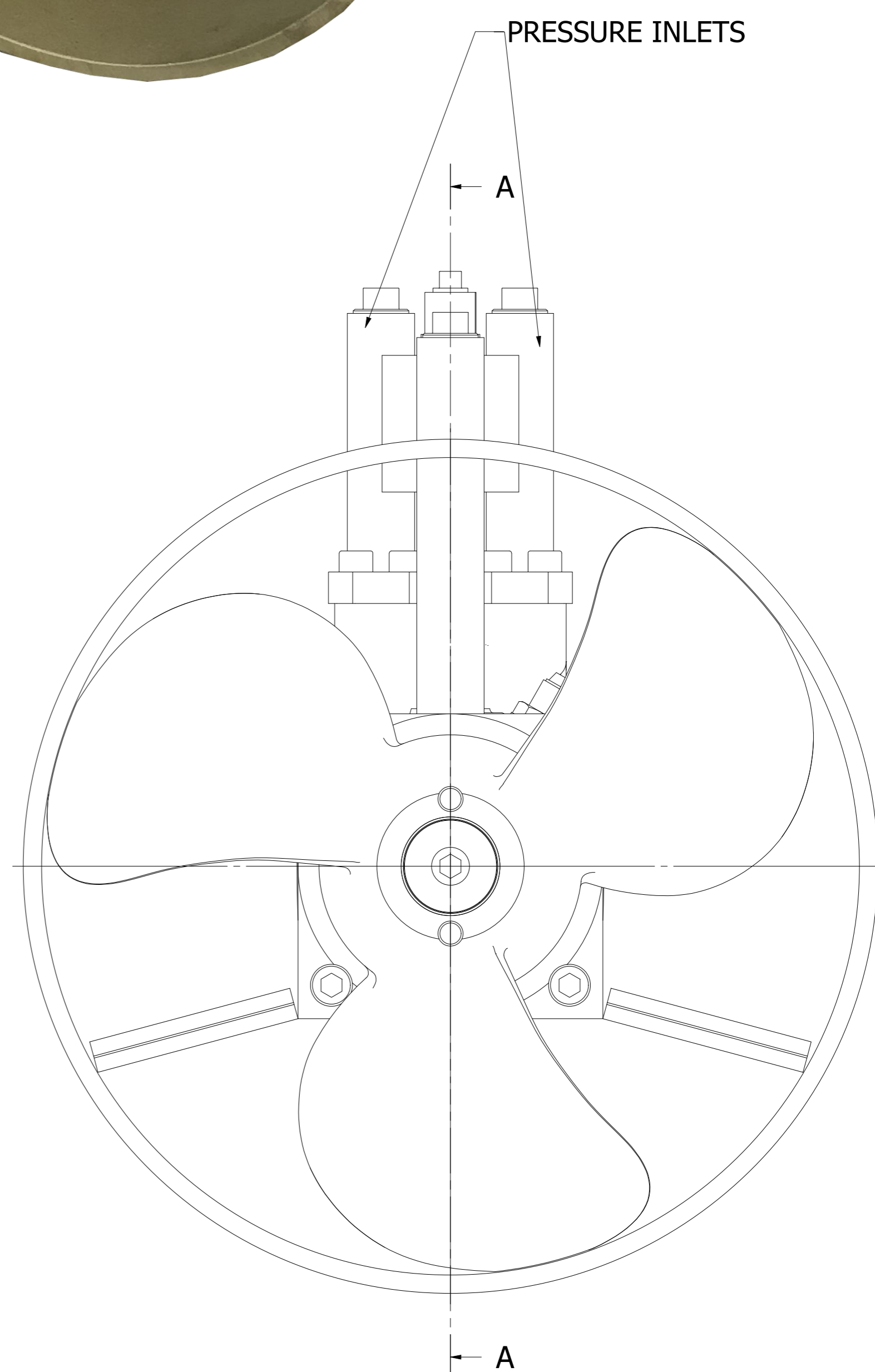
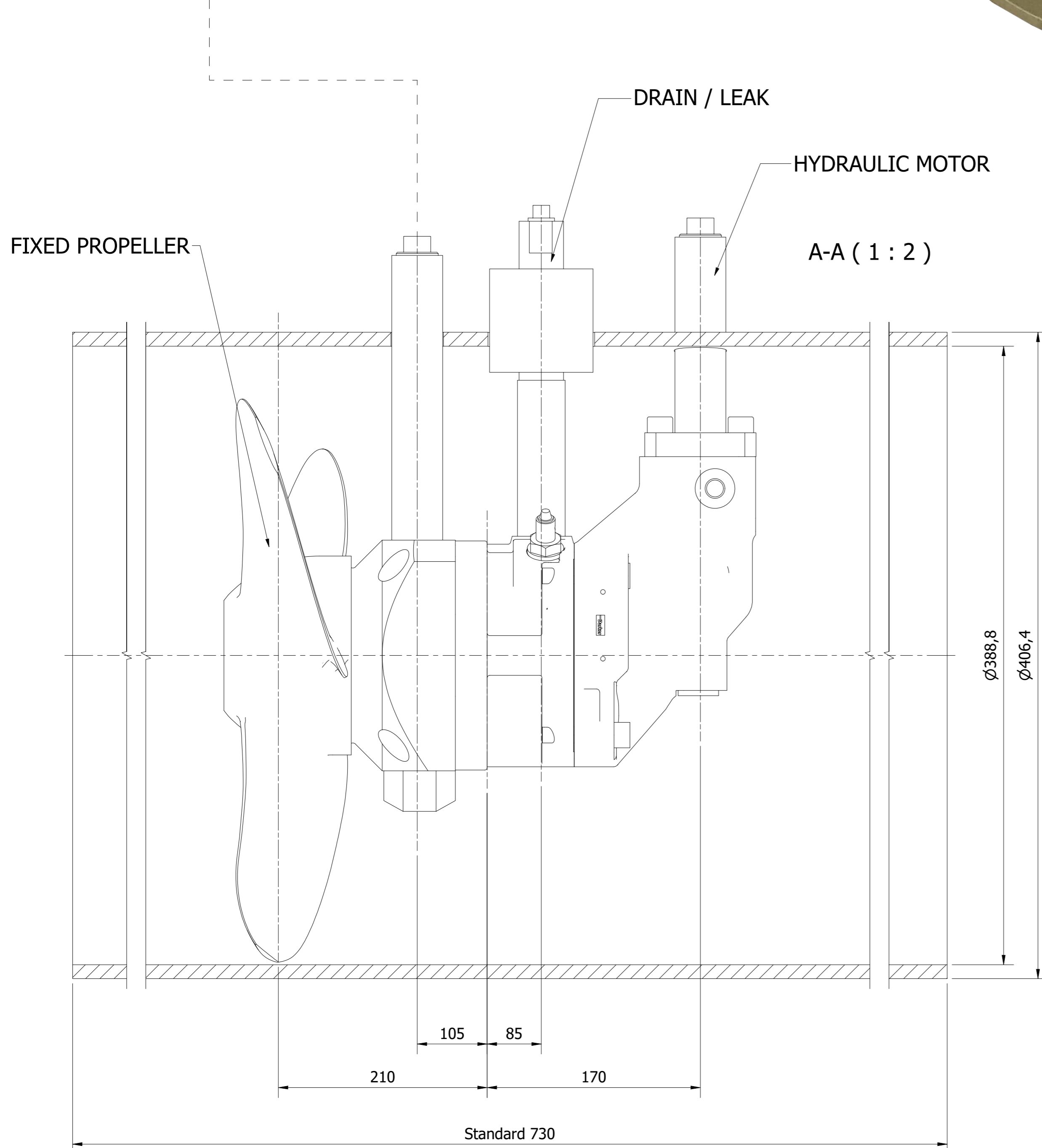

Max. power : 50 HP (37 kW)

Max. motor Rpm : 1500 Rpm

Hydraulic flow : 95 L/min

Hydraulic pressure : 260 bar.

Max. thrust : Approx. 105 N/HP - 5250N

Displacement of motor 60 cm³ / rev.

Overall weight, at 730 mm thruster tunnel, 125 kg.



1-048-033657-1

HUNDESTED  **PROPELLER A/s**

E-mail: sales@hundested.com