

DATA SHEET

FR-ELH Pitch Control Unit

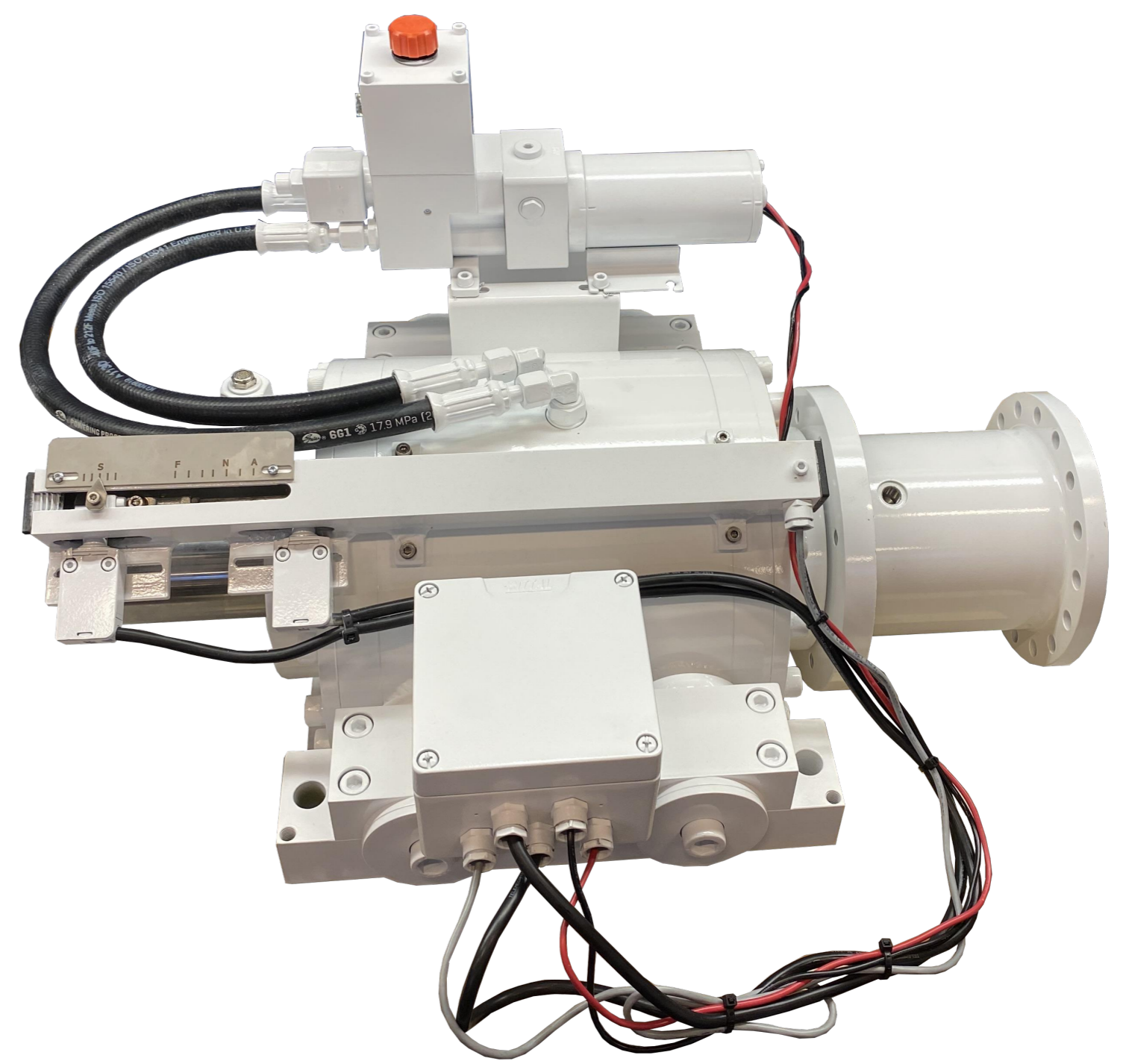
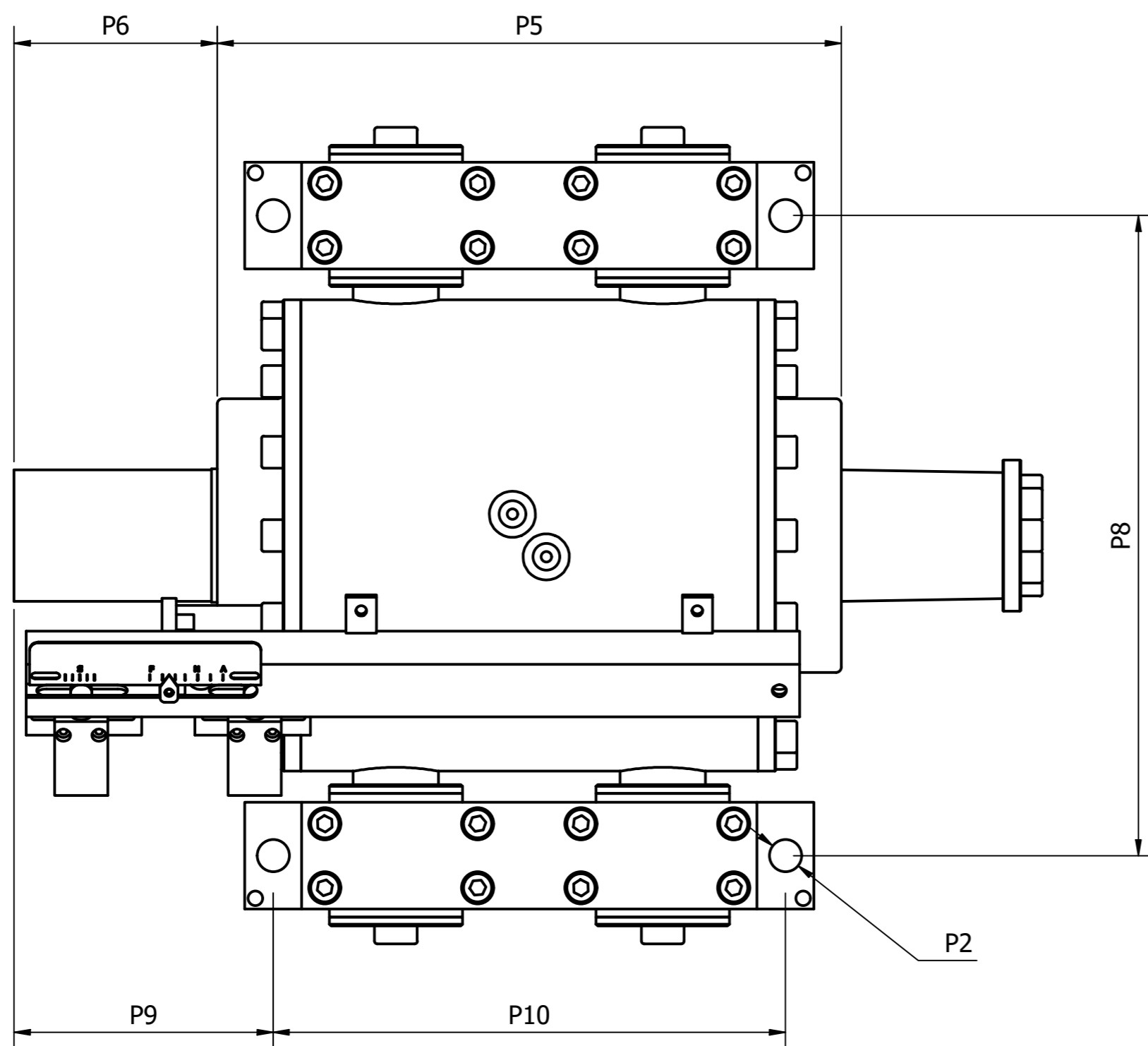
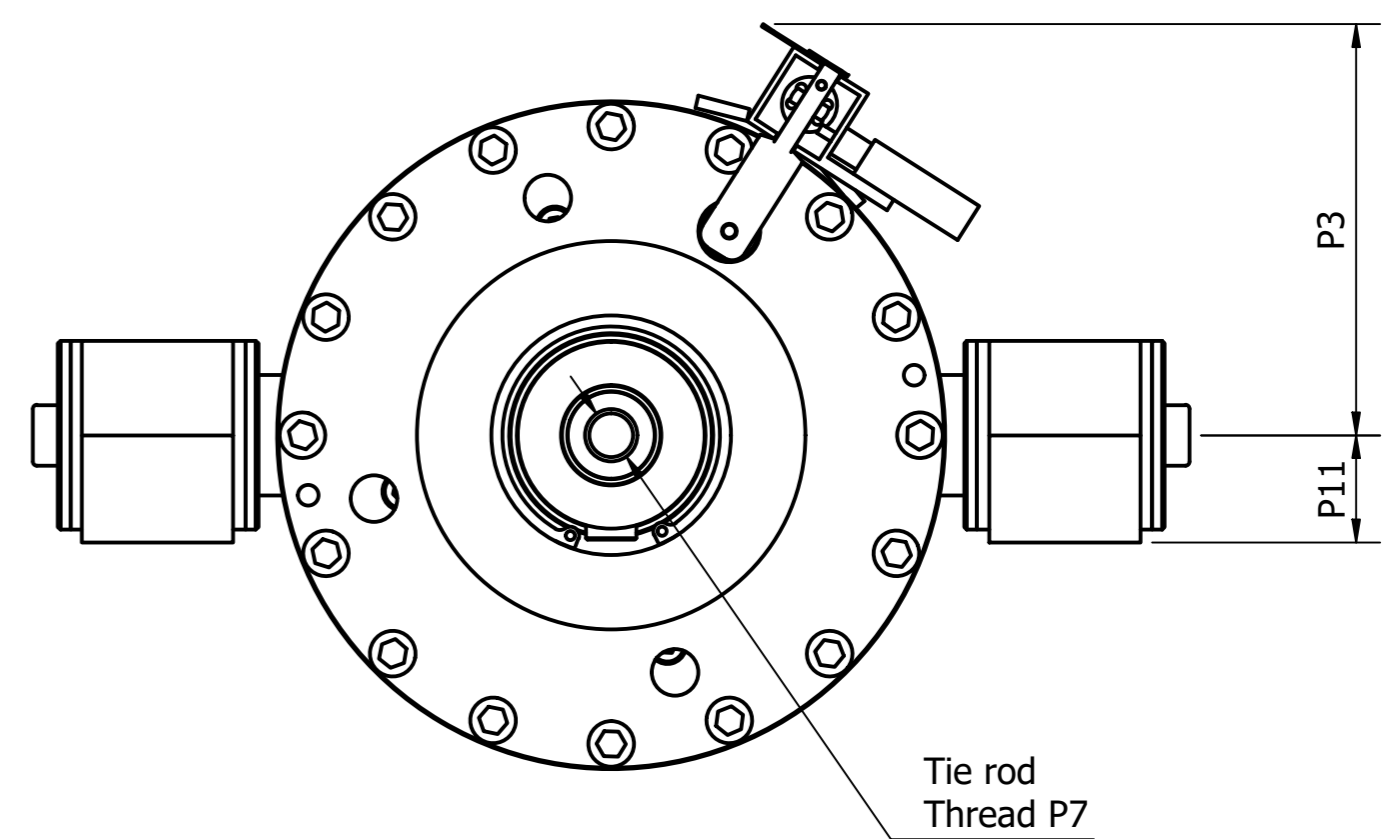
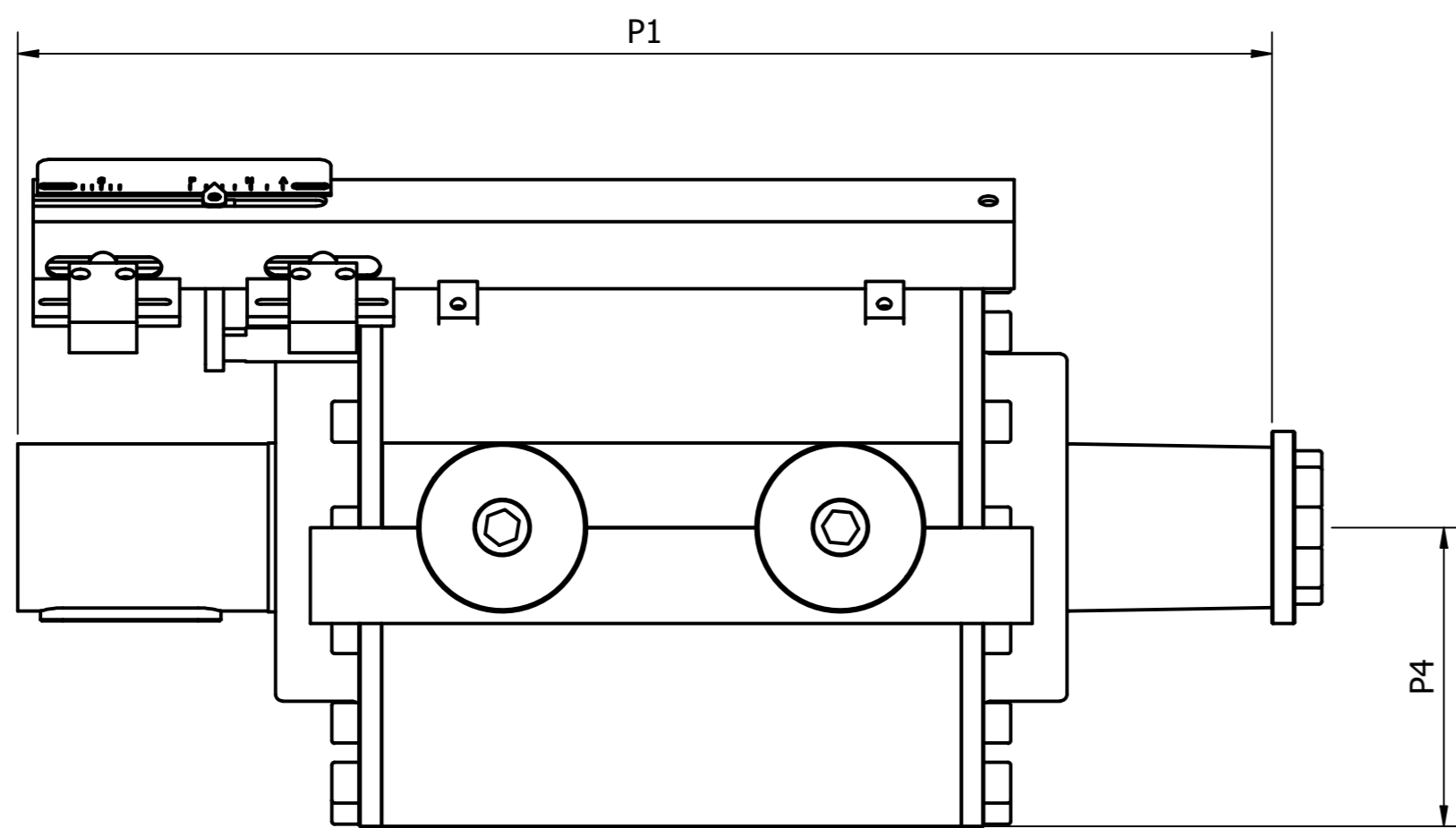

VP	3	4	5	6	7	8	9	10
P1 (mm)	556	556						
P2 (mm)	Ø18	Ø18						
P3 (mm)	163	163						
P4 (mm)	132,5	132,5						
P5 (mm)	351	351						
P6 (mm)	114,2	114,2						
P7 (mm)	M20	M24						
P8 (mm)	360	360						
P9 (mm)	145,7	145,7						
P10 (mm)	288	288						
P11 (mm)	42,5	42,5						
Weigth (kg)	110	110						
Stroke (mm)	85	85						
Working pressure (bar)	10-30	10-30						
Max. Pressure (bar)	50	50						
Tie rod force (kN)	40	40						

The FR-ELH pitch control unit is delivered with thrust bearing and semi flexible mounts built in, and is supplied with necessary hydraulic components.



HUNDESTED PROPELLER A/S

E-mail: sales@hundested.com

1-048-032730-0