

FT4R BOW THRUSTER

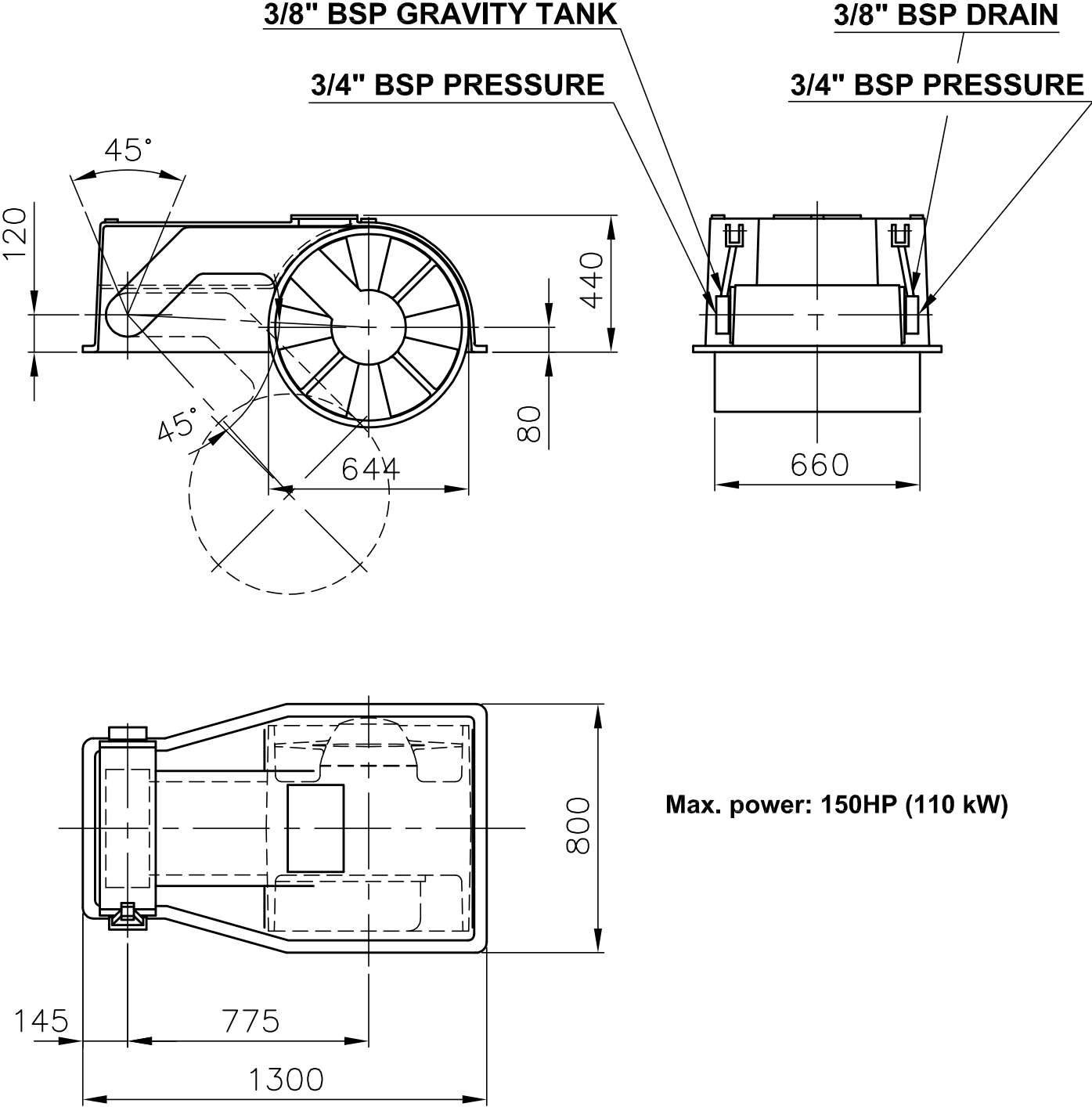

4-048-15700-01

STANDARD SPEC. RETRACTABLE THRUSTERS

TYPE FT-R

Tunnel and housing in aluminum; AlMg5Si

Fixed 3 or 4-bladed propeller in aluminum; AlMg5Si

Down angle 45-55 degrees

Built-in hydraulic motor

Electric or hydraulic actuator for UP/DOWN function

Gravity tank