

CPT 11 BOW THRUSTER

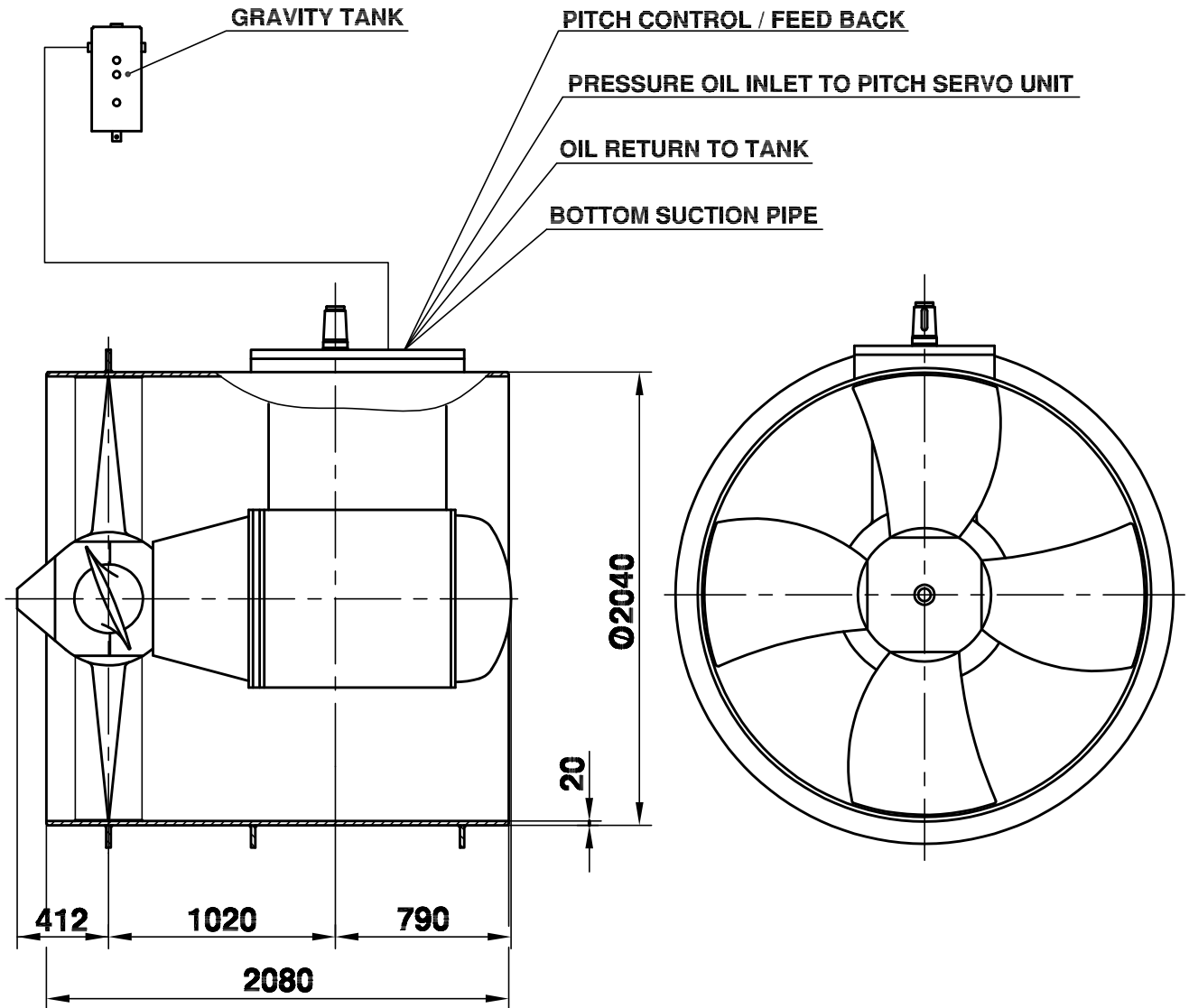

Max. power : 1360 HP (1000 kW)

Max. motor Rpm : 1800 Rpm

Gear ratio : Std. 4,89:1

Max. thrust : Approx. 140 kN

Overall weight, at 2080 mm thruster tunnel, approx. 7000 Kg.

4-048-15150-00