

DATA SHEET

MARINEGEAR CPG280

With safety according to class

Gear ratios	Torque [Nm]	J-Factor [kW/rpm]	J-Factor [HP/rpm]
3,06 : 1	28000	2,93	3,98
3,48 : 1	28000	2,93	3,98
4,04 : 1	26370	2,76	3,75
4,52 : 1	23550	2,47	3,35
4,95 : 1	21000	2,20	2,99
5,55 : 1	16800	1,76	2,39
6,06 : 1	14610	1,53	2,08
6,58 : 1	12410	1,30	1,77

OTHER RATIOS AVAILABLE ON REQUEST

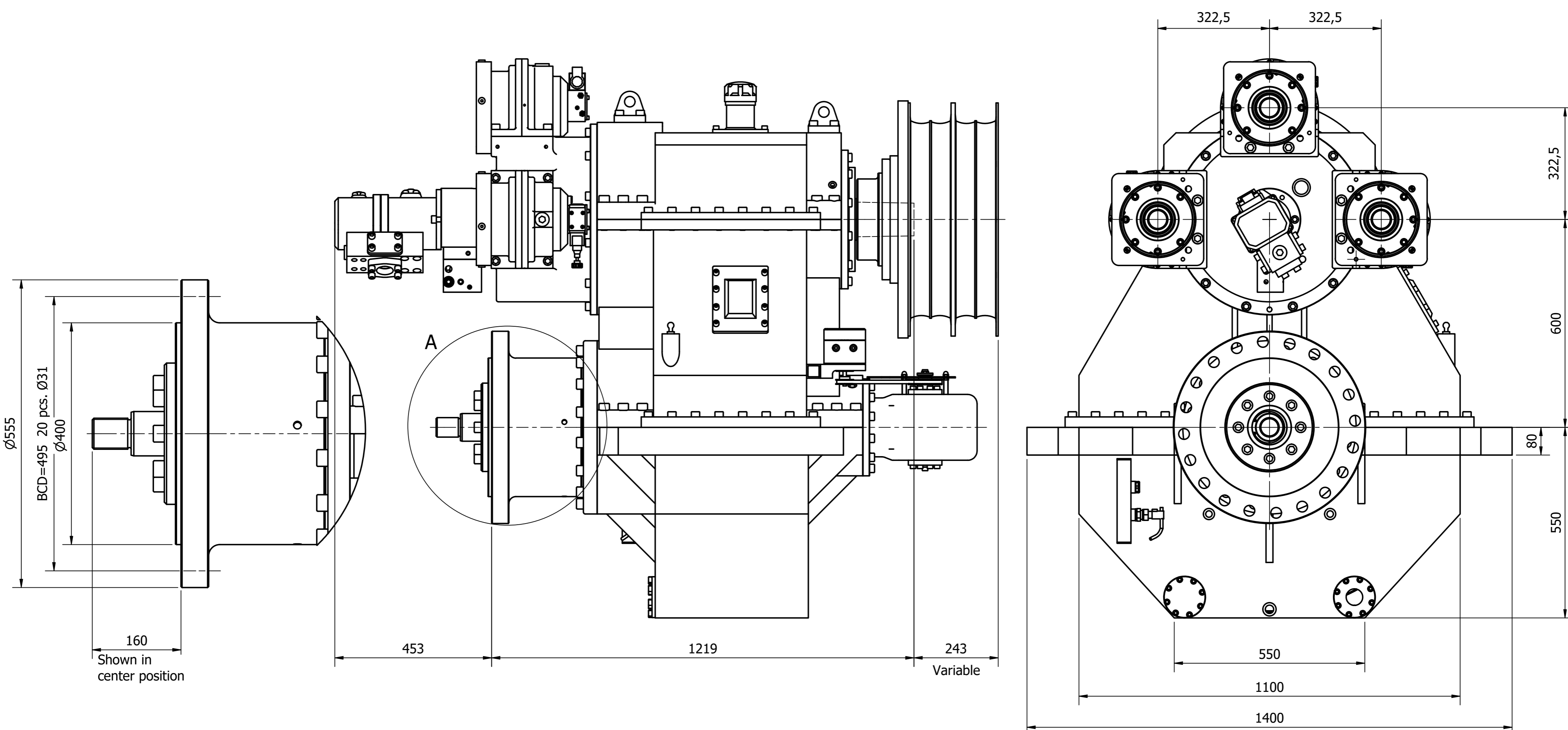

Servo for propeller:

- Max. force: 51,2t
- Max. stroke 200mm
- Suitable for feathering propeller

Options:

- Semi flexible foundation
- Semi flexible output coupling

PTO standard specifications:

- Max. 3 PTO's - each with hydraulic clutch or as live PTO.
- Max. torque f. 1 PTO: 2000Nm
- Max. total torque: 6000Nm
- Rpm speed-up ratio: 1,69:1
- SAE-C / SAE-D / SAE-E flange
- other PTO & flanges available on request

Weight (Approx.):

- Weight without PTO: 4000kg
- Weight with 3 PTO's: 4200kg

Direction of rotation:

- Single step gearbox
- Standard left in / right out



1-048-032189-0

HUNDESTED | **PROPELLER A/s**

E-mail: sales@hundested.com