

Propeller 18" – 20" Overdrive for shaft

Propeller 22" – 24" – 26" Overdrive for shaft

Propeller 28" – 30" Overdrive for shaft

- 1) OPERATING INSTRUCTIONS 3-blade Gori Folding Overdrive Propeller
- A) Disassemble complete propeller hub for mounting
- B) Assemble hub on shaft
- C) Exchange of "rubber blade stop"
- D) Exchange of "zinc anodes"
- E) Cleaning of "Gearwheel"
- F) Service sets & Spare Parts List
- G) Supplied Tools

DK

Læs instruktionen før der arbejdes med propellen.

Vigtigt!

Udskift zink hvis de er korroderet mere end 50%.

Advarsel!

Pas på skarpe kanter.

GB

Read the Instructions before any work on the propeller.

Important!

Replace Zinc if eroded more than 50%.

Warning!

Beware of sharp edges.

D

Bitte die Anweisung lesen, bevor Sie mit dem Propeller arbeiten.

Wichtig!

Zinkteile auswechseln, wenn sie mehr als 50% korrodiert sind.

Warnung!

Achten Sie auf die scharfe Kanten.

F

Lire les instructions avant toute intervention sur l'hélice

Important!

Remplacer l'anode zinc si elle est corrodé à plus de 50%

Attention!

Attention aux bords coupants

IT

Leggere attentamente le Istruzioni prima di qualsiasi operazione sull'elica.

Importante!

Sostituire l'anodo di zinco se usurato più del 50%

Avvertenza!

Prestare attenzione alle parti taglienti

ESP

Lea las instrucciones antes de efectuar cualquier trabajo en la hélice.

¡ Importante !

Reemplazar el ánodo si observa mas de un 50 % de corrosión.

¡ Advertencia !

Tenga cuidado con las esquinas afiladas.

OPERATING INSTRUCTIONS 3-blade Gori Folding Overdrive Propeller

CONGRATULATIONS on choosing the 3-blade Gori Folding Propeller.

The 3-blade Gori folding overdrive propeller has been designed in such a way that if the propeller is in "overdrive" position, the boat will attain approximately the same speed at lower engine revolutions.

Do not press the engine to the utmost as this will result in overloading.

Do only use the overdrive function when motoring in calm weather and when using the engine under sail.

Gori Propeller disclaim the responsibility for any damage caused by overloading the engine. In case of doubt about the loading of the engine, you should contact the authorised engine service organisation and Gori Propeller.

Under sail

When sailing under sail the blades usually fold, however, you should put the lever in reverse if the engine is not turned on. This will lock the shaft and ensure that the propeller folds and does not spin.

Ahead

The propeller usually opens in forward position unless the boat has just been in reverse.

If you want to shift from "overdrive" to forward position, the lever will have to be put into neutral when the boat does more than 1 knot ahead, until the blades have folded again. Then in forward position again.

In case of harbour manoeuvres the propeller might get into "overdrive" position. Therefore, before leaving the harbour, please always check the position of the propeller by means of the tachometer so that the propeller is in the wanted position.

Astern

In the reverse position the blades swing 180° opposite the forward position which ensures the same blade leading edge and profile – resulting in high efficiency. If the boat has not been used for some time, you should shift cautiously between forward and reverse a few times before sailing in order to clean the teeth of the blades and the gears from fouling.

Ahead "Overdrive"

In order to position the propeller in forward "overdrive" it is necessary to move the boat astern so that the blades are kept in reverse position when the lever is put into forward. Do not try to make the propeller go from forward to "overdrive" position by quick shifts with the lever when the boat is sailing ahead in the water.

Before going sailing, check that the propeller works in both forward and reverse.

WARNING !

- **Do not start the engine when the boat is out of the water.**
- **The propeller has sharp edges. Be careful not to cut your fingers !**
- **Make sure that the propeller blades do not suddenly open or close and trap your fingers for example.**
- **Do not turn the propeller/engine shaft until the boat is in the water.**
- **Stop the engine before diving or swimming in the vicinity of the boat.**
- **The propeller blades are like knives and can cause considerable damage when rotating. Be careful!**
- **Do not attempt to remove fishing net or ropes from the propeller when the engine is in motion.**
- **Check that the propeller works in both forward and reverse before starting each trip.**
- **If any strange sounds or vibration are noticed coming from the propeller, stop the engine immediately and solve the problem.**
- **In case of problems in connection with the mounting, use or function of the propeller, contact Gori Propeller or the importer in your country.**

Disassemble complete propeller hub for mounting – (A)

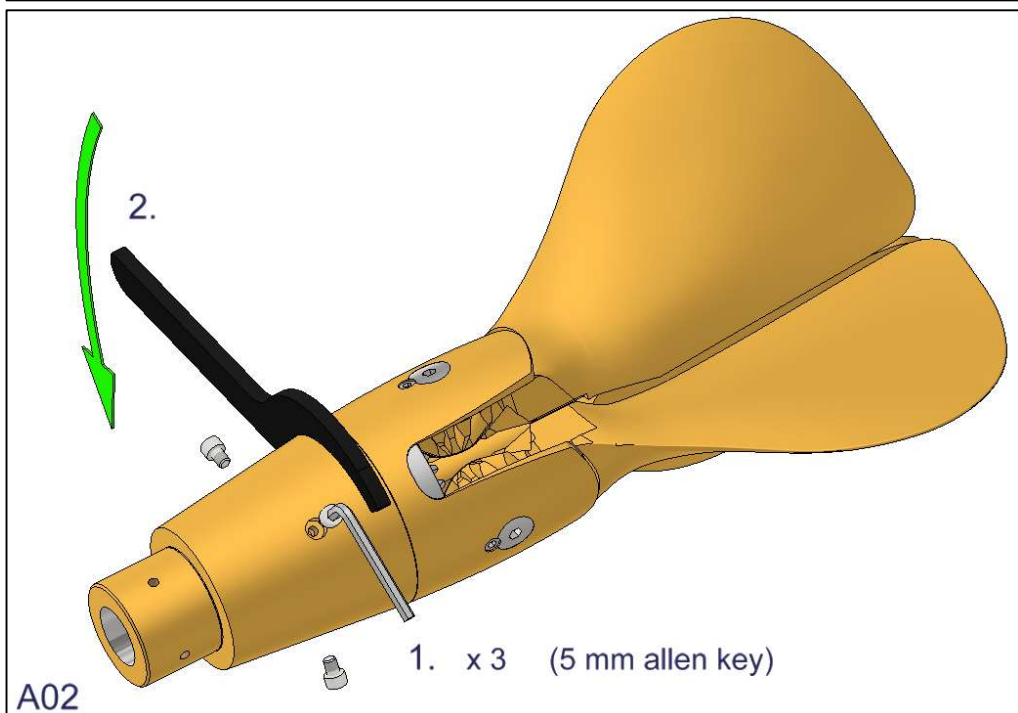
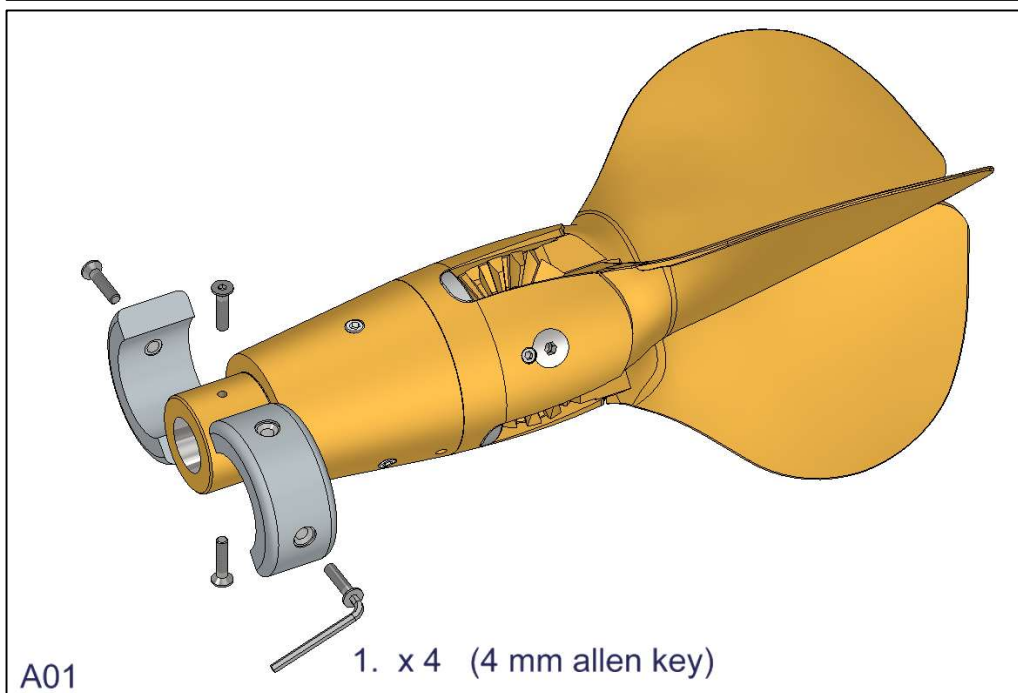
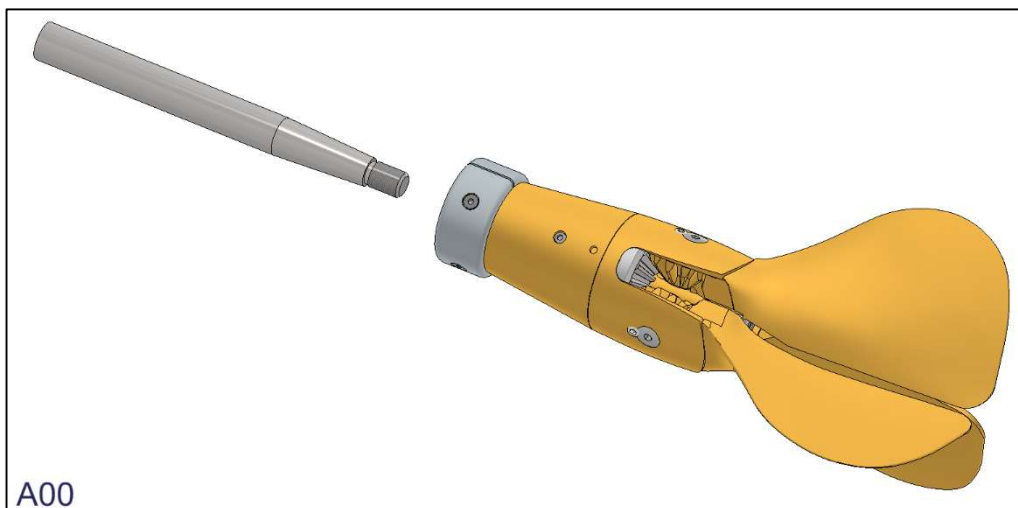

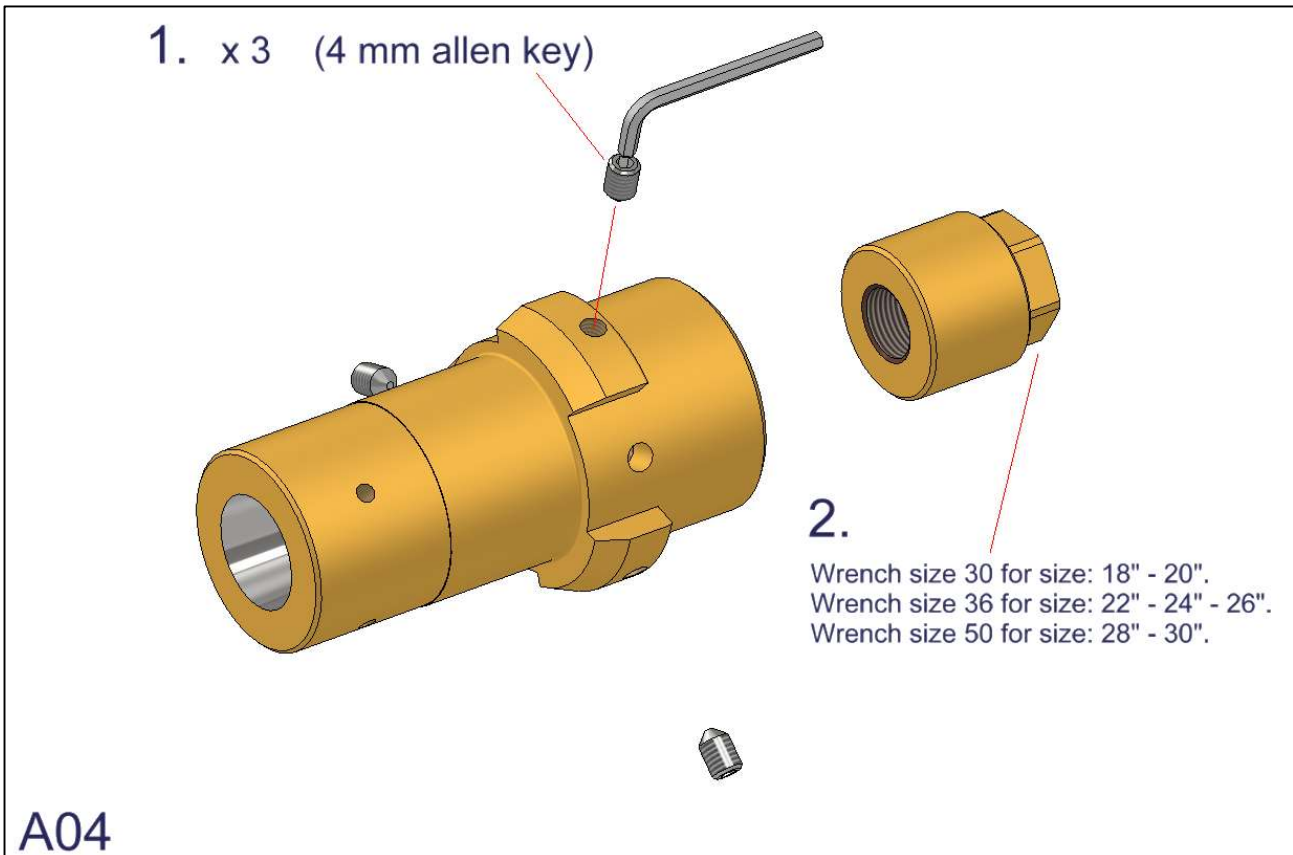
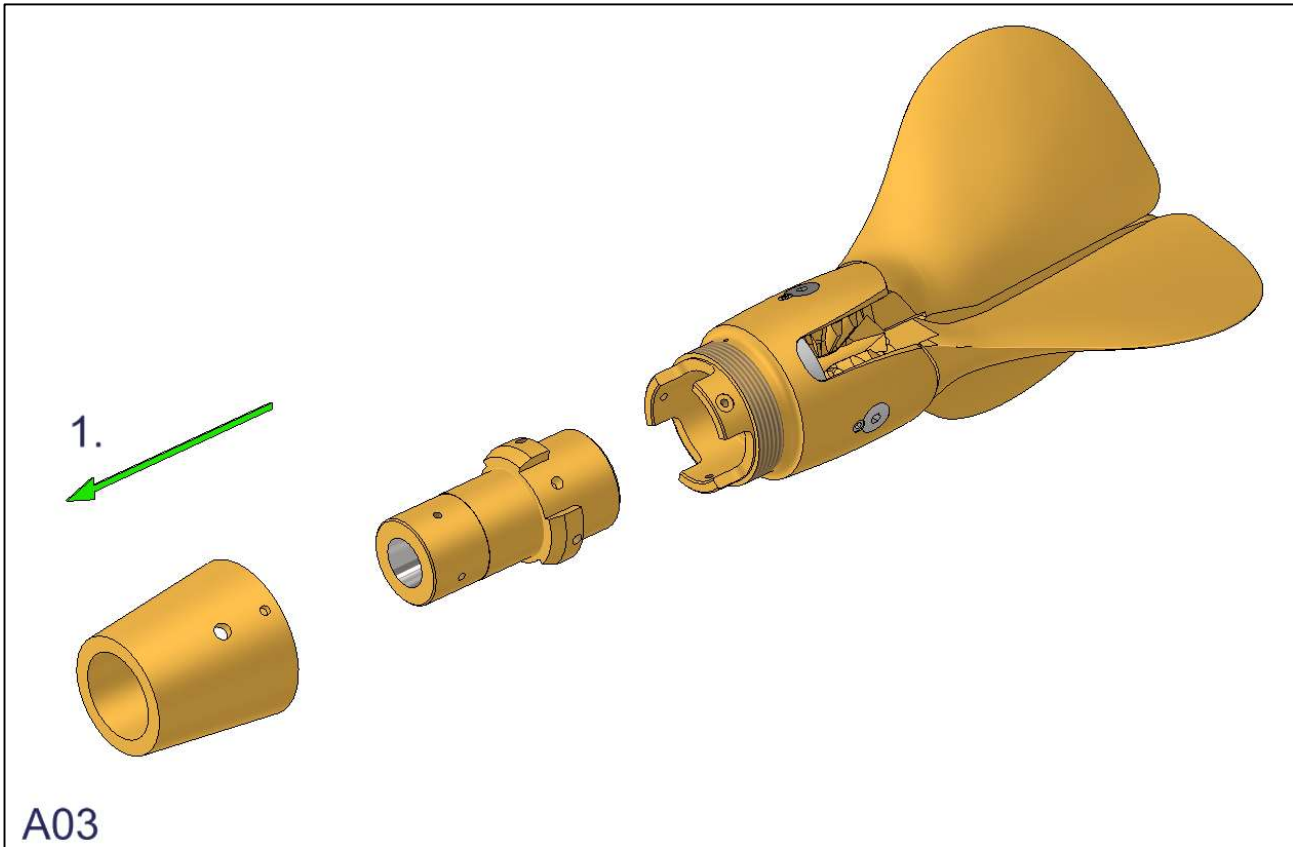

Assemble hub on shaft – (B)

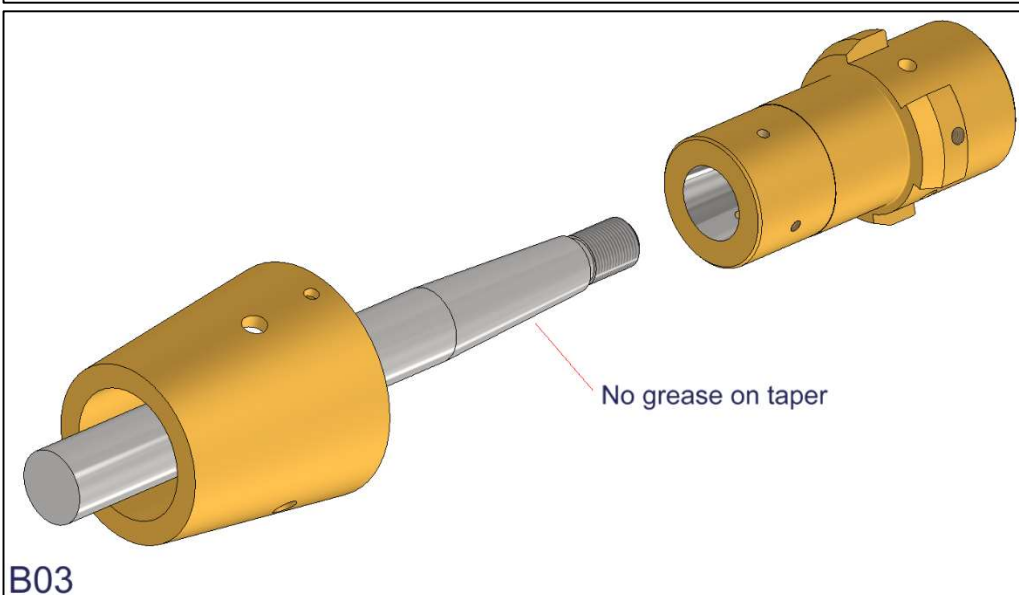
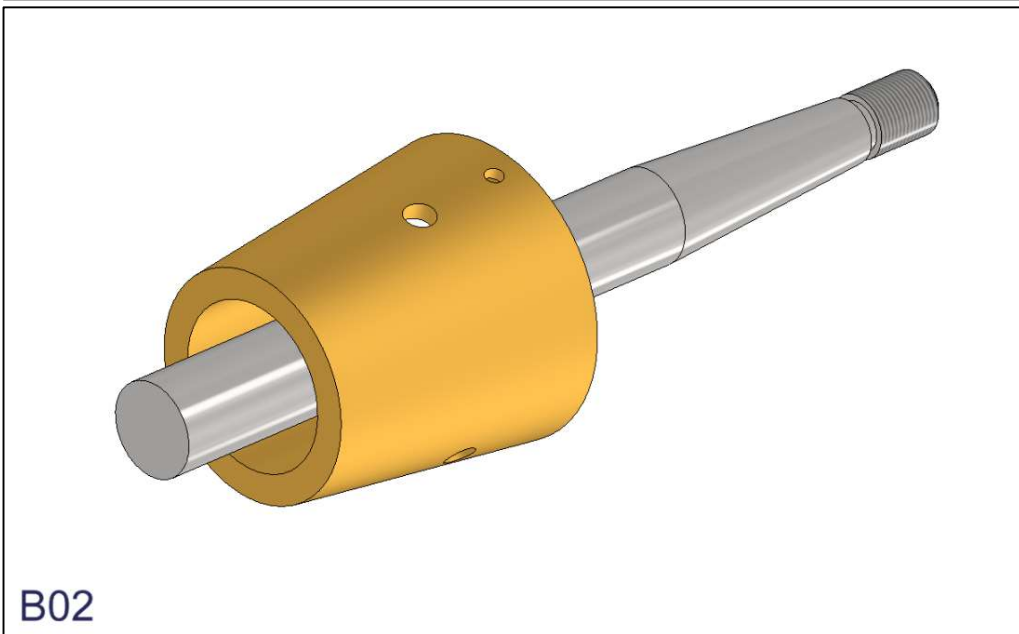
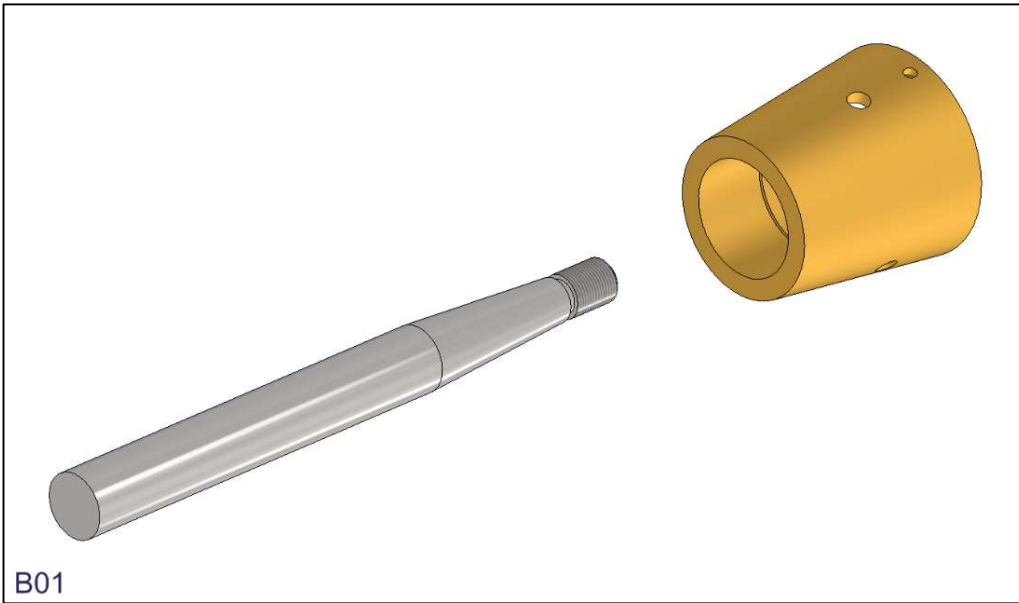

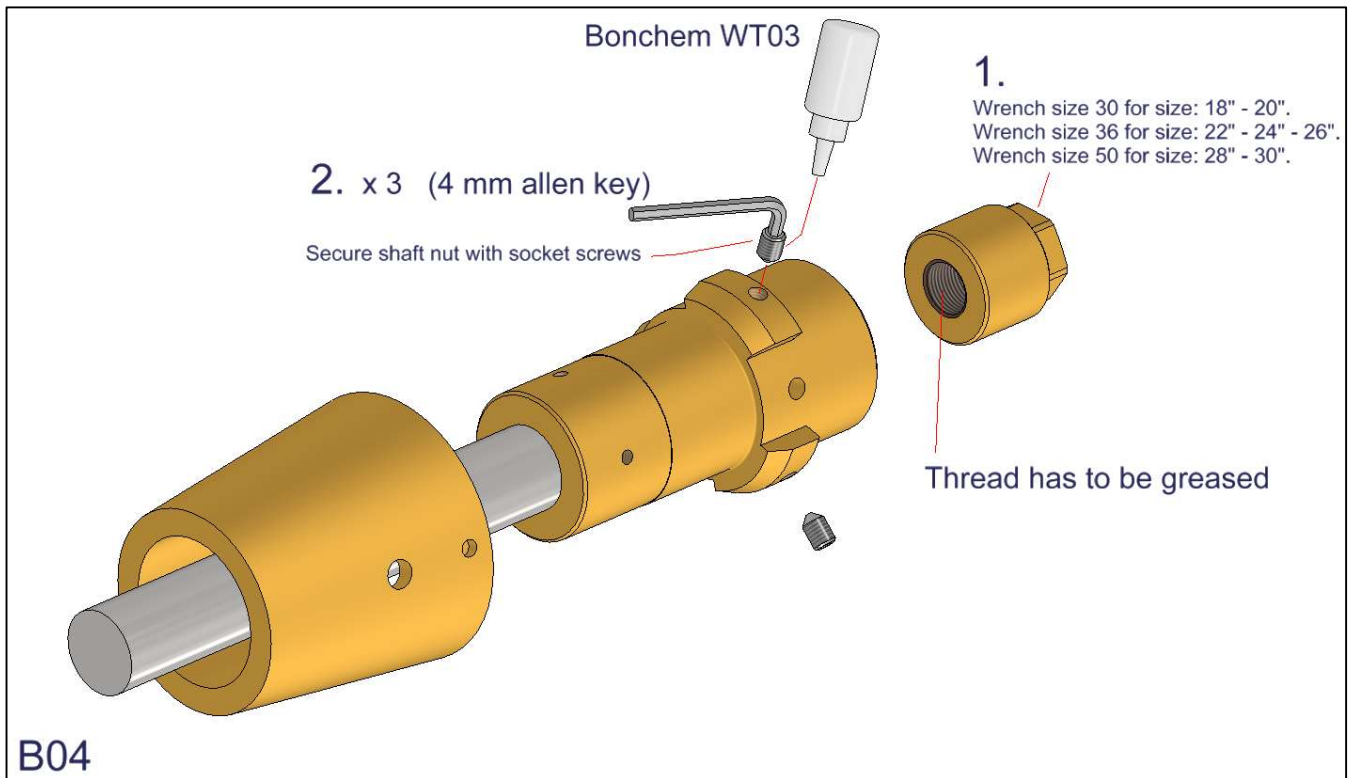

Torque settings for Gori shaft nuts in Nm

Norm Thread		Torque
Diameter	Pitch	
mm	mm	Nm
Table: See section "F".		

Thread has to be greased
No grease on taper on shaft

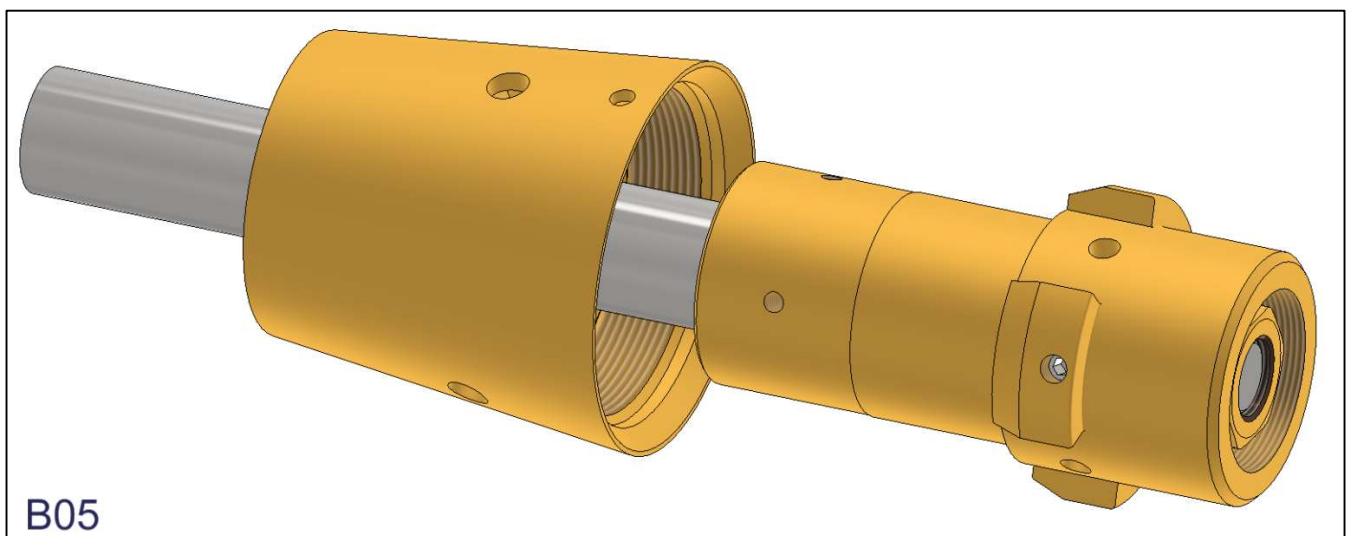

Assemble hub on shaft – (B)

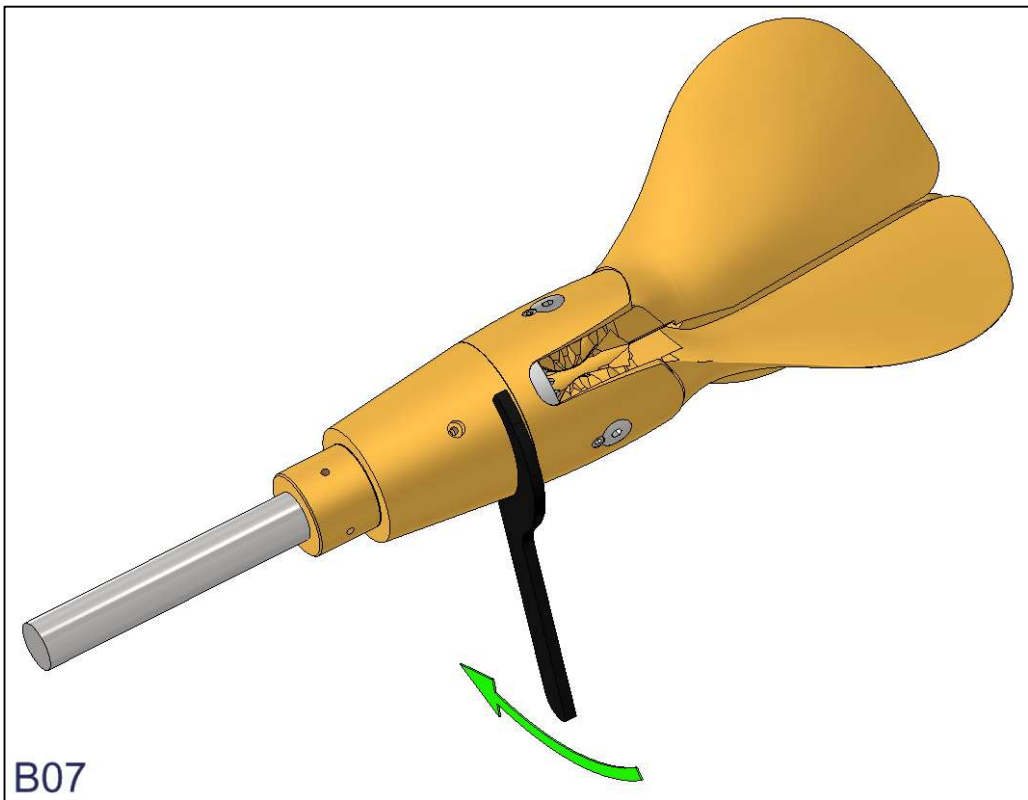
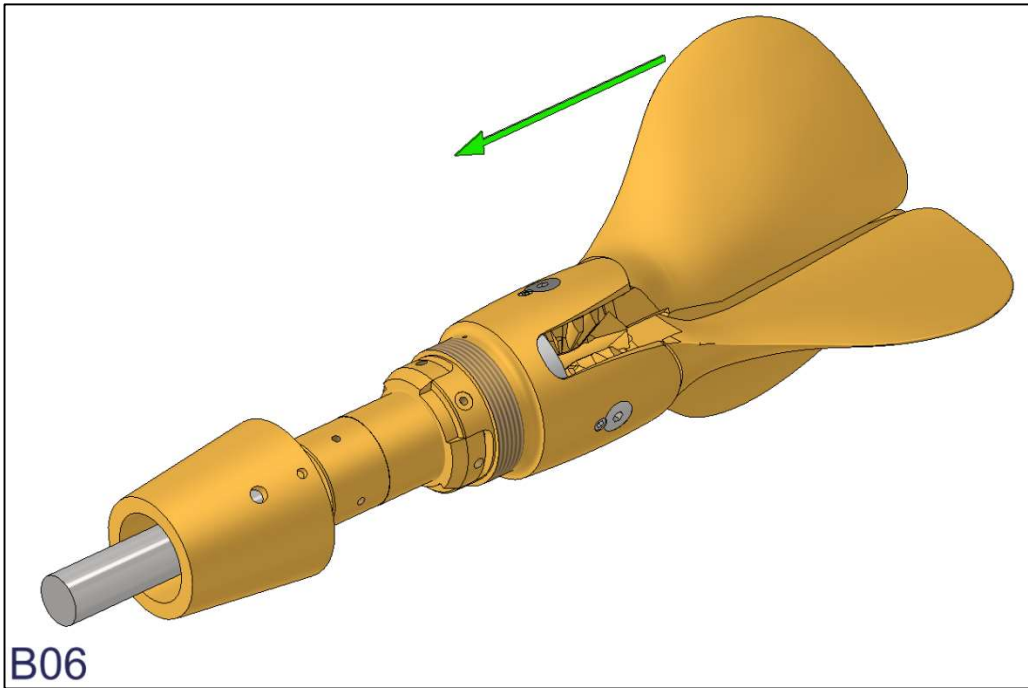

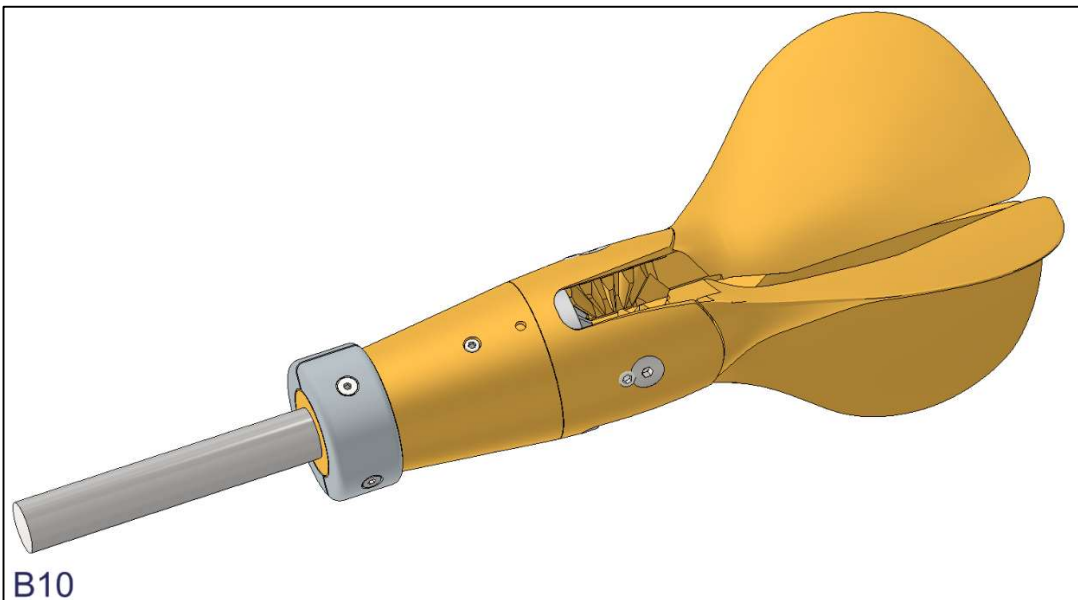
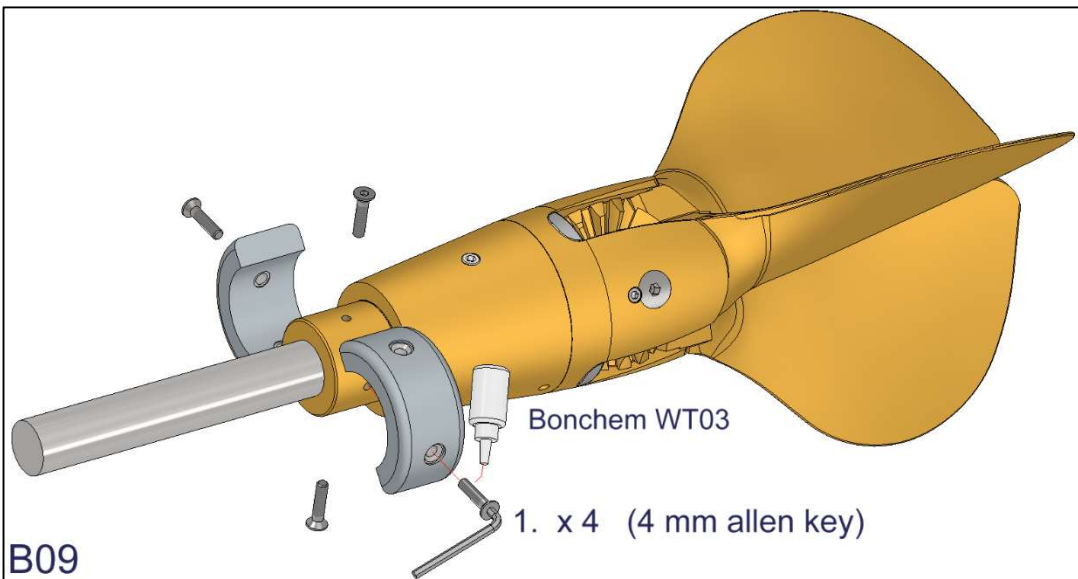
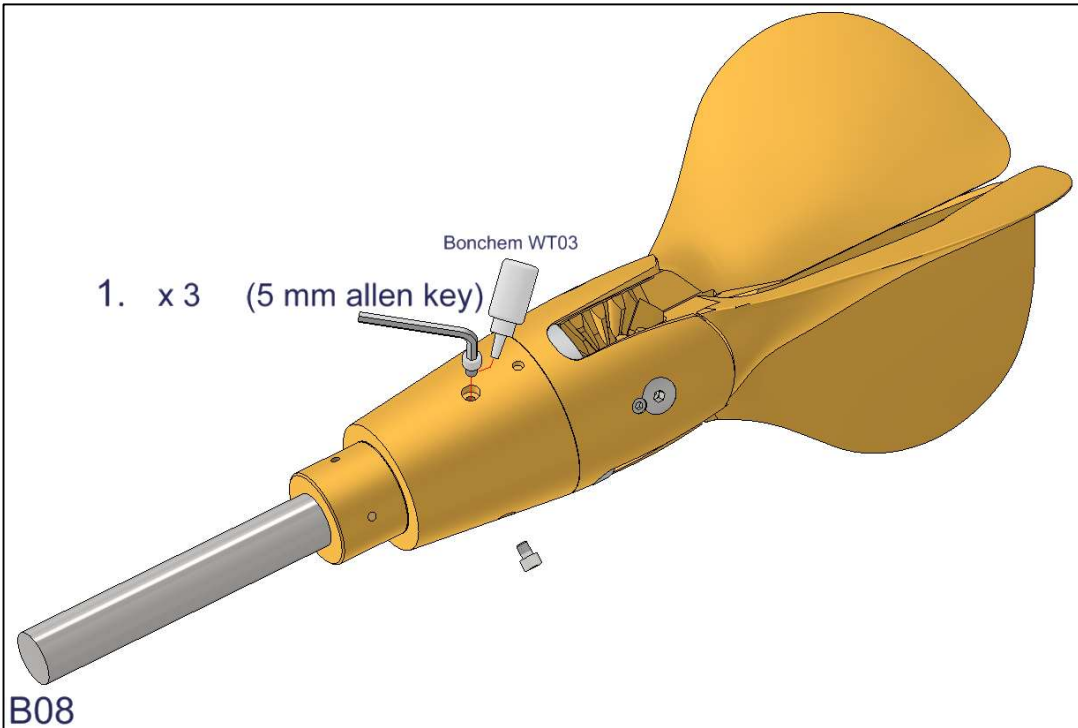

Exchange of "rubber blade stop" – (C)

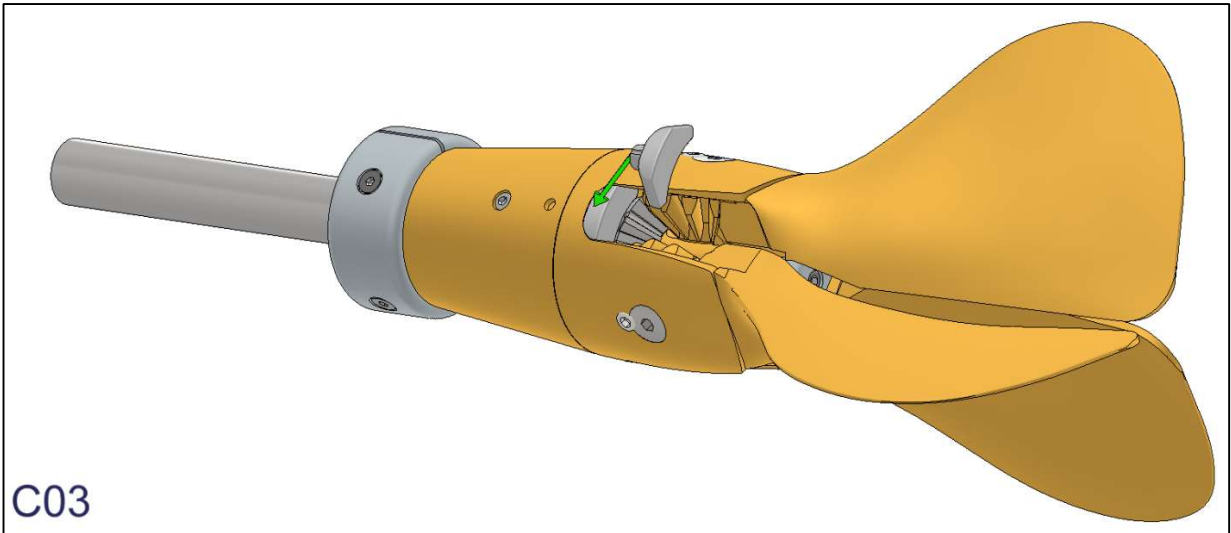
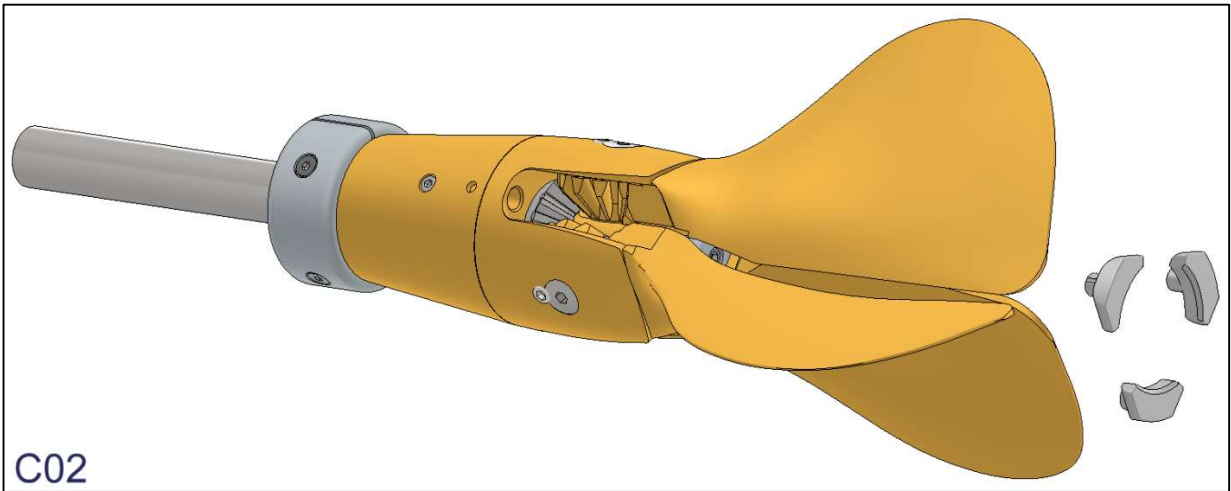
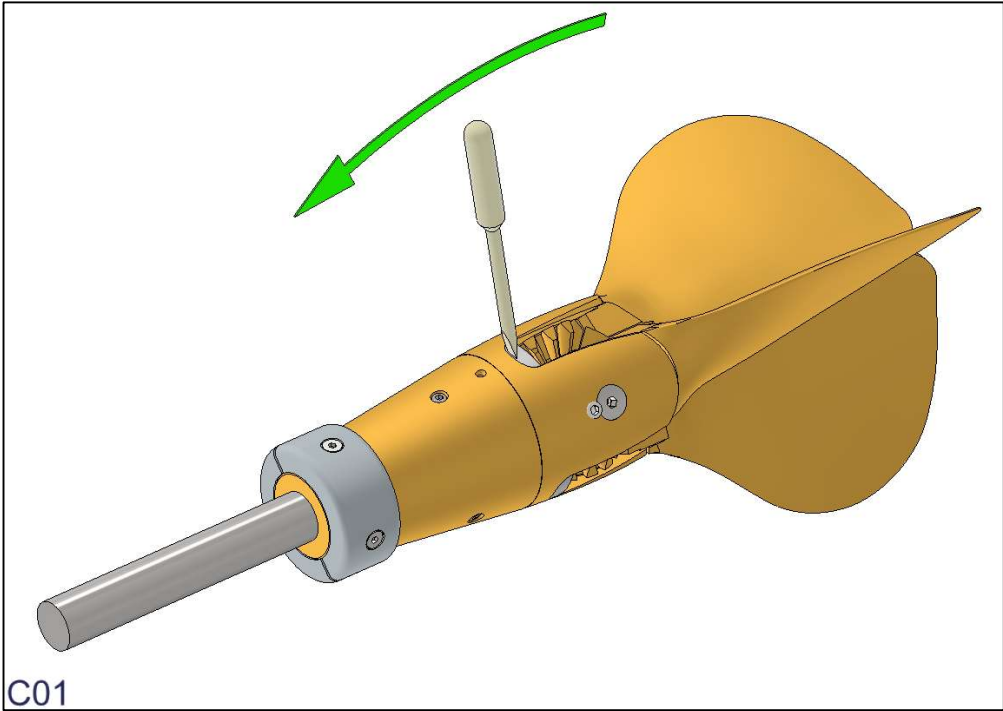

Exchange of “zinc anodes” – (D)

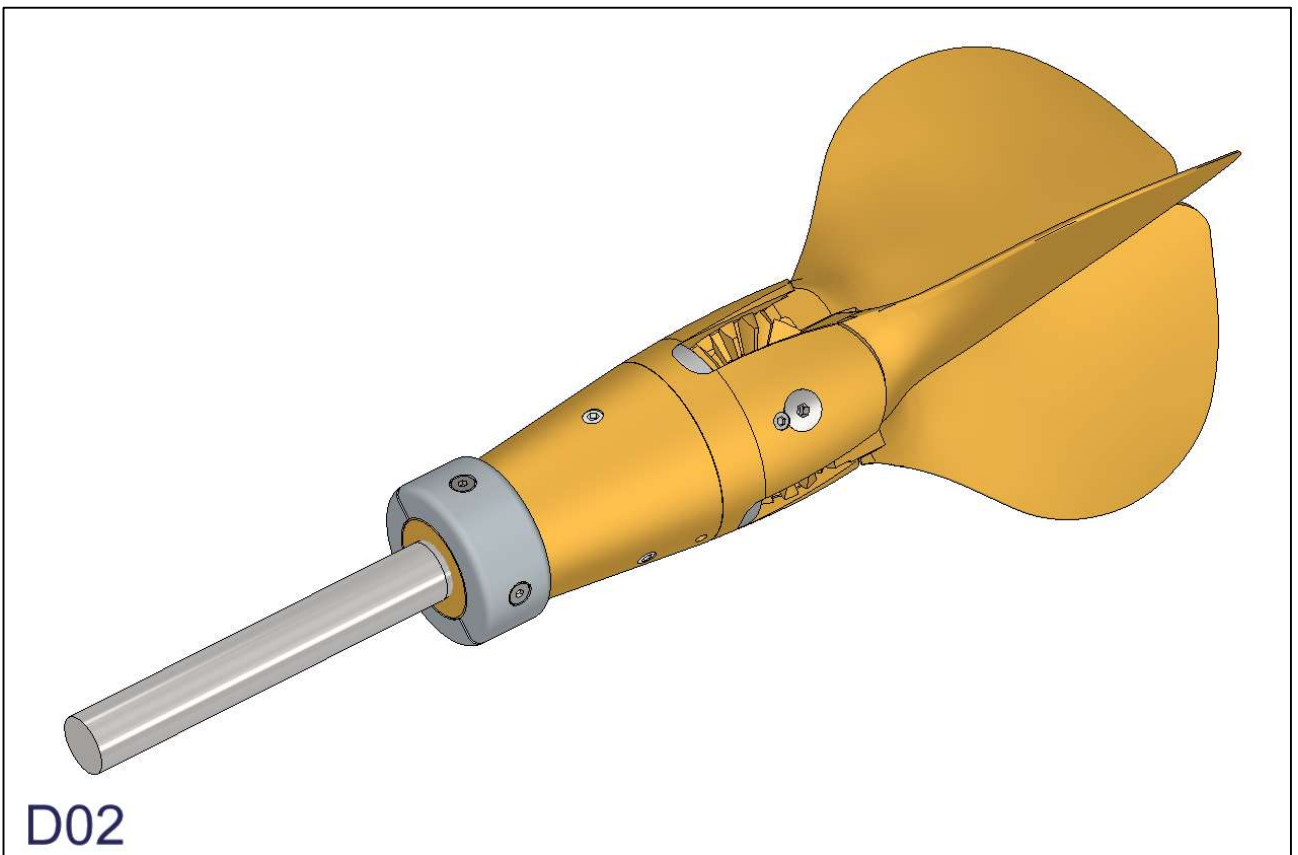
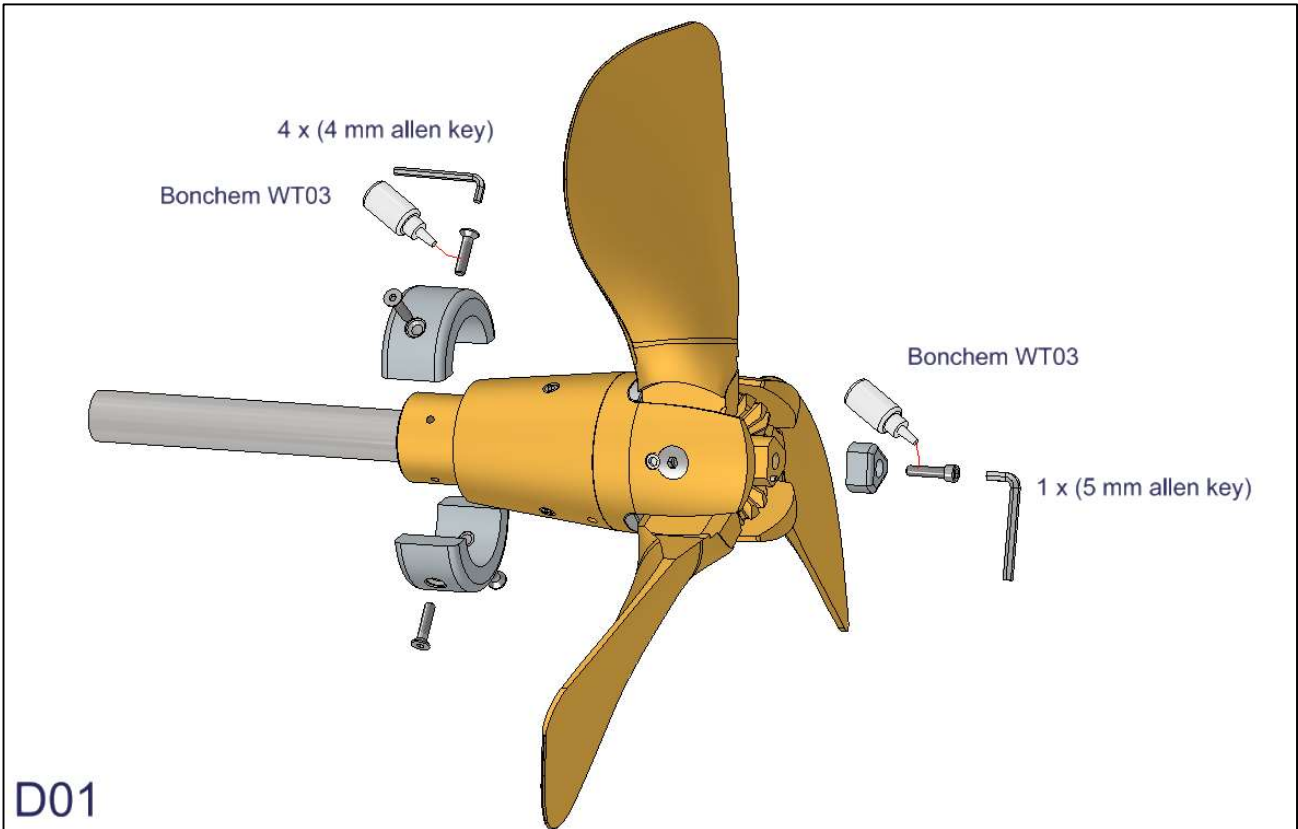

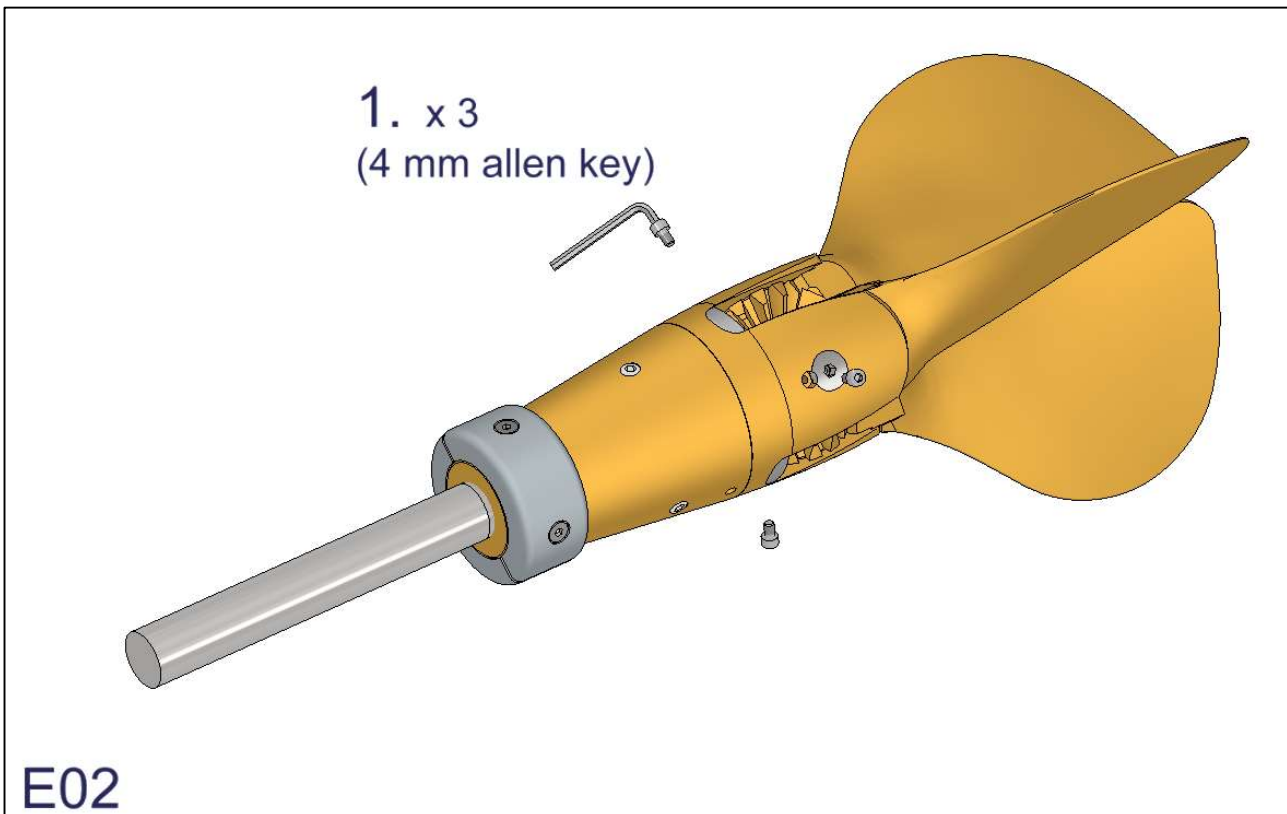
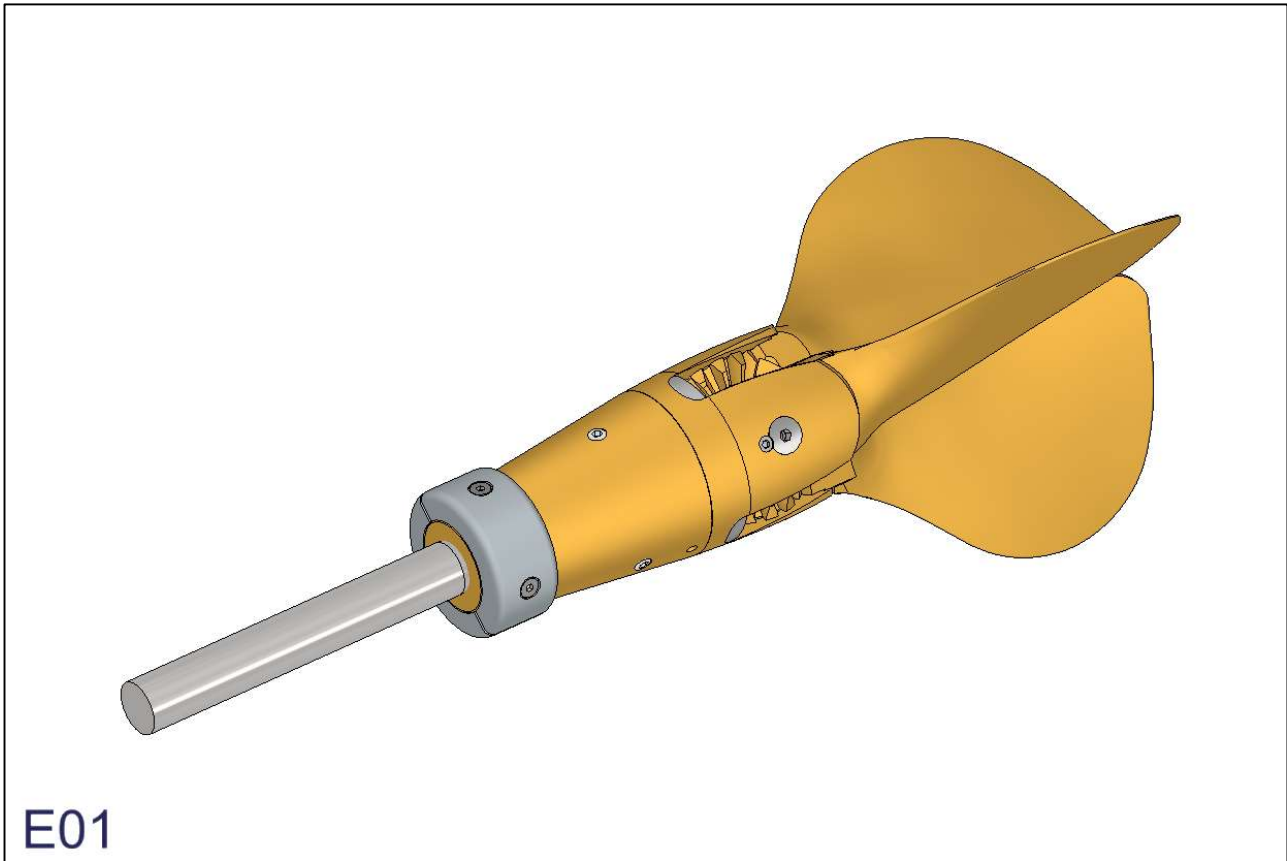

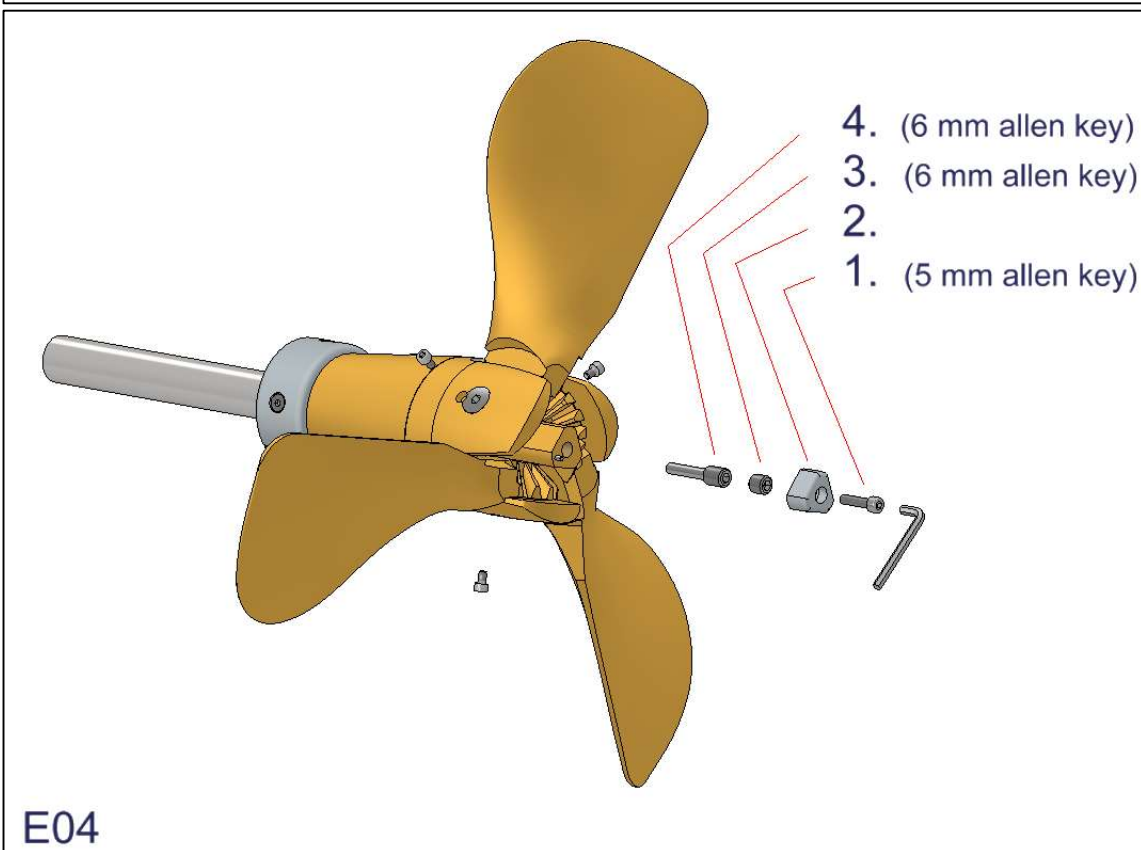
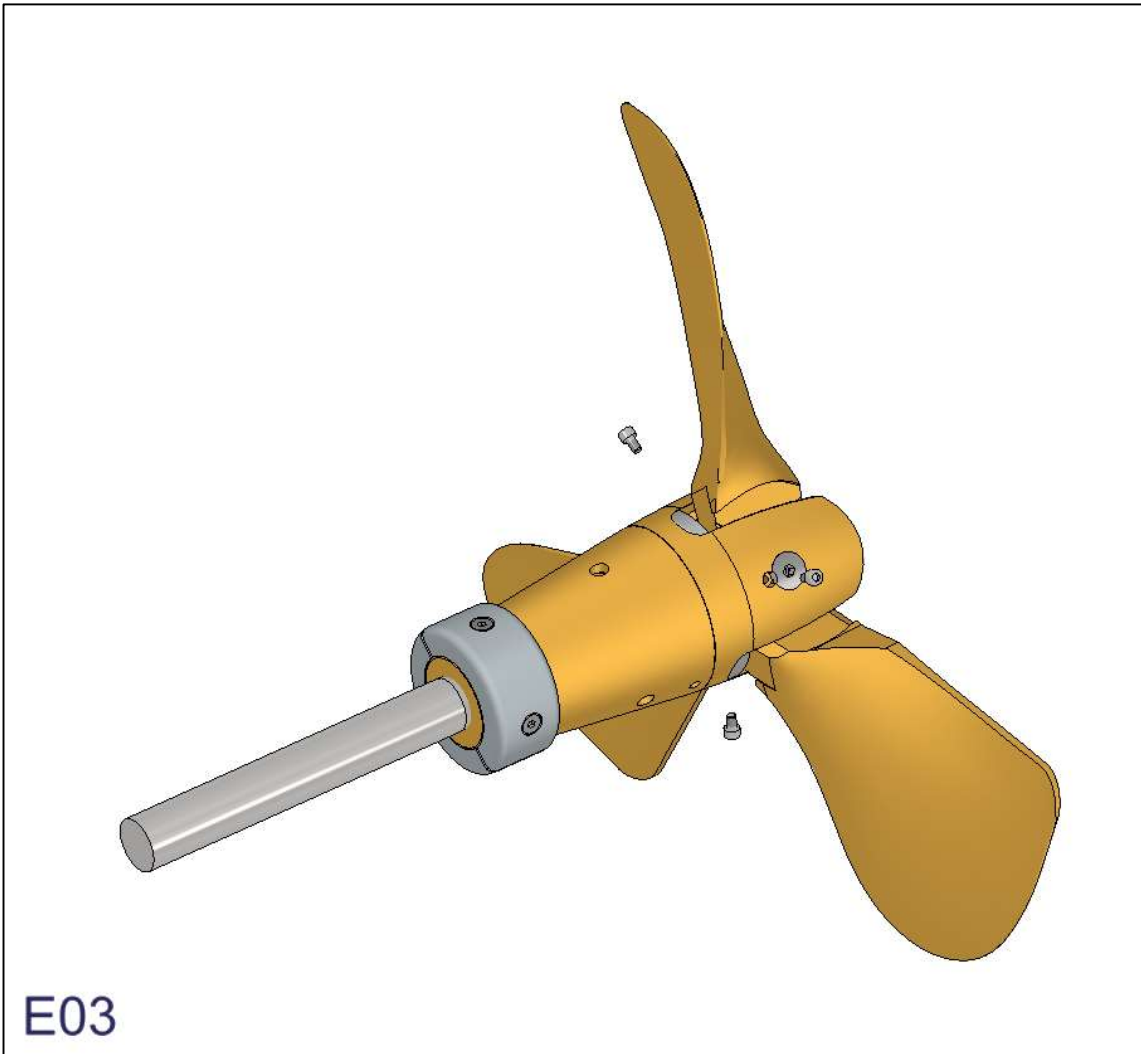

Cleaning of "Gearwheel" – (E)

Allen Key size 6 mm for size: 18" - 20".
Allen Key size 6 mm for size: 22" - 24" - 26".
Allen Key size 8 mm for size: 28" - 30".

1. x 3

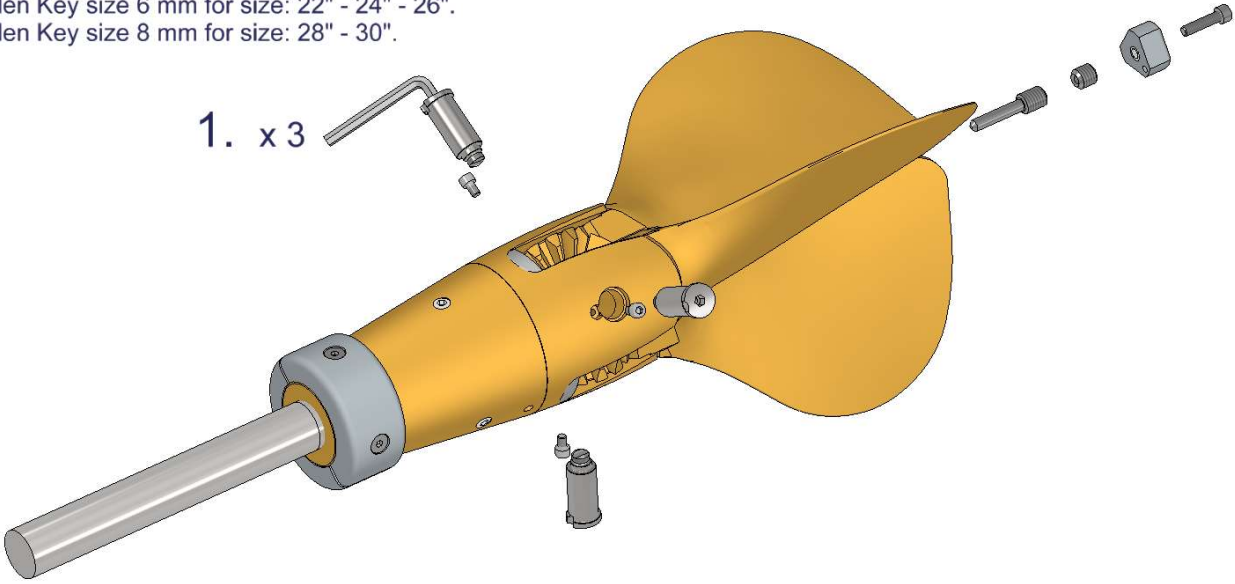

E05

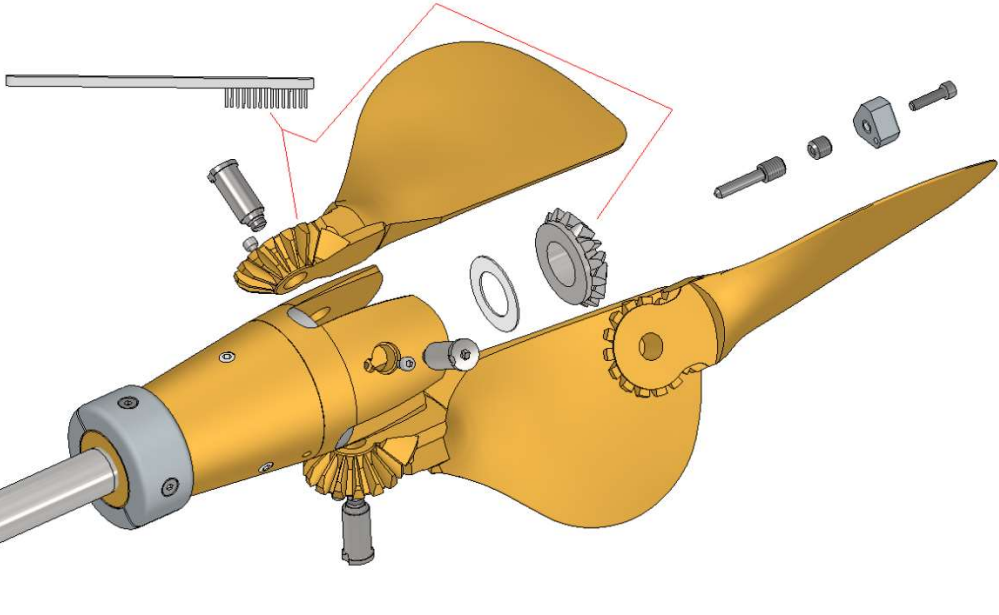

E06

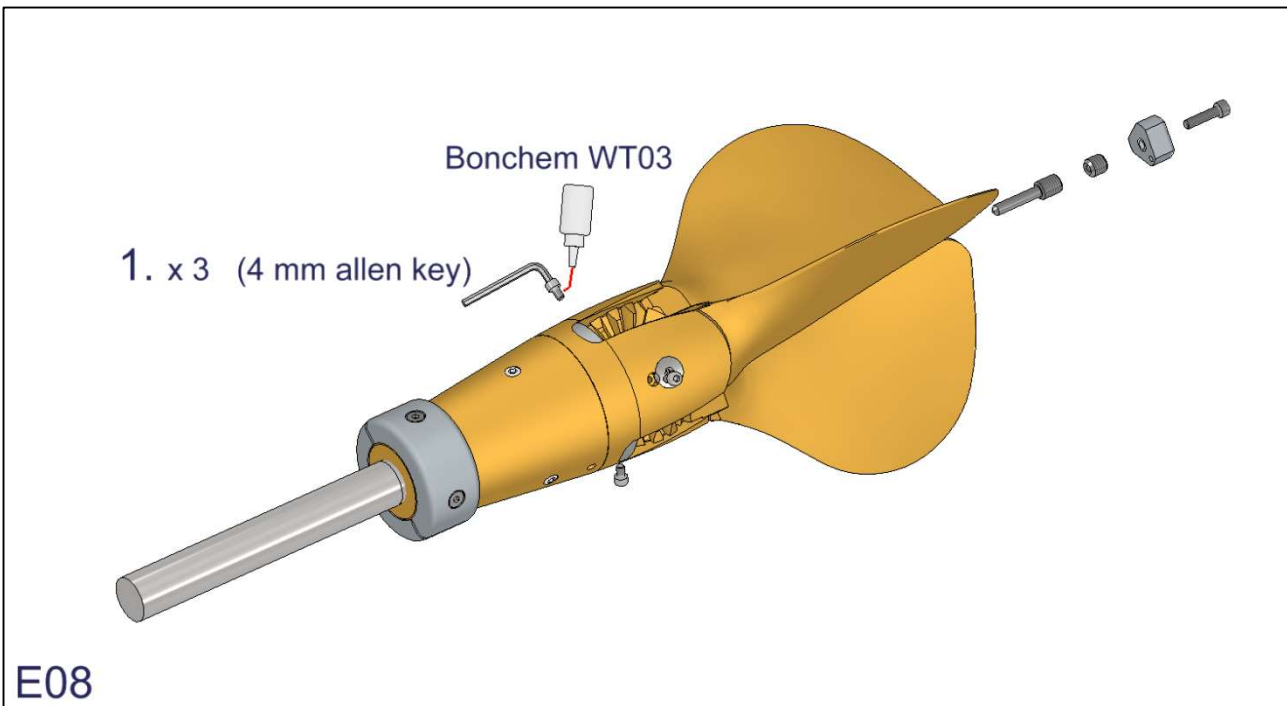
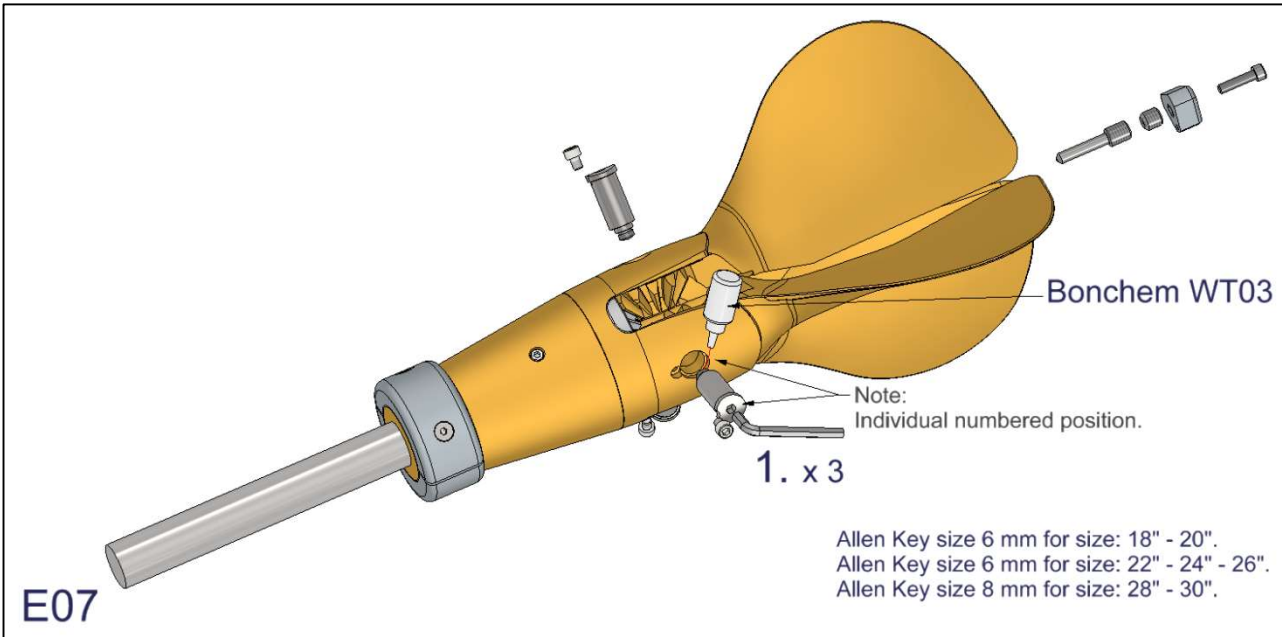

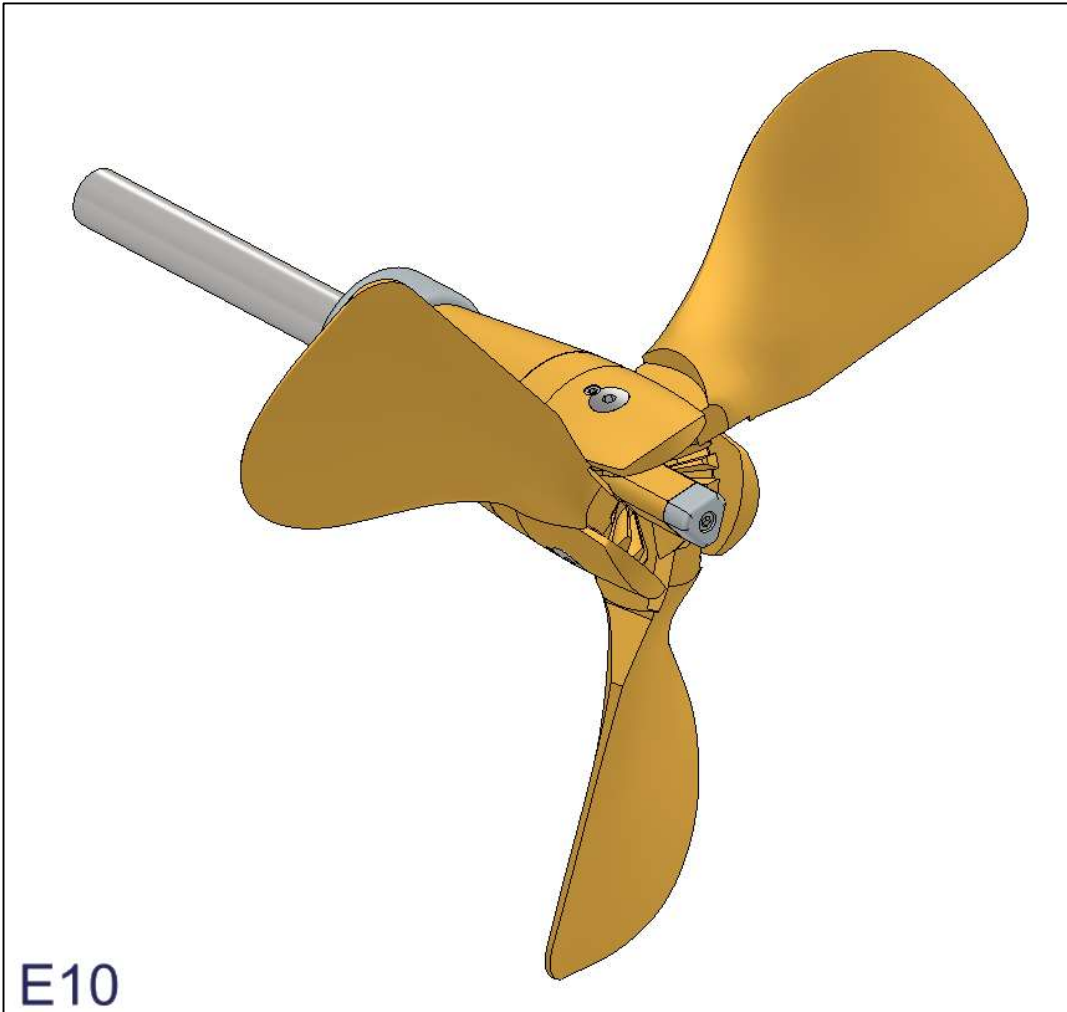
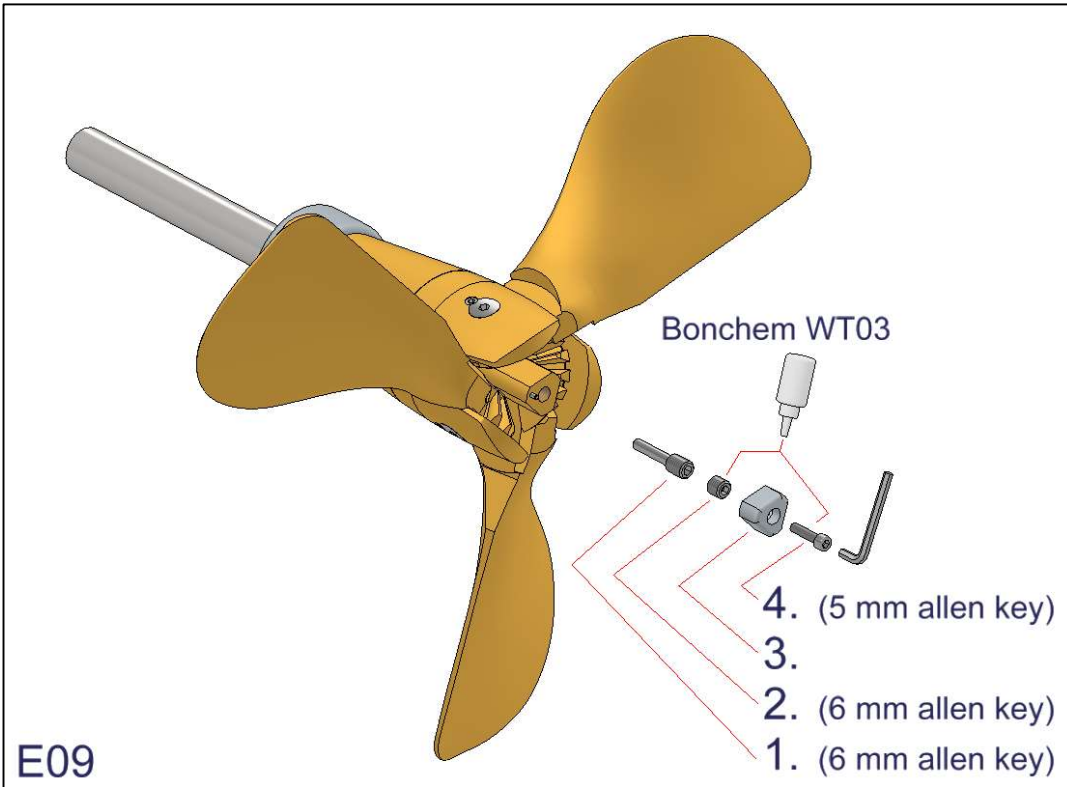

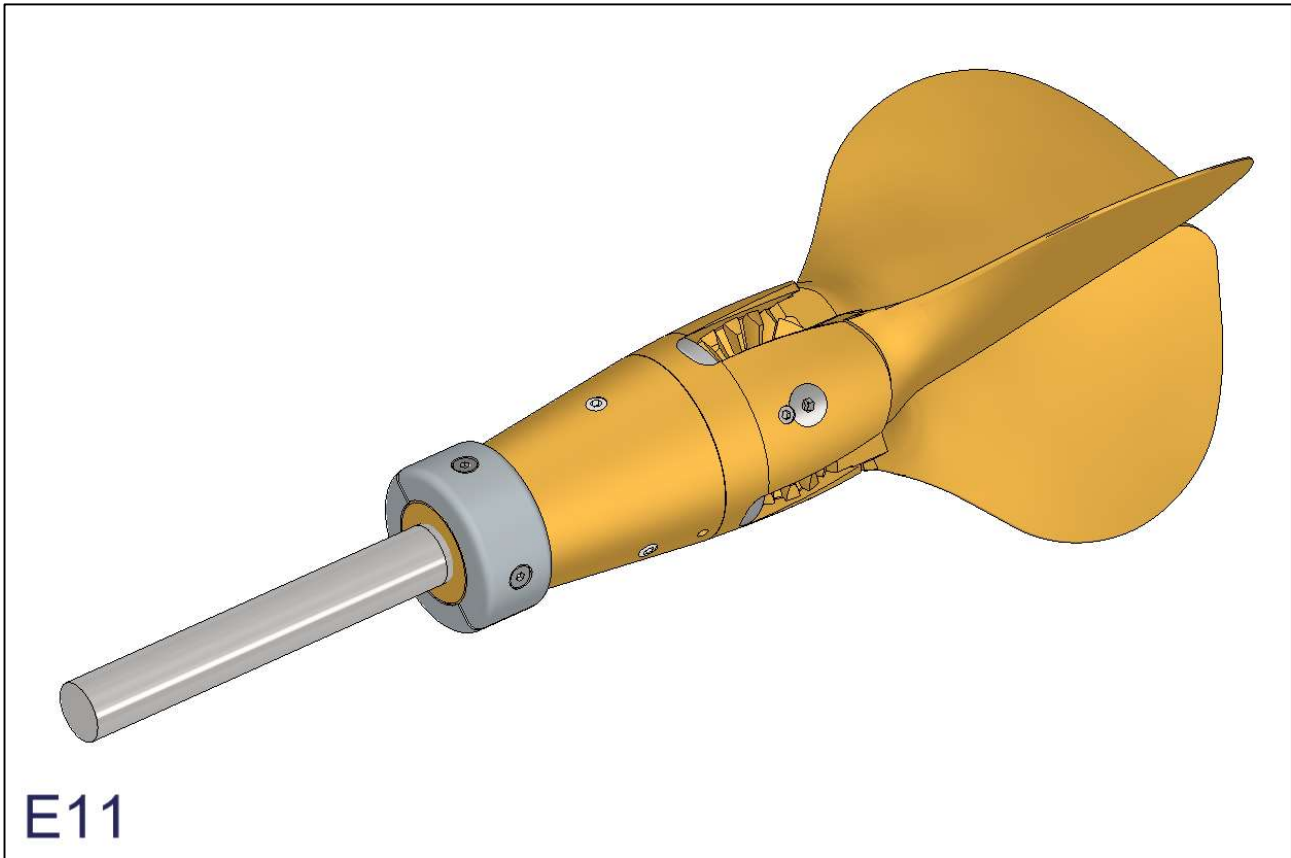

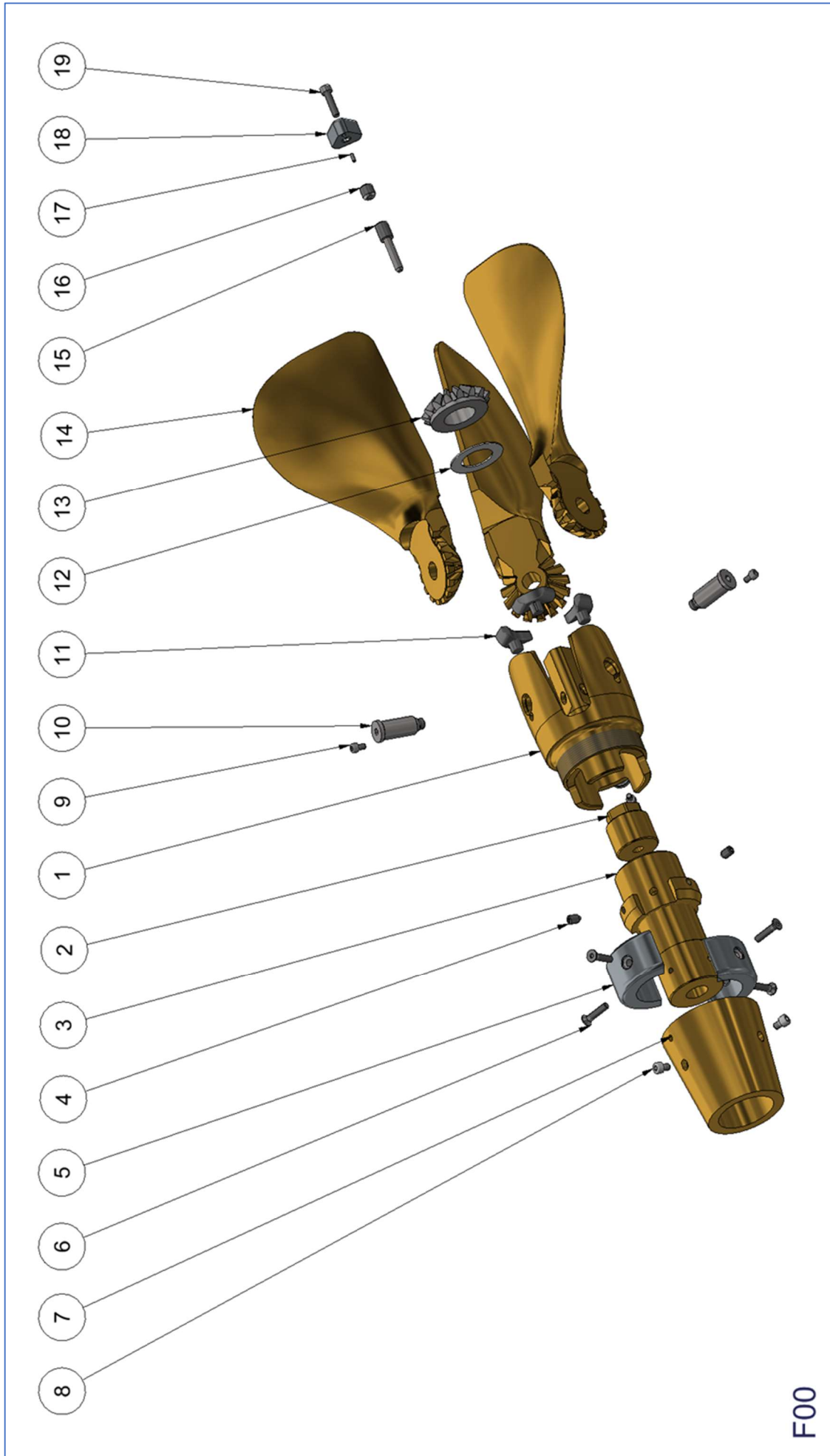

Service sets & Spare Parts List – (F)

Size: 18" – 20"

Service set 1407310000

ITEM	DK	GB	DE	STOCK NUMBER	QTY
18	Zinkanode - top	Zinc anode	Zink anode	1407300000	1
19	Skruer - Unbrako	Hex Socket Head Screw	Zylinderscherube mit Innensechskant	1407000625	1
-	Gevindsikring	Threadlocking	Schraubensicherung	1410000000	1
-	Unbrakonøgle - 5 mm	Allen key - 5 mm	Inbusschlüssel - 5 mm	1402100000	1

Service set 1473510000

ITEM	DK	GB	DE	STOCK NUMBER	QTY
11	Gummistopper	Rubber stop;	Gummianschläge	1407500000	3
18	Zinkanode - top	Zinc anode	Zink anode	1407300000	1
19	Skruer - Unbrako	Hex Socket Head Screw	Zylinderscherube mit Innensechskant	1407000625	1
-	Gevindsikring	Threadlocking	Schraubensicherung	1410000000	1
-	Unbrakonøgle - 5 mm	Allen key - 5 mm	Inbusschlüssel - 5 mm	1402100000	1

Service set 1407510000

ITEM	DK	GB	DE	STOCK NUMBER	QTY
11	Gummistopper	Rubber stop;	Gummianschläge	1407500000	3

Service set 1553000000

ITEM	DK	GB	DE	STOCK NUMBER	QTY
5	Zinkanode - ring	Zinc ring anode	Zinkring anode	1510550000	2
6	Undersænket skrue M6x22, A4	Flat Countersunk Head	Senkskrue	1179910622	4
-	Gevindsikring	Threadlocking	Schraubensicherung	1410000000	1
-	Unbrakonøgle - 4 mm	Allen key - 4 mm	Inbusschlüssel - 4 mm	1402000000	1

ITEM	DK	GB	DE	STOCK NUMBER	QTY
1	Navtop	Blade housing	Nabenoberteil	3500000095	1
2	Møtrik*	Nut*	Mütter*	---	1
3	Konusdel	Tapered part	Kegel	3400000095	1
4	Pinol skrue	Hex Socket Set Screw	Gewindestift	1401300000	3
5	Zinkanode - ring	Zinc ring anode	Zinkring anode	1510550000	2
6	Undersænket skrue M6x22, A4	Flat Countersunk Head	Senkskrue	1179910622	4
7	Nav kappe	Hub shell	Nabenschale	3300000095z	1
8	Skruer - cylindrisk hoved	Hex Socket Head	Cylinderskrue	1406800000	3
9	Skruer - cylindrisk hoved	Hex Socket Head	Cylinderskrue	1406900000	3
10	Aksel til propelblade	Blade pins	Führungsbolzen	1512000000	3
11	Gummistopper	Rubber stop;	Gummianschläge	1407500000	3
12	Afstandsskive	Spacer	Abstandshalter	1403000000	1
13	Tandhjul	Gear-wheel	Zahnrad	1407100000	1
14	Propelblade / 18" x 10" RH	Propeller blades / 18" x 10" RH	Propellerblätter / 18" x 10" RH	3118010001	3
14	Propelblade / 18" x 10" LH	Propeller blades / 18" x 10" LH	Propellerblätter / 18" x 10" LH	3118010002	3
14	Propelblade / 18" x 11" RH	Propeller blades / 18" x 11" RH	Propellerblätter / 18" x 11" RH	3118011001	3
14	Propelblade / 18" x 11" LH	Propeller blades / 18" x 11" LH	Propellerblätter / 18" x 11" LH	3118011002	3
14	Propelblade / 18" x 12" RH	Propeller blades / 18" x 12" RH	Propellerblätter / 18" x 12" RH	3118012001	3
14	Propelblade / 18" x 12" LH	Propeller blades / 18" x 12" LH	Propellerblätter / 18" x 12" LH	3118012002	3
14	Propelblade / 18" x 13" RH	Propeller blades / 18" x 13" RH	Propellerblätter / 18" x 13" RH	3118013001	3
14	Propelblade / 18" x 13" LH	Propeller blades / 18" x 13" LH	Propellerblätter / 18" x 13" LH	3118013002	3
14	Propelblade / 18" x 14" RH	Propeller blades / 18" x 14" RH	Propellerblätter / 18" x 14" RH	3118014001	3
14	Propelblade / 18" x 14" LH	Propeller blades / 18" x 14" LH	Propellerblätter / 18" x 14" LH	3118014002	3
14	Propelblade / 18" x 15" RH	Propeller blades / 18" x 15" RH	Propellerblätter / 18" x 15" RH	3118015001	3
14	Propelblade / 18" x 15" LH	Propeller blades / 18" x 15" LH	Propellerblätter / 18" x 15" LH	3118015002	3
14	Propelblade / 20" x 13" RH	Propeller blades / 20" x 13" RH	Propellerblätter / 20" x 13" RH	3120013001	3
14	Propelblade / 20" x 13" LH	Propeller blades / 20" x 13" LH	Propellerblätter / 20" x 13" LH	3120013002	3
14	Propelblade / 20" x 14" RH	Propeller blades / 20" x 14" RH	Propellerblätter / 20" x 14" RH	3120014001	3
14	Propelblade / 20" x 14" LH	Propeller blades / 20" x 14" LH	Propellerblätter / 20" x 14" LH	3120014002	3
14	Propelblade / 20" x 15" RH	Propeller blades / 20" x 15" RH	Propellerblätter / 20" x 15" RH	3120015001	3
14	Propelblade / 20" x 15" LH	Propeller blades / 20" x 15" LH	Propellerblätter / 20" x 15" LH	3120015002	3
14	Propelblade / 20" x 16" RH	Propeller blades / 20" x 16" RH	Propellerblätter / 20" x 16" RH	3120016001	3
14	Propelblade / 20" x 16" LH	Propeller blades / 20" x 16" LH	Propellerblätter / 20" x 16" LH	3120016002	3
15	Låsebolt for aksel	Locking pin	Haltebolzen	1453000000	1
16	Pinolskrue M12 / M6	Hex Socket set screw M12 / M6	Gewindestift M12 / M6	1400700000	1
17	Cylinderstift	Parallel Pin	Zylinderstift	1406600000	1
18	Zinkanode - top	Zinc anode	Zink anode	1407300000	1
19	Skruer - Unbrako	Hex Socket Head Screw	Zylinderscherube mit Innensechskant	1407000625	1

*: Møtrik – bestilles kunde specifik; Nut – ordered cuttom specific; Mütter – kundenspezifisch bestellt

Propeller: 18" - 20"			
Torque settings for Gori shaft nuts in Nm			
	Norm Thread		Torque
	Diameter	Pitch	
	mm	mm	Nm
5/8"-11 UNC	15.5	2.31	52
M16 x 2	15.7	2	53
M16 x 1.5	15.7	1.5	57
3/4"-10 UNC	18.7	2.54	81
M20 x 2.5	19.6	2.5	91
M20 x 2	19.7	2	96
M20 x 1.5	19.7	1.5	102
7/8"-9 UNC	21,8	2.82	118
M24 x 3	23.6	3	135
M24 x 2	23.7	2	144

Thread has to be greased
No grease on taper on shaft

Service sets & Spare Parts List – (F)

Size: 22" – 24" – 26"

Service set 1407410000

ITEM	DK	GB	DE	STOCK NUMBER	QTY
18	Zinkanode - top	Zinc anode	Zink anode	1407400000	1
19	Skrue - Unbrako	Hex Socket Head Screw	Zylinderscherube mit Innensechskant	1509120630	1
-	Gevindsikring	Threadlocking	Schraubensicherung	1410000000	1
-	Unbrakonøgle - 5 mm	Allen key - 5 mm	Inbusschlüssel - 5 mm	1402100000	1

Service set 1474610000

ITEM	DK	GB	DE	STOCK NUMBER	QTY
11	Gummistopper	Rubber stop;	Gummianschläge	1407600000	3
18	Zinkanode - top	Zinc anode	Zink anode	1407400000	1
19	Skrue - Unbrako	Hex Socket Head Screw	Zylinderscherube mit Innensechskant	1509120630	1
-	Gevindsikring	Threadlocking	Schraubensicherung	1410000000	1
-	Unbrakonøgle - 5 mm	Allen key - 5 mm	Inbusschlüssel - 5 mm	1402100000	1

Service set 1407610000

ITEM	DK	GB	DE	STOCK NUMBER	QTY
11	Gummistopper	Rubber stop;	Gummianschläge	1407600000	3

Service set 1554000000

ITEM	DK	GB	DE	STOCK NUMBER	QTY
5	Zinkanode - ring	Zinc ring anode	Zinkring anode	1510560000	2
6	Undersænket skrue M6x25, A4	Flat Countersunk Head	Senkskrue	1179910625	4
-	Gevindsikring	Threadlocking	Schraubensicherung	1410000000	1
-	Unbrakonøgle - 4 mm	Allen key - 4 mm	Inbusschlüssel - 4 mm	1402000000	1

ITEM	DK	GB	DE	STOCK NUMBER	QTY
1	Navtop	Blade housing	Nabenoberteil	3500000110	1
2	Møtrik*	Nut*	Mütter*	---	1
3	Konusdel	Tapered part	Kegel	3400000110	1
4	Pinol skrue	Hex Socket Set Screw	Gewindestift	1401300000	3
5	Zinkanode - ring	Zinc ring anode	Zinkring anode	1510560000	2
6	Undersænket skrue M6x25, A4	Flat Countersunk Head	Senkskrue	1179910625	4
7	Nav kappe	Hub shell	Nabenschale	3300000110z	1
8	Skrue - cylindrisk hoved	Hex Socket Head	Cylinderskrue	1406800000	3
9	Skrue - cylindrisk hoved	Hex Socket Head	Cylinderskrue	1406900000	3
10	Aksel til propelblade	Blade pins	Führungsbolzen	1513000000	3
11	Gummistopper	Rubber stop;	Gummianschläge	1407600000	3
12	Afstandsskive	Spacer	Abstandshalter	1403500000	1
13	Tandhjul	Gear-wheel	Zahnrad	1407200000	1
14	Propelblade / 22" x 13" RH	Propeller blades / 22" x 13" RH	Propellerblätter / 22" x 13" RH	3122013001	3
14	Propelblade / 22" x 13" LH	Propeller blades / 22" x 13" LH	Propellerblätter / 22" x 13" LH	3122013002	3
14	Propelblade / 22" x 14" RH	Propeller blades / 22" x 14" RH	Propellerblätter / 22" x 14" RH	3122014001	3
14	Propelblade / 22" x 14" LH	Propeller blades / 22" x 14" LH	Propellerblätter / 22" x 14" LH	3122014002	3
14	Propelblade / 22" x 15" RH	Propeller blades / 22" x 15" RH	Propellerblätter / 22" x 15" RH	3122015001	3
14	Propelblade / 22" x 15" LH	Propeller blades / 22" x 15" LH	Propellerblätter / 22" x 15" LH	3122015002	3
14	Propelblade / 22" x 16" RH	Propeller blades / 22" x 16" RH	Propellerblätter / 22" x 16" RH	3122016001	3
14	Propelblade / 22" x 16" LH	Propeller blades / 22" x 16" LH	Propellerblätter / 22" x 16" LH	3122016002	3
14	Propelblade / 22" x 17" RH	Propeller blades / 22" x 17" RH	Propellerblätter / 22" x 17" RH	3122017001	3
14	Propelblade / 22" x 17" LH	Propeller blades / 22" x 17" LH	Propellerblätter / 22" x 17" LH	3122017002	3
14	Propelblade / 24" x 15" RH	Propeller blades / 24" x 15" RH	Propellerblätter / 24" x 15" RH	3124015001	3
14	Propelblade / 24" x 15" LH	Propeller blades / 24" x 15" LH	Propellerblätter / 24" x 15" LH	3124015002	3
14	Propelblade / 24" x 16" RH	Propeller blades / 24" x 16" RH	Propellerblätter / 24" x 16" RH	3124016001	3
14	Propelblade / 24" x 16" LH	Propeller blades / 24" x 16" LH	Propellerblätter / 24" x 16" LH	3124016002	3
14	Propelblade / 24" x 17" RH	Propeller blades / 24" x 17" RH	Propellerblätter / 24" x 17" RH	3124017001	3
14	Propelblade / 24" x 17" LH	Propeller blades / 24" x 17" LH	Propellerblätter / 24" x 17" LH	3124017002	3
14	Propelblade / 24" x 18" RH	Propeller blades / 24" x 18" RH	Propellerblätter / 24" x 18" RH	3124018001	3
14	Propelblade / 24" x 18" LH	Propeller blades / 24" x 18" LH	Propellerblätter / 24" x 18" LH	3124018002	3
14	Propelblade / 24" x 19" RH	Propeller blades / 24" x 19" RH	Propellerblätter / 24" x 19" RH	3124019001	3
14	Propelblade / 24" x 19" LH	Propeller blades / 24" x 19" LH	Propellerblätter / 24" x 19" LH	3124019002	3

14	Propelblade / 26" x 16" RH	Propeller blades / 26" x 16" RH	Propellerblätter / 26" x 16" RH	3126016001	3
14	Propelblade / 26" x 16" LH	Propeller blades / 26" x 16" LH	Propellerblätter / 26" x 16" LH	3126016002	3
14	Propelblade / 26" x 17" RH	Propeller blades / 26" x 17" RH	Propellerblätter / 26" x 17" RH	3126017001	3
14	Propelblade / 26" x 17" LH	Propeller blades / 26" x 17" LH	Propellerblätter / 26" x 17" LH	3126017002	3
14	Propelblade / 26" x 18" RH	Propeller blades / 26" x 18" RH	Propellerblätter / 26" x 18" RH	3126018001	3
14	Propelblade / 26" x 18" LH	Propeller blades / 26" x 18" LH	Propellerblätter / 26" x 18" LH	3126018002	3
14	Propelblade / 26" x 19" RH	Propeller blades / 26" x 19" RH	Propellerblätter / 26" x 19" RH	3126019001	3
14	Propelblade / 26" x 19" LH	Propeller blades / 26" x 19" LH	Propellerblätter / 26" x 19" LH	3126019002	3
14	Propelblade / 26" x 20" RH	Propeller blades / 26" x 20" RH	Propellerblätter / 26" x 20" RH	3126020001	3
14	Propelblade / 26" x 20" LH	Propeller blades / 26" x 20" LH	Propellerblätter / 26" x 20" LH	3126020002	3
14	Propelblade / 26" x 21" RH	Propeller blades / 26" x 21" RH	Propellerblätter / 26" x 21" RH	3126021001	3
14	Propelblade / 26" x 21" LH	Propeller blades / 26" x 21" LH	Propellerblätter / 26" x 21" LH	3126021002	3
15	Låsebolt for aksel	Locking pin	Haltebolzen	1454000000	1
16	Pinolskrue M12 / M6	Hex Socket set screw M12 / M6	Gewindestift M12 / M6	1400600000	1
17	Cylinderstift	Parallel Pin	Zylinderstift	1406600000	1
18	Zinkanode - top	Zinc anode	Zink anode	1407400000	1
19	Skrue - Unbrako	Hex Socket Head Screw	Zylinderscherube mit Innensechskant	1509120630	1

*: Møtrik – bestilles kunde specifik; Nut – ordered cuttom specific; Mütter – kundenspezifisch bestellt

Propeller: 22" - 24" - 26"			
Torque settings for Gori shaft nuts in Nm			
	Norm Thread		Torque
	Diameter	Pitch	
	mm	mm	Nm
M20 x 2.5	19.6	2.5	91
M20 x 2	19.7	2	96
M20 x 1.5	19.7	1.5	102
7/8"-9 UNC	21,8	2.82	118
M24 x 3	23.6	3	135
M24 x 2	23.7	2	144
1"-8 UNC	25.0	3.18	151
1"-12 UNF	25.1	2.12	160
M27 x 2	26.7	2	198
1 1/8"-7 UNC	28,1	3,63	200
M30 x 2	29.7	2	245
1 1/4"-7 UNC	31,3	3,63	260
M33 x 2	32,7	2	305
M36 x 3	35.6	3	335
1 1/2"-6 UNC	37,6	4,23	335

Thread has to be greased
No grease on taper on shaft

Service sets & Spare Parts List – (F)

Size: 28" – 30".

Service set 1407451100

ITEM	DK	GB	DE	STOCK NUMBER	QTY
18	Zinkanode - top	Zinc anode	Zink anode	1407450100	1
19	Skruer - Unbrako	Hex Socket Head Screw	Zylinderskerube mit Innensechskant	1509120630	1
-	Gevindsikring	Threadlocking	Schraubensicherung	1410000000	1
-	Unbrakonøgle - 5 mm	Allen key - 5 mm	Inbusschlüssel - 5 mm	1402100000	1

Service set 1412610000

ITEM	DK	GB	DE	STOCK NUMBER	QTY
11	Gummistopper	Rubber stop;	Gummianschläge	1409700000	3
18	Zinkanode - top	Zinc anode	Zink anode	1407450100	1
19	Skruer - Unbrako	Hex Socket Head Screw	Zylinderskerube mit Innensechskant	1509120630	1
-	Gevindsikring	Threadlocking	Schraubensicherung	1410000000	1
-	Unbrakonøgle - 5 mm	Allen key - 5 mm	Inbusschlüssel - 5 mm	1402100000	1

Service set 1409710000

ITEM	DK	GB	DE	STOCK NUMBER	QTY
11	Gummistopper	Rubber stop;	Gummianschläge	1409700000	3

Service set 1555000000

ITEM	DK	GB	DE	STOCK NUMBER	QTY
5	Zinkanode - ring	Zinc ring anode	Zinkring anode	1549000000	2
6	Undersænket skrue M6x25, A4	Flat Countersunk Head	Senkskrue	1179910625	4
-	Gevindsikring	Threadlocking	Schraubensicherung	1410000000	1
-	Unbrakonøgle - 4 mm	Allen key - 4 mm	Inbusschlüssel - 4 mm	1402000000	1

ITEM	DK	GB	DE	STOCK NUMBER	QTY
1	Navtop	Blade housing	Nabenoberteil	3500000140	1
2	Møtrik*	Nut*	Mütter*	---	1
3	Konusdel	Tapered part	Kegel	3400000140	1
4	Pinol skrue	Hex Socket Set Screw	Gewindestift	1401300000	3
5	Zinkanode - ring	Zinc ring anode	Zinkring anode	1549000000	2
6	Undersænket skrue	Flat Countersunk Head	Senkskrue	1179910625	4
7	Nav kappe	Hub shell	Nabenschale	3300000140z	1
8	Cylinderskrue M8x10 A4	Hex Socket Head	Cylinderskrue	1509120810	3
9	Cylinderskrue DIN912 M6x8	Hex Socket Head	Cylinderskrue	1406800000	3
10	Aksel til propelblade	Blade pins	Führungsbolzen	1514000000	3
11	Gummistopper	Rubber stop;	Gummianschläge	1409700000	3
12	Afstandsskive	Spacer	Abstandshalter	1403910000	1
13	Tandhjul	Gear-wheel	Zahnrad	1440000000	1
14	Propelblade / 28" x 17" RH	Propeller blades / 28" x 17" RH	Propellerblätter / 28" x 17" RH	3128017001	3
14	Propelblade / 28" x 17" LH	Propeller blades / 28" x 17" LH	Propellerblätter / 28" x 17" LH	3128017002	3
14	Propelblade / 28" x 18" RH	Propeller blades / 28" x 18" RH	Propellerblätter / 28" x 18" RH	3128018001	3
14	Propelblade / 28" x 18" LH	Propeller blades / 28" x 18" LH	Propellerblätter / 28" x 18" LH	3128018002	3
14	Propelblade / 28" x 19" RH	Propeller blades / 28" x 19" RH	Propellerblätter / 28" x 19" RH	3128019001	3
14	Propelblade / 28" x 19" LH	Propeller blades / 28" x 19" LH	Propellerblätter / 28" x 19" LH	3128019002	3
14	Propelblade / 28" x 20" RH	Propeller blades / 28" x 20" RH	Propellerblätter / 28" x 20" RH	3128020001	3
14	Propelblade / 28" x 20" LH	Propeller blades / 28" x 20" LH	Propellerblätter / 28" x 20" LH	3128020002	3
14	Propelblade / 28" x 21" RH	Propeller blades / 28" x 21" RH	Propellerblätter / 28" x 21" RH	3128021001	3
14	Propelblade / 28" x 21" LH	Propeller blades / 28" x 21" LH	Propellerblätter / 28" x 21" LH	3128021002	3
14	Propelblade / 28" x 22" RH	Propeller blades / 28" x 22" RH	Propellerblätter / 28" x 22" RH	3128022001	3
14	Propelblade / 28" x 22" LH	Propeller blades / 28" x 22" LH	Propellerblätter / 28" x 22" LH	3128022002	3
14	Propelblade / 28" x 23" RH	Propeller blades / 28" x 23" RH	Propellerblätter / 28" x 23" RH	3128023001	3
14	Propelblade / 28" x 23" LH	Propeller blades / 28" x 23" LH	Propellerblätter / 28" x 23" LH	3128023002	3
14	Propelblade / 30" x 18" RH	Propeller blades / 30" x 18" RH	Propellerblätter / 30" x 18" RH	3130018001	3
14	Propelblade / 30" x 18" LH	Propeller blades / 30" x 18" LH	Propellerblätter / 30" x 18" LH	3130018002	3
14	Propelblade / 30" x 19" RH	Propeller blades / 30" x 19" RH	Propellerblätter / 30" x 19" RH	3130019001	3
14	Propelblade / 30" x 19" LH	Propeller blades / 30" x 19" LH	Propellerblätter / 30" x 19" LH	3130019002	3
14	Propelblade / 30" x 20" RH	Propeller blades / 30" x 20" RH	Propellerblätter / 30" x 20" RH	3130020001	3
14	Propelblade / 30" x 20" LH	Propeller blades / 30" x 20" LH	Propellerblätter / 30" x 20" LH	3130020002	3
14	Propelblade / 30" x 21" RH	Propeller blades / 30" x 21" RH	Propellerblätter / 30" x 21" RH	3130021001	3
14	Propelblade / 30" x 21" LH	Propeller blades / 30" x 21" LH	Propellerblätter / 30" x 21" LH	3130021002	3
14	Propelblade / 30" x 22" RH	Propeller blades / 30" x 22" RH	Propellerblätter / 30" x 22" RH	3130022001	3
14	Propelblade / 30" x 22" LH	Propeller blades / 30" x 22" LH	Propellerblätter / 30" x 22" LH	3130022002	3
14	Propelblade / 30" x 23" RH	Propeller blades / 30" x 23" RH	Propellerblätter / 30" x 23" RH	3130023001	3
14	Propelblade / 30" x 23" LH	Propeller blades / 30" x 23" LH	Propellerblätter / 30" x 23" LH	3130023002	3
14	Propelblade / 30" x 24" RH	Propeller blades / 30" x 24" RH	Propellerblätter / 30" x 24" RH	3130024001	3
14	Propelblade / 30" x 24" LH	Propeller blades / 30" x 24" LH	Propellerblätter / 30" x 24" LH	3130024002	3
15	Låsebolt for aksel	Locking pin	Haltebolzen	1454000000	1
16	Pinolskrue M12 / M6	Hex Socket set screw M12 / M6	Gewindestift M12 / M6	1400600000	1
17	Cylinderstift	Parallel Pin	Zylinderstift	1409600000	1
18	Zinkanode - top	Zinc anode	Zink anode	1407450100	1
19	Skruer - Unbrako	Hex Socket Head Screw	Zylinderskerube mit Innensechskant	1509120630	1

*: Møtrik – bestilles kunde specifik; Nut – ordered cuttom specific; Mütter – kundenspezifisch bestellt

Propeller: 28" - 30"			
Torque settings for Gori shaft nuts in Nm			
	Norm Thread		Torque
	Diameter	Pitch	
	mm	mm	Nm
M30 x 2	29.7	2	245
1 1/4"-7 UNC	31,3	3,63	260
M36 x 3	35.6	3	335
1 1/2"-6 UNC	37,6	4,23	335
M42 x 3	41,6	3	440
1 3/4"-5 UNC	43,9	5,08	450

Thread has to be greased
No grease on taper on shaft

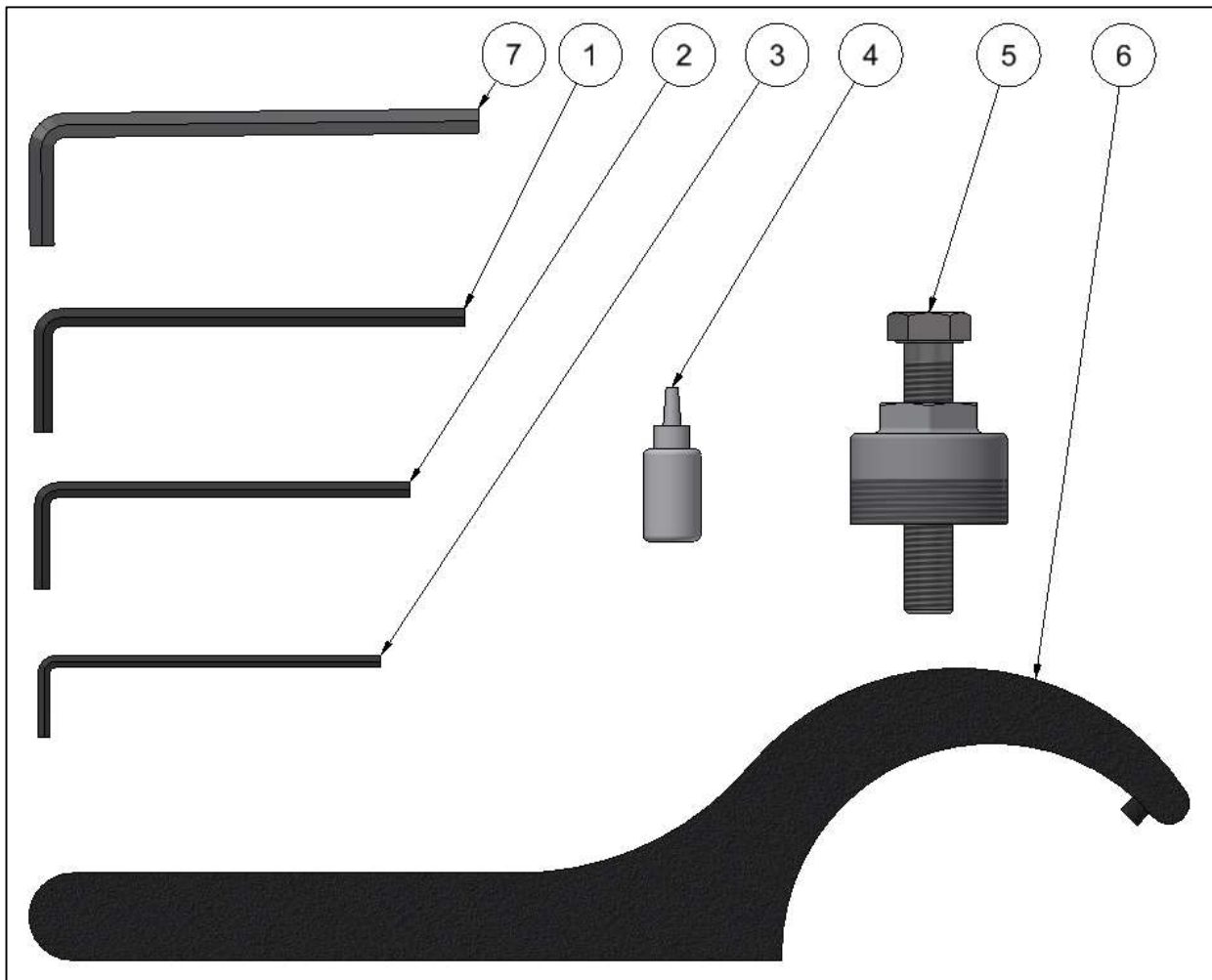

18" – 20"

ITEM	DK	GB	DE	STOCK NUMBER
1	Unbrakonøgle - 6 mm	Allen key - 6 mm	Inbusschlüssel - 6 mm	1402200000
2	Unbrakonøgle - 5 mm	Allen key - 5 mm	Inbusschlüssel - 5 mm	1402100000
3	Unbrakonøgle - 4 mm	Allen key - 4 mm	Inbusschlüssel - 4 mm	1402000000
4	Gevindsikring	Threadlocking	Schraubensicherung	1410000000
5	Aftrækker	Puller	Abzieher	1527000000
6	Hagenøgle	C-Spanner	Hagenschlüssel	1406700000

22" - 24" - 26"

ITEM	DK	GB	DE	STOCK NUMBER
1	Unbrakonøgle - 6 mm	Allen key - 6 mm	Inbusschlüssel - 6 mm	1402200000
2	Unbrakonøgle - 5 mm	Allen key - 5 mm	Inbusschlüssel - 5 mm	1402100000
3	Unbrakonøgle - 4 mm	Allen key - 4 mm	Inbusschlüssel - 4 mm	1402000000
4	Gevindsikring	Threadlocking	Schraubensicherung	1410000000
5	Aftrækker	Puller	Abzieher	1528000000
6	Hagenøgle	C-Spanner	Hagenschlüssel	1406300000

Supplied Tools – (G)

28" - 30"

ITEM	DK	GB	DE	STOCK NUMBER
7	Unbrakonøgle - 8 mm	Allen key - 8 mm	Inbusschlüssel - 8 mm	1409900000
1	Unbrakonøgle - 6 mm	Allen key - 6 mm	Inbusschlüssel - 6 mm	1402200000
2	Unbrakonøgle - 5 mm	Allen key - 5 mm	Inbusschlüssel - 5 mm	1402100000
3	Unbrakonøgle - 4 mm	Allen key - 4 mm	Inbusschlüssel - 4 mm	1402000000
4	Gevindsikring	Threadlocking	Schraubensicherung	1410000000
5	Aftrækker	Puller	Abzieher	1529000000
6	Hagenøgle	C-Spanner	Hagenschlüssel	1409800000

21082023

Gori propeller A/S

Fjordagervej 34-36

DK-6100 Haderslev

www.bsdk.com/gori-propeller/