



OMS

Ocean Marine Systems



THRUSTERS • **HYDRAULICS**



IMAGE: NAUTOR

Ocean Marine Systems

Established in 1998, OMS specialise in the custom design and manufacture of all products in-house. We use the latest materials and manufacturing techniques to provide the finest leading-edge solutions.

Our People

OMS supply bespoke engineering solutions to award-winning customers around the world, using a network of service agents working with a dedicated in-house project manager. OMS deliver projects on time, within budget and to the highest possible standard customers have come to expect.

Our Investment

At OMS we control as many aspects of the process as we can from customer order through to delivery, from our purpose-built factory and headquarters in Christchurch, UK. To achieve this, as a company we invest in both our people and machinery. Both are key to our success and together this supports our continued growth and development.

Bow & Stern Thrusters		Page 04
Tunnel Thrusters		Page 06
Technical Details		Page 07
Tunnel Thruster Hydraulic	Size Range: (-0250 to -1200)	Page 08
Tunnel Thruster Electric	Size Range: (-0250 to -1200)	Page 09
Vertical Retracting Thrusters		Page 10
Technical Details		Page 11
Vertical Retracting Thruster Hydraulic	Size Range: (-0250 to -1200)	Page 12
Vertical Retracting Thruster Electric	Size Range: (-0250 to -1200)	Page 13
Vertical Retracting & Rotating Thrusters		Page 14
Technical Details		Page 15
Vertical Retracting & Rotating Thruster Hydraulic	Size Range: (-0250 to -1200)	Page 16
Vertical Retracting & Rotating Thruster Electric	Size Range: (-0250 to -1200)	Page 17
Swing Thrusters		Page 18
Technical Details		Page 19
Vertical Swing Thruster Hydraulic	Size Range: (-0250 to -1200)	Page 20
Vertical Swing Thruster Electric	Size Range: (-0250 to -1200)	Page 21
Fixed Drive Leg		Page 22
Technical Details		Page 23
Fixed Drive Leg Electric	Size Range: (-0500 to -0750)	Page 24





Thruster Range

OMS offers a complete range of bow and stern thrusters. Our range caters for vessels from 20-150m with power ranging from 15kw to 800kw (20 - 1000 + hp) in both electric and hydraulic variants. As well as standard fixed tunnel units we also offer vertical retracting and swing variations.

OMS also have specific designs that integrate and work as part of dynamic positioning systems and also offer emergency propulsion with our rotating units.

A range of super-lightweight retracting thrusters have been developed specifically for new generation racer / cruiser class yachts. Fully custom solutions are available for commercial or specialist applications.

Having supplied units all over the world, OMS is leading the field in innovative design and construction.

Control & Power Options

OMS offers a range of Joy Sticks and control options that can be loose supplied or mounted on an OMS control panel for easy installation. Our standard OEM options are: bridge panels, wing panels & thruster control systems.

Our electric thrusters can be supplied with variable frequency drives (VFD) as part of the package in order to control variable power and smooth acceleration throughout the operation of the thruster.



Thruster Installation

Correct thruster installation is critical to ensure optimal performance.

Fixed tunnel installations should consider, minimum depth of immersion, proximity of the propellers to the end of the tunnel, tunnel edge radius, grill design, anode placement and more.

Retracting thruster installations should also consider, minimum depth of immersion, clearance of the deployed tunnel from the hull opening, proximity of other appendages and other factors.

OMS is always available to provide guidance on the most effective installation of our of thrusters.

Thruster Standard Paint Specification

OMS swing and vertical thrusters are supplied as standard with the following paint spec:

INBOARD PARTS:

Stainless steel, aluminium-bronze, acetal parts and fasteners will be untreated.

Aluminium parts will either be hard anodised or etch primed using an epoxy primer. A suitable gloss topcoat suitable for bilge areas will be applied.

UNDERWATER PARTS:

Stainless steel, aluminium-bronze, acetal parts and fasteners will be untreated.

Aluminium parts will either be hard anodised or etch primed and primed using an epoxy primer. DFT approximately 100 microns.

Service Network

OMS have an extensive Network of service agencies worldwide as well as supporting our products direct from factory.

SERVICE LOCATION



Location

Ocean Marine Systems Ltd

Ocean House, Aviation Business Park,
Bournemouth International Airport,
Christchurch, Dorset, BH23 6NW
United Kingdom

Contact us

Tel: +44 (0)1202 596630

Email: mail@oms.ltd

Opening Hours: Mon - Thurs 8 am to 5 pm / Fri 8 am to 12 pm

Web: oms.ltd

Warranty

OMS warrants its products in normal usage, to be free of defects in materials and workmanship of one years from the date of original purchase by the user, subject to conditions and materials.

Full warranty terms available on request.





IMAGE: FEADSHIP

T Series tunnel thrusters are compact and easy to fit units that can be supplied complete with steel, aluminium or composite tunnels, pre-drilled ready for installation.

The thruster hub units are protected by twin shaft seals on each propeller shaft, and a single shaft seal on the vertical input shaft. The tunnel thruster uses high torque spiral bevel gears and twin contra-rotating propellers to develop a high thrust to tunnel diameter ratio.

T Series thrusters are supplied complete with a mounting saddle, all gaskets / fasteners and a suitable interface for any hydraulic or electric motor. The motor is driven via a flexible coupling to reduce noise and vibration.

1. For hydraulic thrusters: a hydraulic fixed displacement gear motor or bent axis motor, suitable for open and closed loop applications.
2. For electric thrusters: a large range of standard motors with multiple voltages / frequencies are available. Also a range of permanent magnet motors that are compact and lightweight can be supplied for the same thrusters. Supplied flange or foot mounted for horizontal or vertical installation.
3. Aluminium bronze (AB2) cast hub with fill and drain ports.
4. Twin contra rotating aluminium bronze (AB2), four-blade matched specifically for the power requirements of the thruster.
5. A matched set of spiral bevel gears (two x crown wheels, one x pinion gear) are supported on super duplex stainless steel propeller and input shafts.
6. Hub unit protected by twin rotary shaft seals on propeller shafts, and single rotary shaft seal on the input shaft.
7. Flexible coupling between hub assembly and motor to reduce noise and vibration.
8. Tunnel saddle loose supplied to fit to exterior of tunnel and provide support for the thruster hub.
9. Motor table to support motor and house flexible coupling for hydraulic versions.
10. Factory test and inspection reports provided with all units.



HYDRAULIC MOTOR

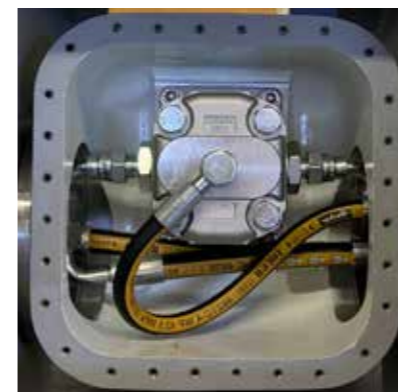

PERMANENT MAGNET MOTOR



STANDARD ELECTRIC MOTOR





Tunnel Thruster

Hydraulic

Size Range: (-0250 to -1200)

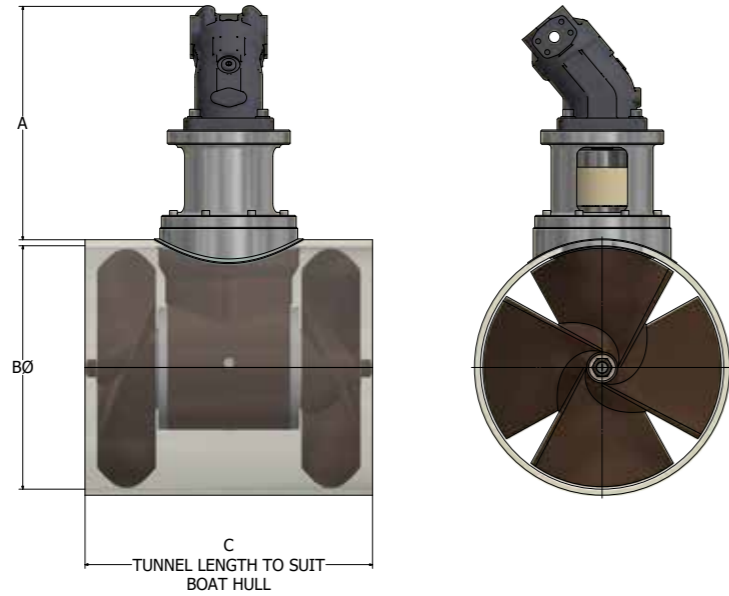

Model Number	Power (Max) (kw)	Thrust Developed (kg)	Prop Dia Nominal (mm)	A (mm)	(Ø) B (mm)	C (mm)
H-0250-T	25	300	255	255	254	300
H-0300-T	36	432	305	306	305	360
H-0400-T	63	756	406	408	406	480
H-0500-T	99	1188	508	476	508	560
H-0600-T	142	1704	610	543	610	674
H-0700-T	194	2328	711	634	711	786
H-0800-T	252	2772	813	725	813	899
H-1000-T	393	4323	1016	905	1016	1124
H-1200-T	565	6215	1219	859	1269	1300

Custom / non standard sizes available upon request.
x - Sizes for applications on request.



Tunnel Thruster

Electric

Size Range: (-0250 to -1200)

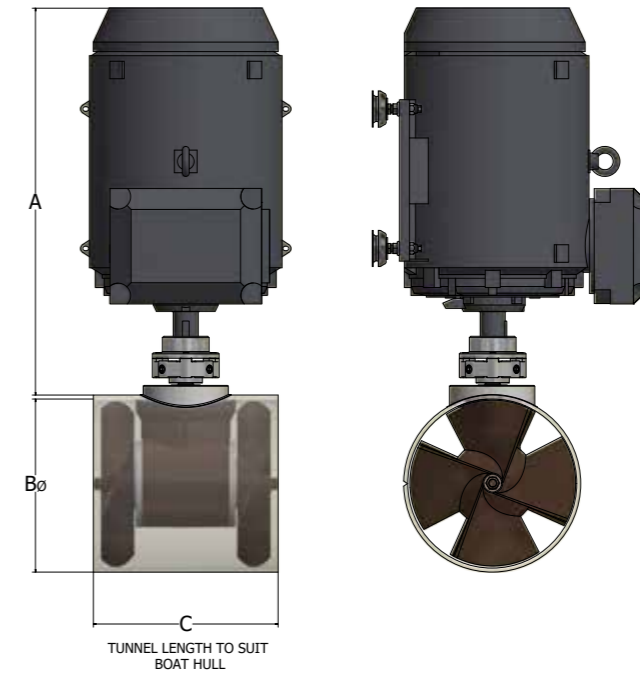

Model Number	Power (Max) (kw)	Thrust Developed (kg)	Prop Dia Nominal (mm)	A (mm)	(Ø) B (mm)	C (mm)
E-0250-T	25	300	255	569	245	300
E-0300-T	36	432	305	703	305	360
E-0400-T	63	756	406	956	406	480
E-0500-T	99	1188	508	1215	508	560
E-0600-T	142	1704	610	1413	610	674
E-0700-T	194	2328	711	1649	711	786
E-0800-T	252	2772	813	1881	813	899
E-1000-T	393	4323	1016	2350	1016	1124
E-1200-T	565	6215	1219	2645	1220	1300

Custom / non standard sizes available upon request.
Permanent magnet motor on request.
x - Sizes for applications on request.



Vertical Retracting Thrusters

OMS Thrusters



V Series vertical retracting thrusters benefit from the same in-hub technology as our T Series thrusters, whilst allowing the thruster to fully retract leaving a fair hull with minimal drag. This compact design uses a lead screw lift assembly with a reduction gear box to ensure that the thruster hub, when retracted, is held firmly in place.

The vertical thruster is also very useful where vessels have a deep V profile so the thruster is fitted higher providing a longer deployment stroke to clear the hull. They can also be fitted further forward or aft than a conventional tunnel thruster increasing the turning moment of the hull and therefore requiring less power input.

For added security all V Series thrusters can be manually raised or lowered in case of power failure. To ensure there is no environmental risk, the main drive motor, hydraulic hoses and electric cables are inside the vessel so are not open to sea water.

Technical Details

OMS Thrusters

1. For hydraulic thrusters: a fixed displacement gear motor or bent axis piston motor, suitable for open and closed loop applications. These motors benefit from good overall efficiency, excellent starting torque and a very compact design.
2. For electric thrusters: a permanent magnet motor. These motors benefit from extremely compact and robust structure, high efficiency and liquid cooled with plain water or water/glycol mixture.
3. Fabricated base plate / bearing assemblies with hole patterns, compliant to all classifications.
4. Ratio gearbox driving a trapezoidal threaded lead screw ensuring self-weight support of the thruster. Raise / lower limit switches and indicators. Twin lead screw used on 500 Series.
5. Aluminium bronze (AB2) or aluminium cast hub with fill and drain ports.
6. Twin contra rotating aluminium bronze (AB2), four-blade propellers matched specifically for the power requirements of the thruster.
7. A matched set of spiral bevel gears (two x crown wheels, one x pinion gear) are supported on super duplex stainless steel propeller and input shafts.
8. Hub unit protected by twin rotary shaft seals on propeller shafts, and single rotary shaft seal on the input shaft.
9. Flexible coupling between hub assembly and electric / hydraulic motor to reduce noise and vibration.
10. Factory test and inspection reports provided with all units.

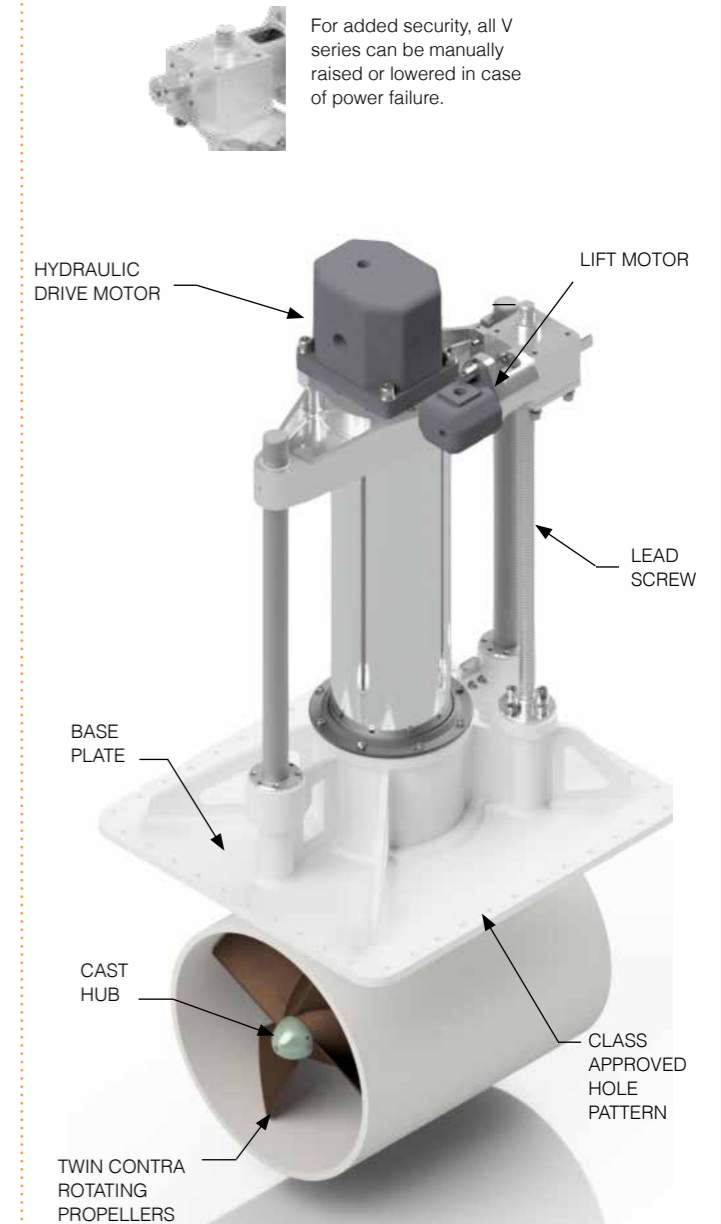

Thrusters





Vertical Retracting Thruster

Hydraulic

Size Range: (-0250 to -1200)

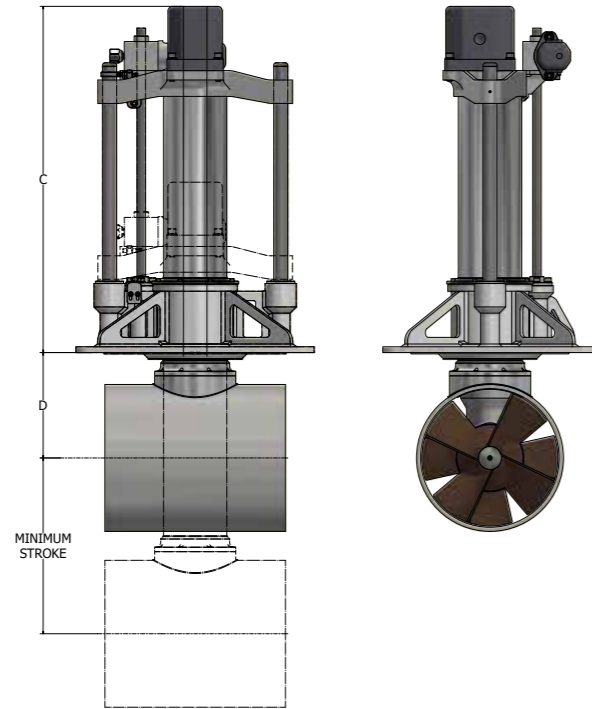
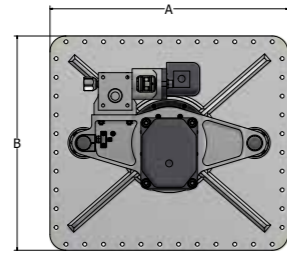

Model Number	Power (Max) (kw)	Thrust Developed (kg)	Prop Dia Nominal (mm)	Minimum Stroke (mm)	A (mm)	B (mm)	C (mm)	D (mm)
H-0250-V	25	300	255	275	460	360	760	193
H-0300-V	36	432	305	330	500	450	975	228
H-0400-V	63	756	406	440	600	620	1180	302
H-0500-V	99	1188	508	550	869	782	1299	396
H-0600-V	142	1704	610	660	1030	927	1540	469
H-0700-V	194	2328	711	770	1202	1082	1796	547
H-0800-V	252	2772	813	880	1374	1236	2052	625
H-1000-V	393	4323	1016	1100	1500	1400	2352	670
H-1200-V	565	6215	1219	1320	1500	1500	2701	781

Custom / non standard sizes available upon request.
x - Sizes for applications on request.



Vertical Retracting Thruster

Electric

Size Range: (-0250 to -1200)

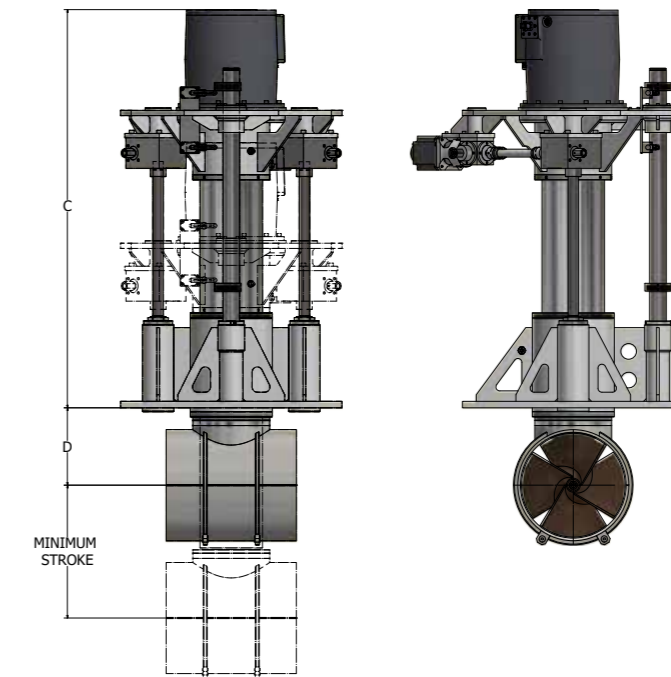
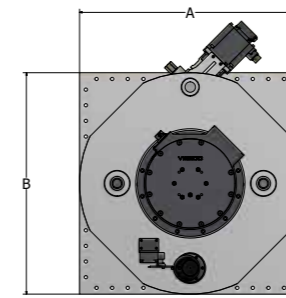

Model Number	Power (Max) (kw)	Thrust Developed (kg)	Prop Dia Nominal (mm)	Minimum Stroke (mm)	A (mm)	B (mm)	C (mm)	D (mm)
E-0250-V	25	300	255	275	355	355	701	181
E-0300-V	36	432	305	330	450	450	930	225
E-0400-V	63	756	406	440	598	598	1181	305
E-0500-V	99	1188	508	550	745	745	1334	375
E-0600-V	142	1704	610	660	884	884	1744	451
E-0700-V	194	2328	711	770	1031	1031	2035	526
E-0800-V	252	2772	813	880	1178	1178	2326	601
E-1000-V	393	4323	1016	1100	1473	1473	2907	750
E-1200-V	565	6215	1219	1320	x	x	x	x

Custom / non standard sizes available upon request.
x - Sizes for applications on request.



Vertical Retracting & Rotating Thrusters

OMS Thrusters



IMAGE: BALTIC YACHTS

Our vertical 360° rotating thrusters benefit from the same in-hub technology as the fixed tunnel thruster, whilst allowing the thruster to fully retract leaving a fair hull with minimal drag. This type of thruster has a very small footprint so is ideally suited to installation in aft or fore lockers where space is at a premium.

The vertical rotating thruster is also very useful where vessels have a deep V profile so the thruster is fitted higher providing a longer deployment stroke to clear the hull. They can also be fitted further forward or aft than a conventional tunnel thrusters increasing the turning moment of the hull and therefore requiring less power input.

This type of thruster uses a vertical lead screw and guide rods to raise and lower the unit via a motor. As with the swing thruster, all motors and hoses are concealed within the vessel so are not in direct contact with sea water. OMS has worked with a number of boat builders to optimise the range offered. The rotate mechanism allows you to position the pod and provide 360 degrees of thrust.

The OMS rotating thruster has also been installed and used as emergency propulsion.

Technical Details

OMS Thrusters

1. For hydraulic thrusters: a fixed displacement gear motor or bent axis piston motor, suitable for open and closed loop applications. These motors benefit from good overall efficiency, excellent starting torque and a very compact design.
2. For electric thrusters: a Permanent Magnet motor. These motors benefit from extremely compact and robust structure, high efficiency and liquid cooled with plain water or water/glycol mixture.
3. Fabricated base plate / bearing assemblies with hole patterns compliant to all classifications.
4. Ratio gearbox driving a trapezoidal threaded lead screw ensuring self-weight support of the thruster. Raise / lower limit switches and indicators.
5. Aluminium bronze (AB2) or aluminium cast hub with fill and drain ports.
6. Twin contra rotating aluminium bronze (AB2), four-blade propellers matched specifically for the power requirements of the thruster.
7. A matched set of spiral bevel gears (two x crown wheels, one x pinion gear) are supported on super duplex stainless steel propeller and input shafts.
8. Hub unit protected by twin rotary shaft seals on propeller shafts, and single rotary shaft seal on the input shaft.
9. Flexible coupling between hub assembly and electric motor to reduce noise and vibration.
10. Factory test and inspection reports provided with all units.

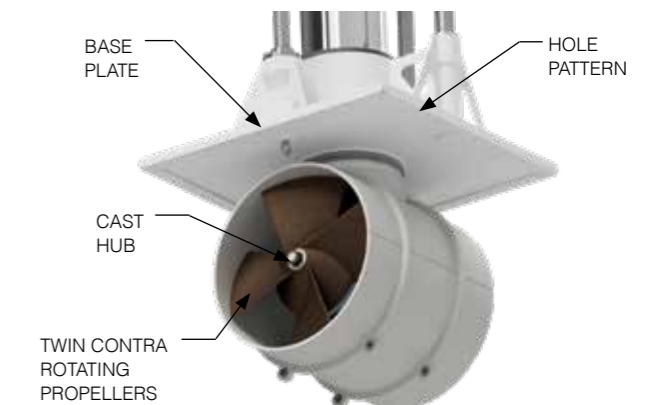
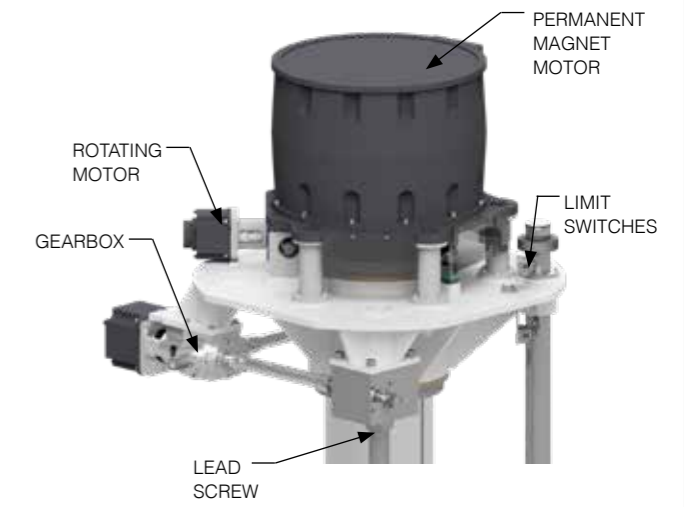

For added security, all V series can be manually raised or lowered in case of power failure.





Vertical Retracting & Rotating Thruster

Hydraulic

Size Range: (-0250 to -1200)

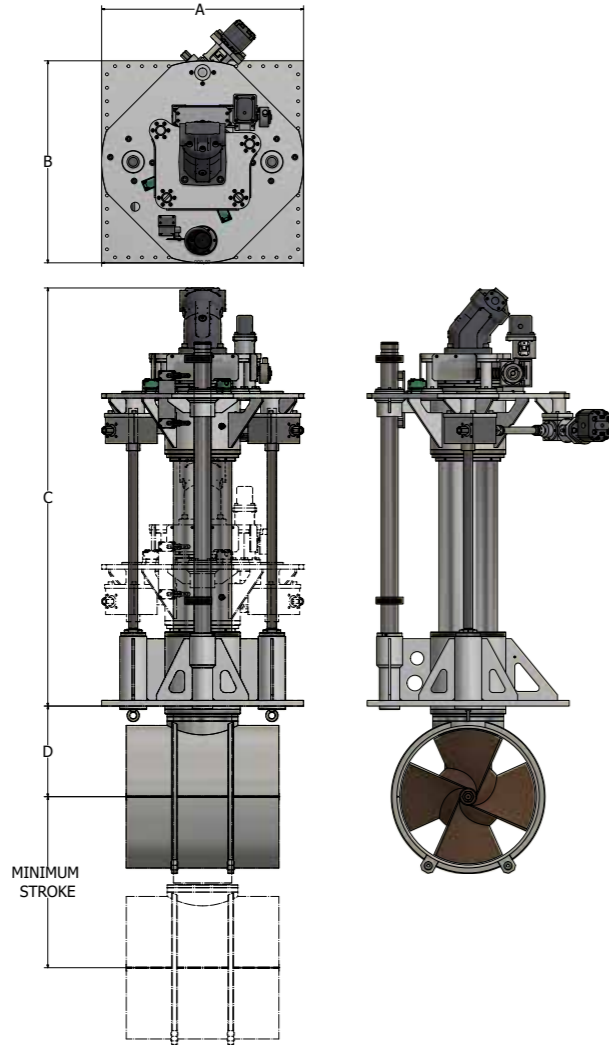

Model Number	Power (Max) (kw)	Thrust Developed (kg)	Prop Dia Nominal (mm)	Minimum Stroke (mm)	A (mm)	B (mm)	C (mm)	D (mm)
H-0250-V-R	25	300	255	275	355	355	701	181
H-0300-V-R	36	432	305	330	450	450	930	225
H-0400-V-R	63	756	406	440	598	598	1181	305
H-0500-V-R	99	1188	508	550	745	745	1334	375
H-0600-V-R	142	1704	610	660	884	884	1744	451
H-0700-V-R	194	2328	711	770	1031	1031	2035	526
H-0800-V-R	252	2772	813	880	1178	1178	2326	601
H-1000-V-R	393	4323	1016	1100	1473	1473	2907	750
H-1200-V-R	565	6215	1219	1320	1500	1500	3370	761

Custom / non standard sizes available upon request.
x - Sizes for applications on request.



Vertical Retracting & Rotating Thruster

Electric

Size Range: (-0250 to -1200)

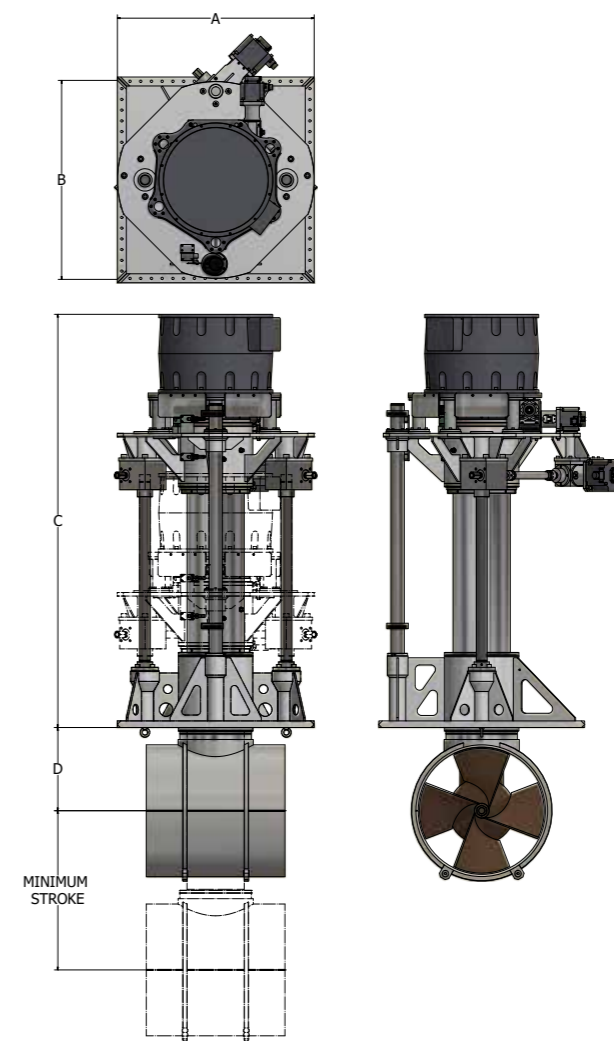

Model Number	Power (Max) (kw)	Thrust Developed (kg)	Prop Dia Nominal (mm)	Minimum Stroke (mm)	A (mm)	B (mm)	C (mm)	D (mm)
E-0250-V-R	25	300	255	275	355	355	701	181
E-0300-V-R	36	432	305	330	750	750	1508	230
E-0400-V-R	63	756	406	440	850	850	1666	297
E-0500-V-R	99	1188	508	550	850	850	1860	354
E-0600-V-R	142	1704	610	660	1020	1020	1910	404
E-0700-V-R	194	2328	711	770	1100	1150	2190	465
E-0800-V-R	252	2772	813	880	1200	1200	2400	532
E-1000-V-R	393	4323	1016	1100	1473	1473	2907	750
E-1200-V-R	565	6215	1219	1320	1500	1500	3359	763

Custom / non standard sizes available upon request.
x - Sizes for applications on request.



Swing Thrusters

OMS Thrusters

Technical Details

OMS Thrusters



IMAGE: BALTIC YACHTS

The swing thruster benefits from the same in-hub technology as the fixed tunnel thruster, whilst allowing the thruster to fully retract leaving a fair hull with minimal drag. These types of thrusters are usually used in applications where they are positioned within the accommodation area of a vessel. The low profile and compact design allows them to be easily fitted below floor bearers or in low level lockers, under beds or among other locations.

This compact design uses a lead screw lift assembly with a reduction gear box to ensure that the thruster hub, when retracted is held firmly in place and cannot move. In addition, OMS swing thrusters feature a locking pin which adds additional security when locking the leg in the raised position. The main drive motor and hydraulic hoses or cables are fully enclosed within the upper leg assembly so are not open to sea water. OMS have worked with a number of boat builders to optimise the range offered.

1. For hydraulic thrusters: a fixed displacement bent axis axial piston hydraulic motor, suitable for open and closed loop applications.
2. For electric thrusters: a permanent magnet motor. These motors benefit from extremely compact and robust structure, high efficiency and liquid cooled with plain water or water/glycol mixture.
3. All boxes can be pressure tested to classification rules. Fabrication by coded welders.
4. Ratio gearbox driving a trapezoidal threaded lead screw ensuring self-weight support of the thruster. Raise / lower limit switches and indicators.
5. Locking pin engages when thruster is in the raised position (optional on 250/300 series). Manual over-ride system for raise / lower mechanism and locking pin.
6. Aluminium or Aluminium bronze (AB2) cast hub with fill and drain ports. Twin contra rotating aluminium bronze (AB2), four-blade propellers, matched specifically for the power requirements of the thruster.
7. A matched set of spiral bevel gears (two x crown wheels, one x pinion gear) are supported on super duplex stainless steel propeller and input shafts.
8. Hub unit protected by twin rotary shaft seals on propeller shafts, and single rotary shaft seal on the input shaft.
9. Flexible coupling between hub assembly and hydraulic motor to reduce noise and vibration.
10. Factory test and inspection reports provided with all units.



OUTER BOX



GEARBOX & LEAD SCREW



PROXIMITY SWITCHES



HYDRAULIC / ELECTRIC LOCKING PIN



TWIN CONTRA ROTATING PROPELLERS

HYDRAULIC SWING THRUSTER



PERMANENT MAGNET MOTOR ELECTRIC SWING THRUSTER





Swing Thruster

Hydraulic

Size Range: (-0250 to -1200)

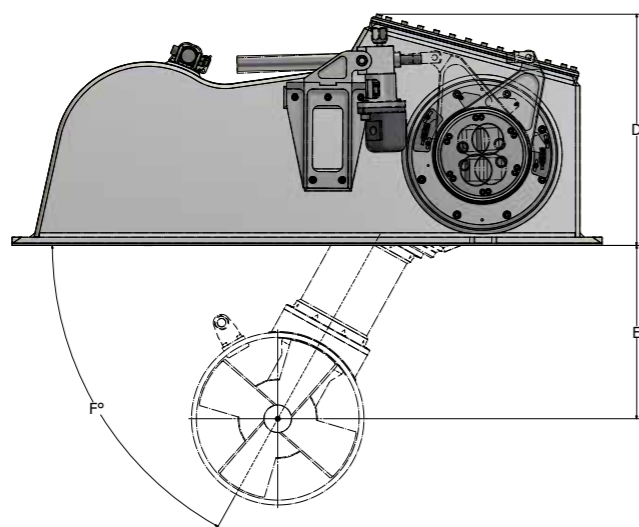
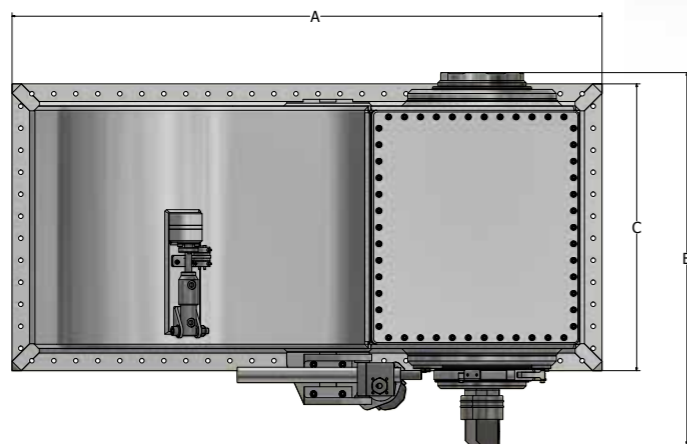

Model Number	Power (Max) (kw)	Thrust Developed (kg)	Prop Dia Nominal (mm)	A (mm)	B (mm)	C (mm)	D (mm)	E (mm)	F° (°)
H-0250-S	25	300	255	740	566	360	312	205	60
H-0300-S	36	432	305	888	679	432	375	246	60
H-0400-S	63	756	406	1347	936	634	571	455	60
H-0500-S	99	1188	508	1525	1028	725	600	528	60
H-0600-S	142	1704	610	1748	1347	853	646	617	60
H-0700-S	194	2328	711	2040	1572	1005	766	720	60
H-0800-S	252	2772	813	2334	1797	1149	862	823	60
H-1000-S	393	4323	1016	2917	2248	1437	1079	1030	60
H-1200-S	565	6215	1219	3077	2178	1540	1219	1159	60

Custom / non standard sizes available upon request.
x - Sizes for applications on request.



Swing Thruster

Electric

Size Range: (-0250 to -1200)

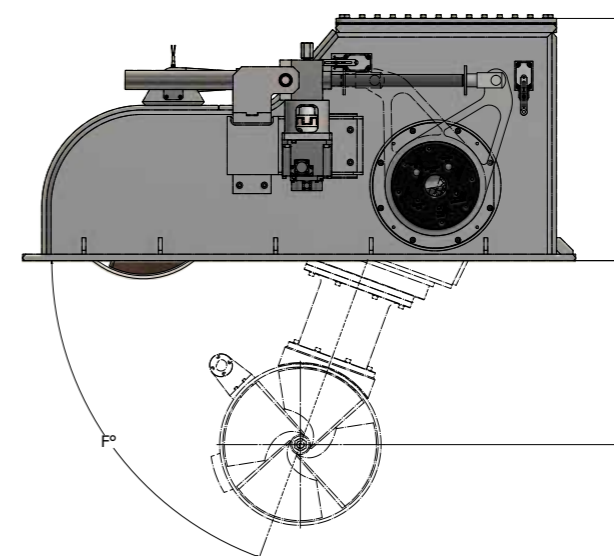
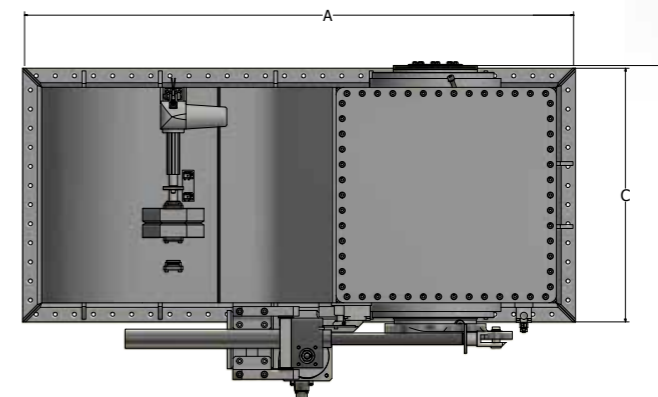

Model Number	Power (Max) (kw)	Thrust Developed (kg)	Prop Dia Nominal (mm)	A (mm)	B (mm)	C (mm)	D (mm)	E (mm)	F° (°)
E-0250-S	25	300	255	x	x	x	x	x	x
E-0300-S	36	432	305	1250	708	602	520	246	60
E-0400-S	63	756	406	1447	909	751	644	482	60
E-0500-S	99	1188	508	1588	1085	871	759	572	60
E-0600-S	142	1704	610	1863	1155	934	834	617	60
E-0700-S	194	2328	711	2084	1238	1047	934	800	60
E-0800-S	252	2772	813	2238	1349	1013	925	852	60
E-1000-S	393	4323	1016	2775	1662	1602	1082	961	60
E-1200-S	565	6215	1219	x	x	x	x	x	x

Custom / non standard sizes available upon request.
x - Sizes for applications on request.



Fixed Drive Leg

OMS Thrusters



IMAGE: GUNBOAT

D series fixed drive legs are a range of the most compact, lightweight and versatile units available on the market. They have been developed from the same technology used in our range of steerable and retracting thruster and drive designs.

The drive leg can be connected via a coupling to a traditional diesel engine, hydraulic or electric motor. The legs are designed to be simple to install, easy to maintain and provide a compact solution. Designed to work with large fixed or folding props, the OMS drive leg is suitable for sail and powerboat applications. The standard leg comes with a 2:1 ratio however OMS is able to customise the gears, powering and length/depth of leg to suit.

Technical Details

OMS Thrusters

1. Electric, hydraulic or diesel shaft driven.
2. Available as a high performance upgrade to replace existing saildrive installations. Lower leg assemblies are available separately to interface with existing inboard components.
3. A matched set of spiral bevel gears supported on super duplex stainless steel propeller and input shafts. Gear ratios can be adjusted to suit specific drive input requirement. Propeller shaft can be matched to any brand of fixed or folding propeller.
4. Anti-vibration mounting for smooth and quiet operation.
5. Double hull gasket and water sensor for added security.
6. Breakaway design feature to prevent hull damage on impact with debris.
7. Aluminium or Titanium leg and underwater components, aluminium elsewhere. Other materials available on request.
8. Capable of regeneration with a suitable electrical system.
9. Drive leg lubrication/oil change system to allow oil to be changed and circulated whilst afloat.
10. Flexible coupling between hub assembly and hydraulic/ electric motor to reduce noise and vibration.
11. Factory test and inspection reports provided with all units.



WATER SENSOR



FLEXIBLE COUPLING

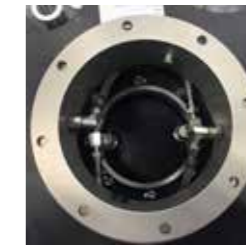

OIL CHANGE SYSTEM

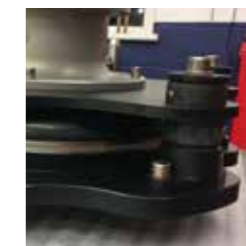

ANTI-VIBRATION MOUNTING



TITANIUM LEG



Fixed Drive Leg Electric

Size Range: (-0500 to -0750)



Model Number	Power (Max) (kw)	Prop Dia Nominal (mm)
DFA-0500-E	30	500
DFA-0575-E	75	575
DFA-0650-E	150	650
DFA-0750-E	250	750

Custom / non standard sizes available upon request.
Permanent magnet motor on request.
Hydraulic motor on request.





OMS
Ocean Marine Systems

An Introduction to OMS Hydraulics

OMS Hydraulics

Hydraulics Range

We offer a complete range of aluminium and stainless-steel cylinders. Engineered with intelligence and with performance in mind, these cylinders will integrate into most hydraulic systems controlling mast, sail and rigging combinations. Designed and built in the UK, these units are reliable, elegant and proven to suit both race and cruising requirements.

We have a proven track record in providing control cylinders to both production series yachts as well as the worlds largest superyacht applications.

In addition to cylinders, we can provide the associated pumps, power-packs and control systems that make a complete on board hydraulic solution. Custom system design and supply is offered by our highly experienced engineers.



Contact OMS for your
Hydraulics brochure



Rams



Inner Forestay
Tensioners



Mechanical Lock
Rams



Manual
Controls



Vangs



Sail Trim



DC Power Packs



Header Tanks

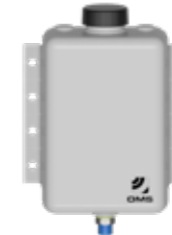

Double Pull
Travellers



Sail Trim Double



Control Manifold
Assemblies



Custom



THRUSTERS • HYDRAULICS

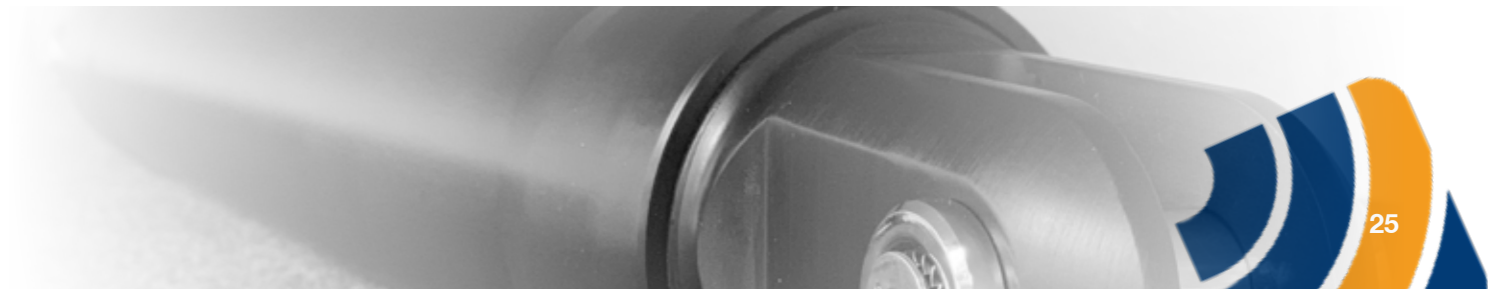



OMS
Ocean Marine Systems

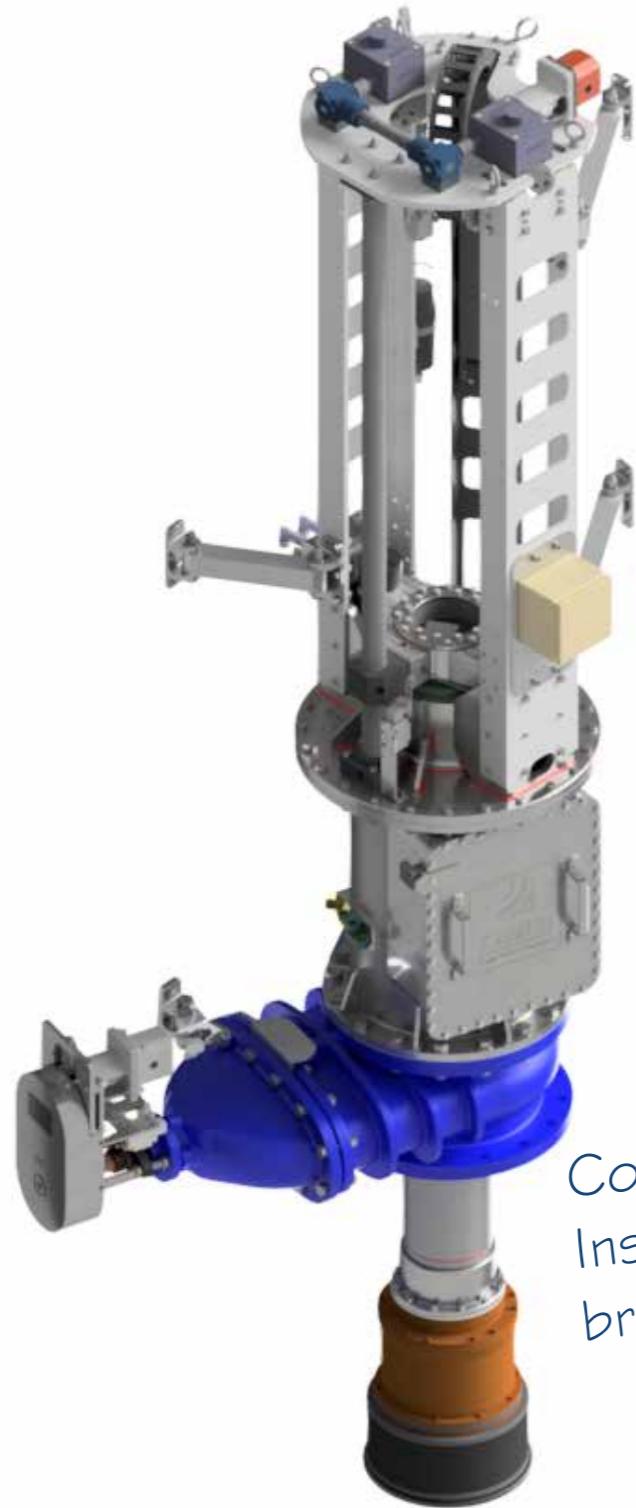

Contact OMS for your
Instrument Deployment
brochure



INSTRUMENT DEPLOYMENT

An Introduction to OMS Instrument Deployment

OMS Hydraulics

Instrument Deployment Range

OMS strive to achieve custom solutions for all applications. Instrument deployment from OMS are all designed and manufactured to order. Whilst we do have standard models, our in-house design team can work with any new or existing structure to deliver the best possible solution. Re-fitting to an existing foundation or working within a restricted envelope is also something we are always happy to discuss.

Swing Retracting Unit

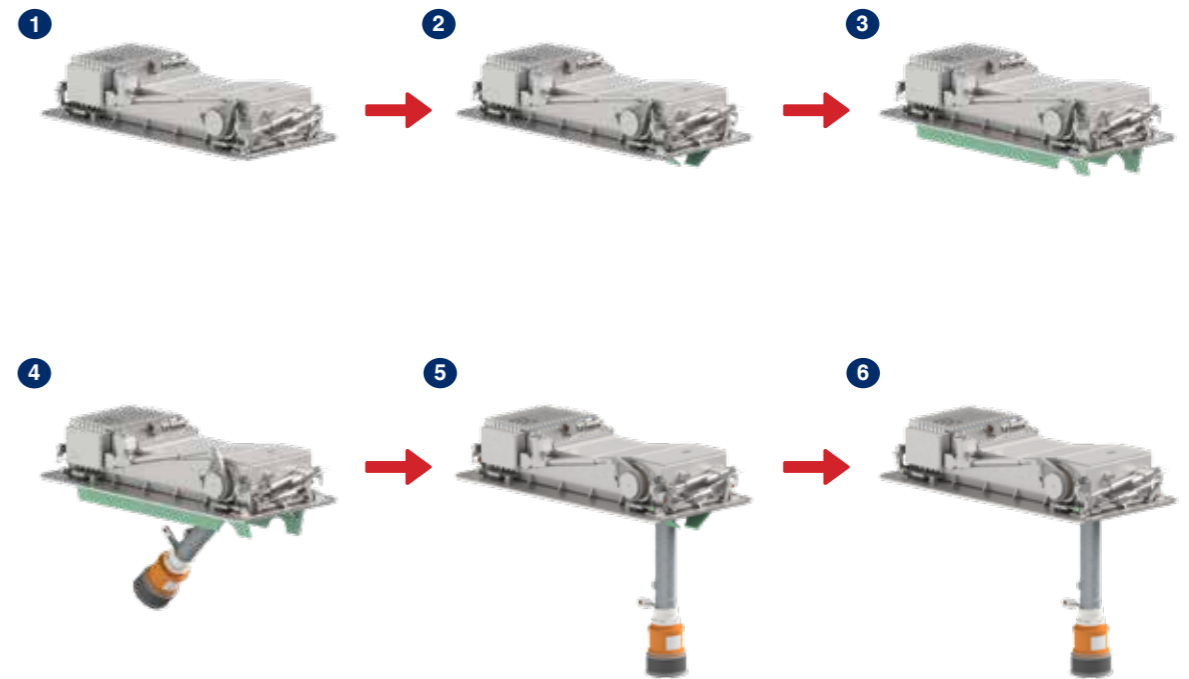

Vertical Retracting Unit

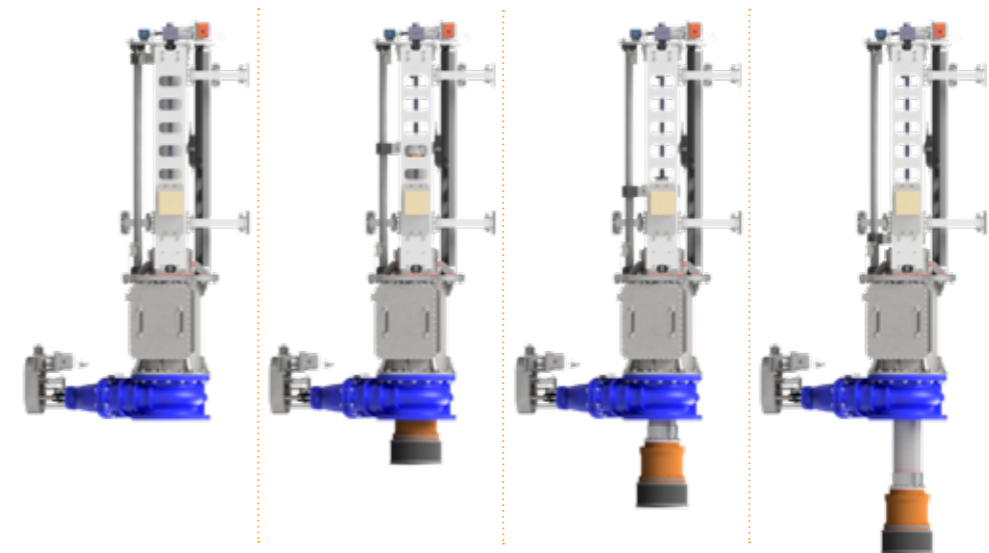

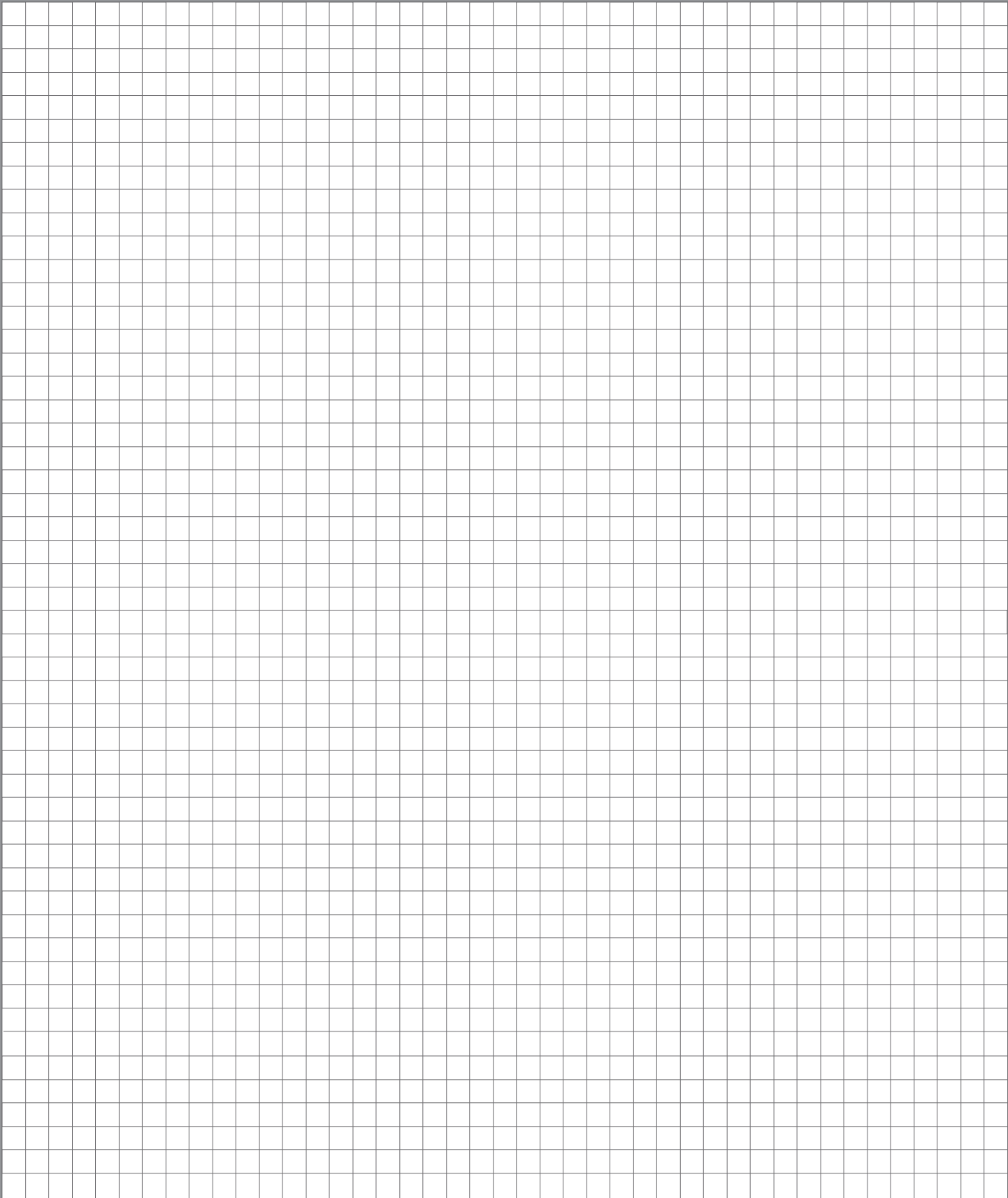

Ocean Marine Systems

Ocean House, Aviation Business Park,
Bournemouth International Airport,
Christchurch, Dorset, BH23 6NW
United Kingdom

Contact Us:

Tel: +44 (0)1202 596630

Email: mail@oms.ltd

Opening Hours: Mon - Thurs 8 am to 5 pm / Fri 8 am to 12

Web: oms.ltd

REVD