

SIZE	-0010
LENGTH	750 mm
ROD THREAD	1/2-20 UNF
BORE DIA	36 mm
ROD DIA	14 mm
STROKE	230 mm
WEIGHT	2.257 Kg
ANNULUS AREA (PULLING/RETRACTING)	864 mm ²
OIL DISPLACEMENT	0.40 ltrs
PULL FORCE @ 150 BAR	1321 Kg (12959 N)
PULL FORCE @ 250 BAR	2202 Kg (21598 N)
MAX PULL FORCE @ 350 BAR (RELIEF)	3082 Kg (30238 N)

NOTE:

1. CUSTOM VARIATIONS AND ROD THREADS ARE AVAIBALE ON REQUEST
2. ATTACHMENT METHOD CUSTOMISABLE ON REQUEST

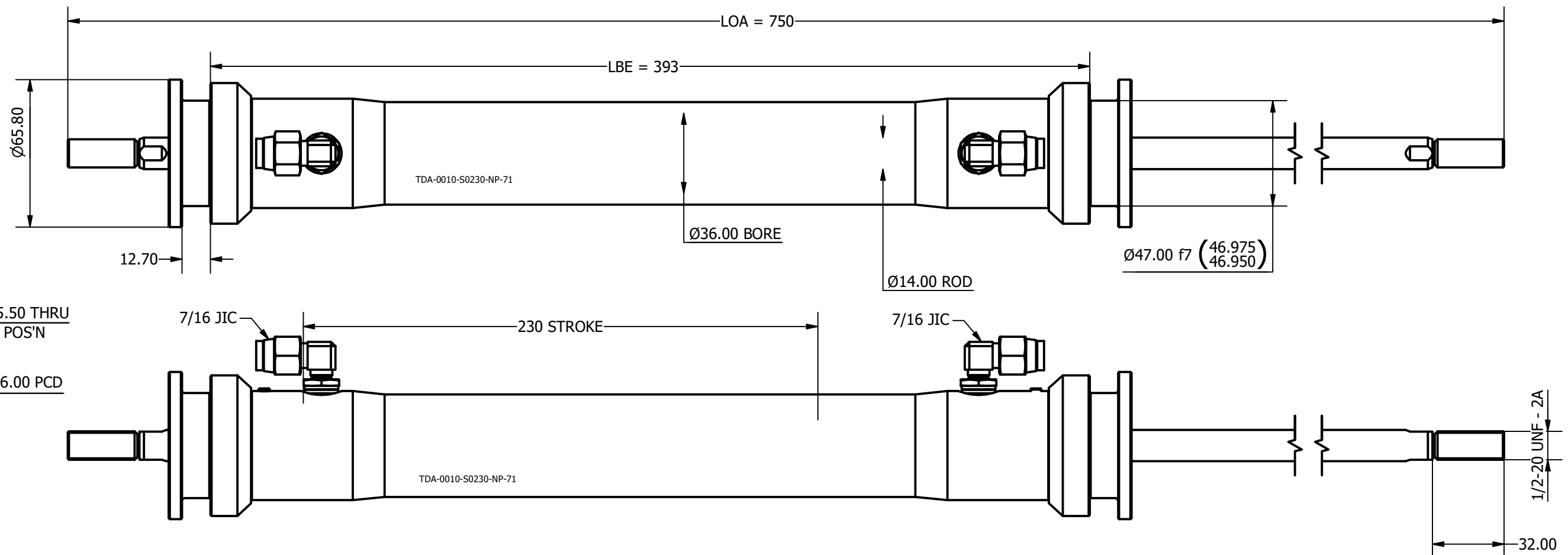

SAME MOUNTING
DETAIL BOTH ENDS

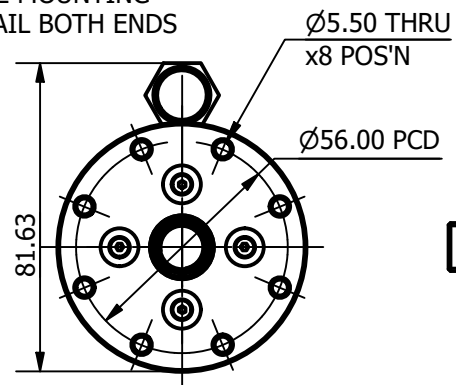

TOP SLOT SHOULD BE
LARGER THAN ROD

BRACKET HOLE SHOULD
MATCH RETAINER

BRACKET PLATE THICKNESS
SHOULD BE EQUAL TO
RETAINER GAP

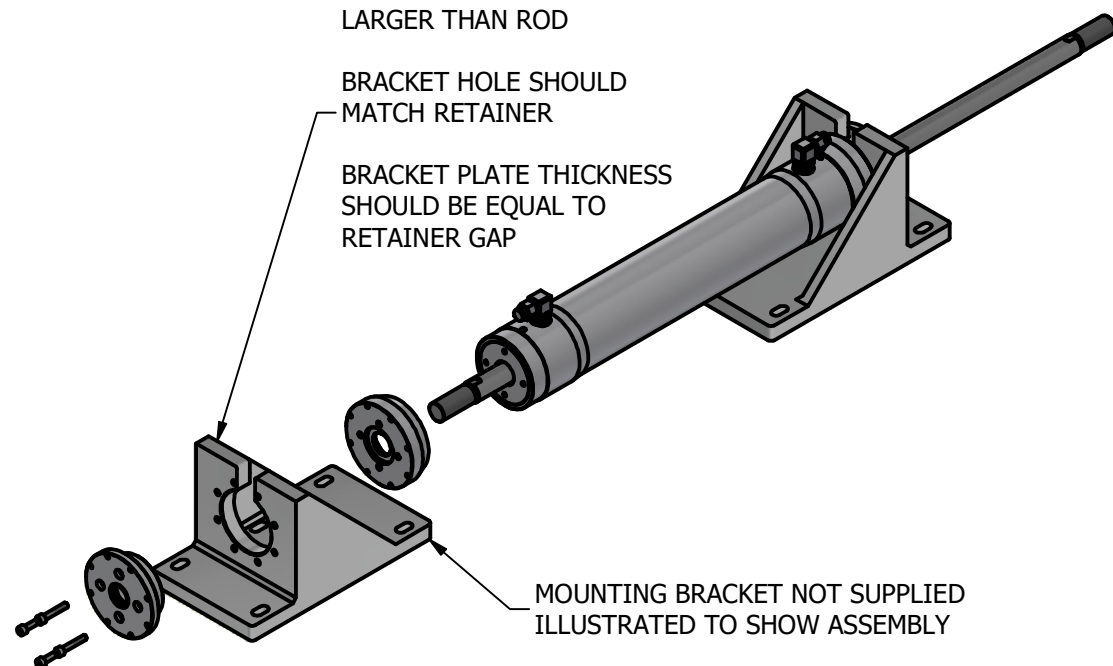

MOUNTING BRACKET NOT SUPPLIED
ILLUSTRATED TO SHOW ASSEMBLY

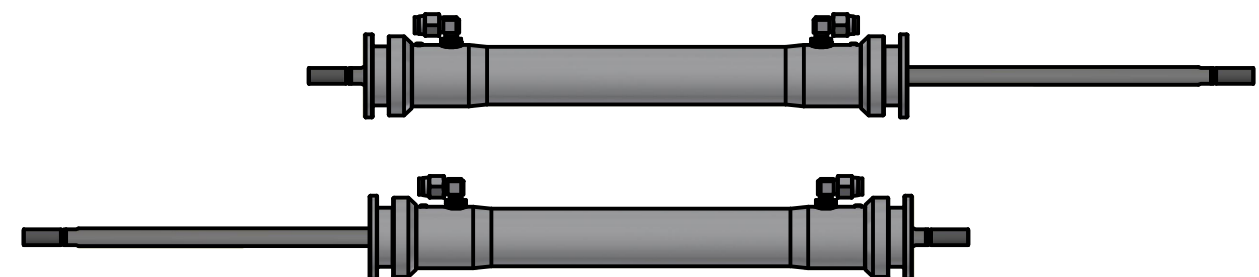

OMS
Ocean Marine Systems

Title ALUMINIUM DOUBLE PULL TRAVELLER CYLINDER		Revision 1
Drawing No. TDA-0010-S0230-NP-71		Date Drawn 02/11/2021
Tel: +44 (0)1202 596630 www.oms.ltd		By AL
© Copyright. All rights to this drawing and design are the sole property of OMS Ltd. This drawing must not be copied, communicated or loaned to any third party without the written consent of OMS Ltd.		