

SIZE	-0048
PCLC	762 mm
PIN / GAP	28.58 mm
BORE DIA	82 mm
ROD DIA	26 mm
STROKE	300 mm
WEIGHT	29.58 Kg
FULL BORE AREA (PUSHING/EXTENDING)	5281 mm ²
ANNULUS AREA (PULLING/RETRACTING)	4750 mm ²
OIL DISPLACEMENT (FULL BORE SIDE)	1.58 ltrs
OIL DISPLACEMENT (ANNULUS SIDE)	1.43 ltrs
MAXIMUM PUSH FORCE @ 5 BAR	269 Kg (2641 N)
PULL FORCE @ 150 BAR	7263 Kg (71251 N)
PULL FORCE @ 250 BAR	12105 Kg (118752 N)
MAX PULL FORCE @ 350 BAR (RELIEF)	16947 Kg (166253 N)

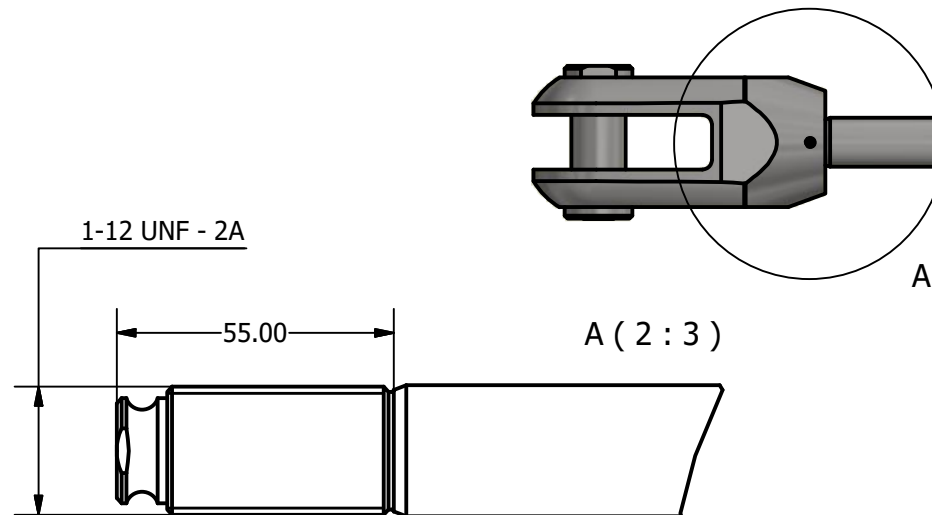

NOTE: CUSTOM STROKES, LENGTHS AND CLEVIS DIMENSIONS AVAILABLE UPON REQUEST

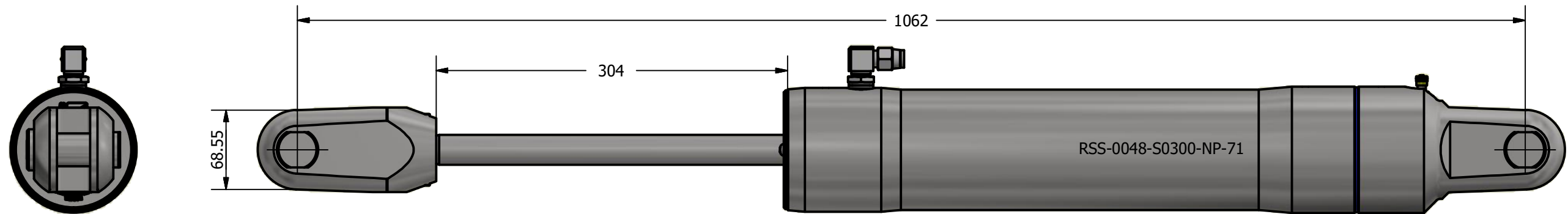
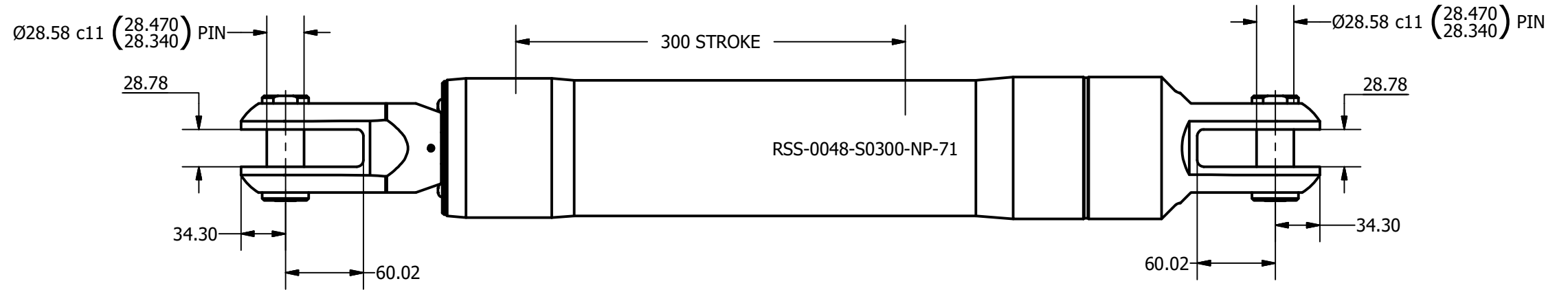
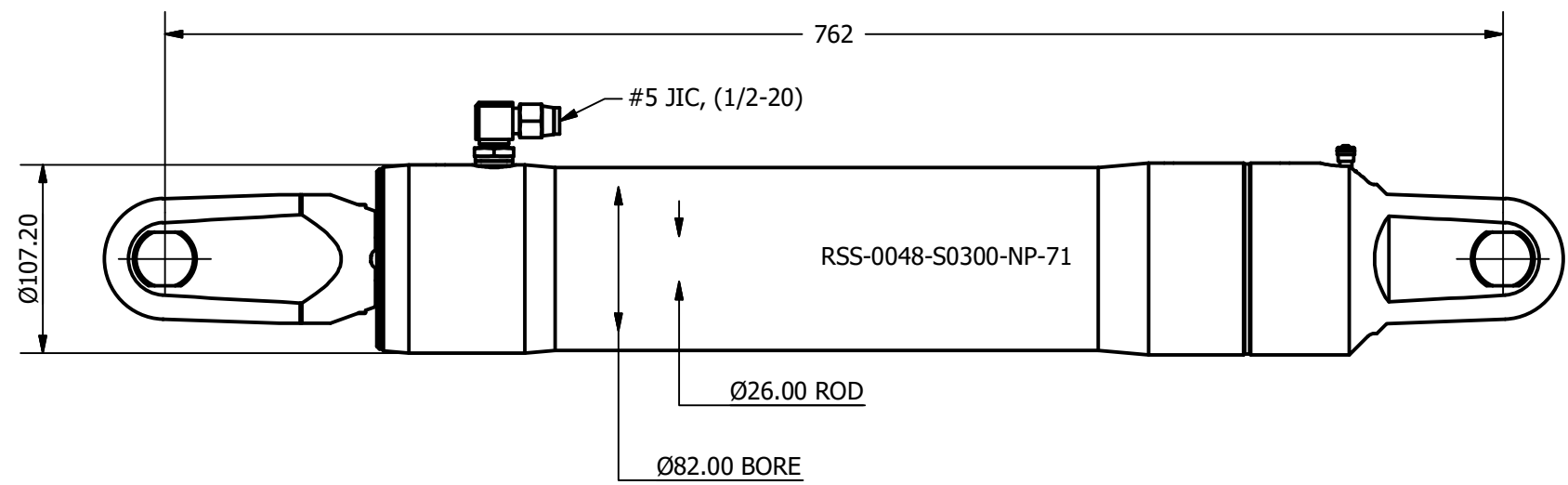

OMS
Ocean Marine Systems

Title STAINLESS SINGLE ACTING GAS RETURN CYLINDER		Revision 2
Drawing No. RSS-0048-S0300-NP-71	Date Drawn 10/11/2021	By AL
Tel: +44 (0)1202 596630 www.oms.ltd		© Copyright. All rights to this drawing and design are the sole property of OMS Ltd. This drawing must not be copied, communicated or loaned to any third party without the written consent of OMS Ltd.