

SIZE -0006
 PCLC 778 mm
 PIN / GAP 11.11 mm
 BORE DIA 26 mm
 ROD DIA 12 mm
 STROKE 510 mm
 WEIGHT 1.72 Kg
 FULL BORE AREA (PUSHING/EXTENDING) 531 mm²
 ANNULUS AREA (PULLING/RETRACTING) 418 mm²
 GAS DISPLACEMENT (FULL BORE SIDE) 0.27 ltrs
 OIL DISPLACEMENT (ANNULUS SIDE) 0.21 ltrs
 MAXIMUM PUSH FORCE @ 4 BAR 22 Kg (212 N)
 PULL FORCE @ 150 BAR 639 Kg (6267 N)
 PULL FORCE @ 250 BAR 1065 Kg (10446 N)
 MAX PULL FORCE @ 350 BAR (RELIEF) 1491 Kg (14624 N)

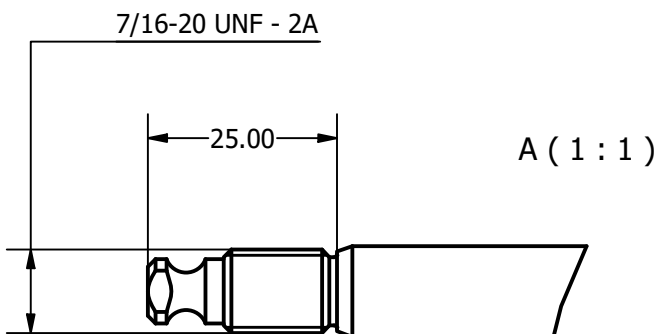
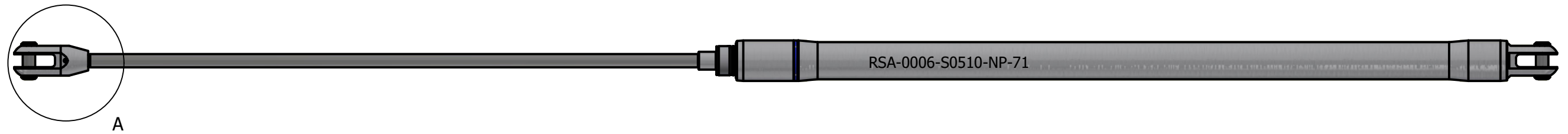
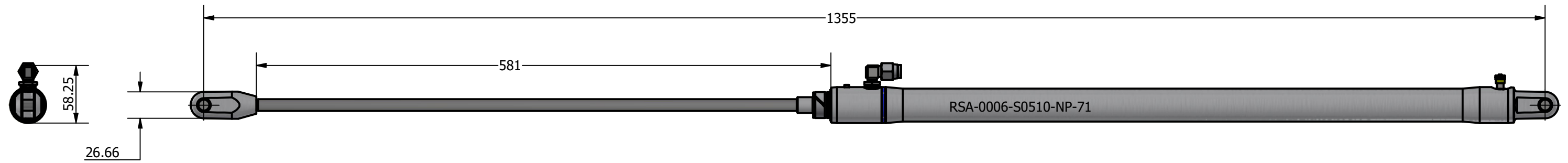
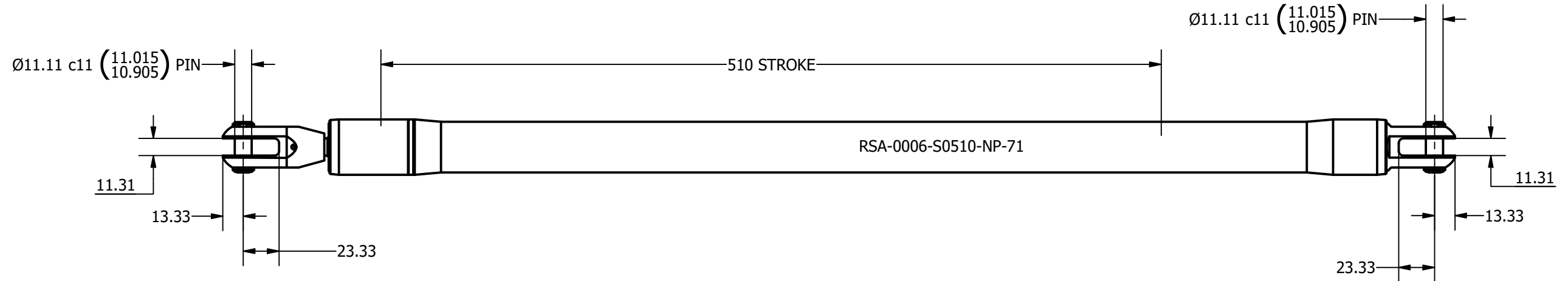
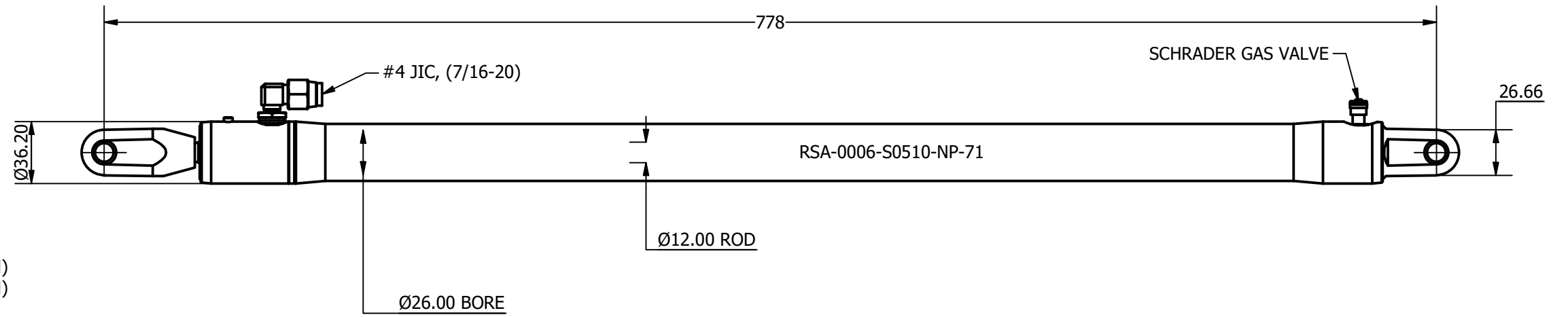

NOTE: CUSTOM STROKES, LENGTHS AND CLEVIS DIMENSIONS AVAILABLE UPON REQUEST

	Title ALUMINIUM SINGLE ACTING GAS RETURN CYLINDER		Revision 3
	Drawing No. RSA-0006-S0510-NP-71		Date Drawn 20/10/2021
	Tel: +44 (0)1202 596630 www.oms.ltd		By AL

© Copyright. All rights to this drawing and design are the sole property of OMS Ltd. This drawing must not be copied, communicated or loaned to any third party without the written consent of OMS Ltd.