

SIZE	-0040
PCLC	1146 mm
PIN / GAP	25.4 mm
BORE DIA	78 mm
ROD DIA	26 mm
STROKE	300 mm
WEIGHT	16.48 Kg
FULL BORE AREA (PUSHING/EXTENDING)	4778 mm ²
ANNULUS AREA (PULLING/RETRACTING)	4247 mm ²
GAS DISPLACEMENT (FULL BORE SIDE)	1.43 ltrs
OIL DISPLACEMENT (ANNULUS SIDE)	1.27 ltrs
MAXIMUM PUSH FORCE @ 5 BAR	244 Kg (2389 N)
PULL FORCE @ 150 BAR	6495 Kg (63711 N)
PULL FORCE @ 250 BAR	10824 Kg (106186 N)
MAX PULL FORCE @ 350 BAR (RELIEF)	15154 Kg (148660 N)

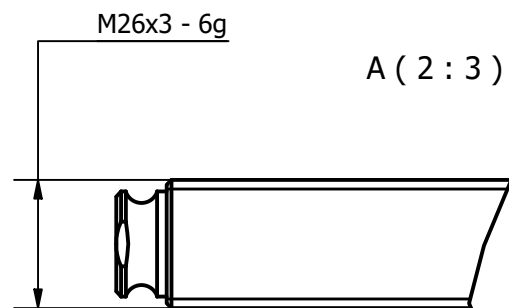
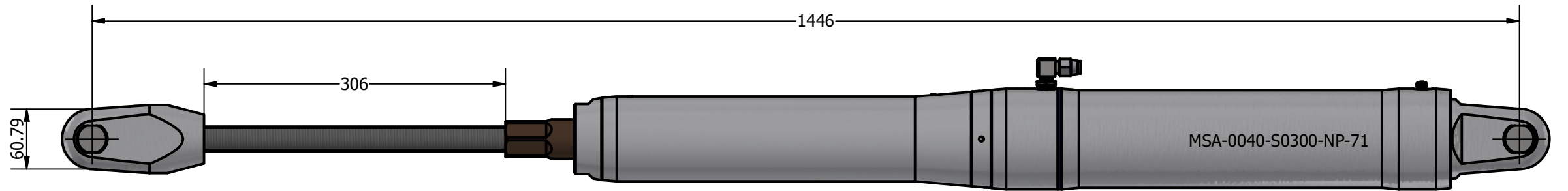
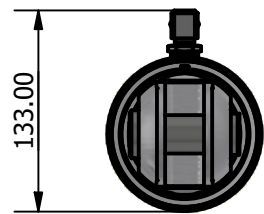
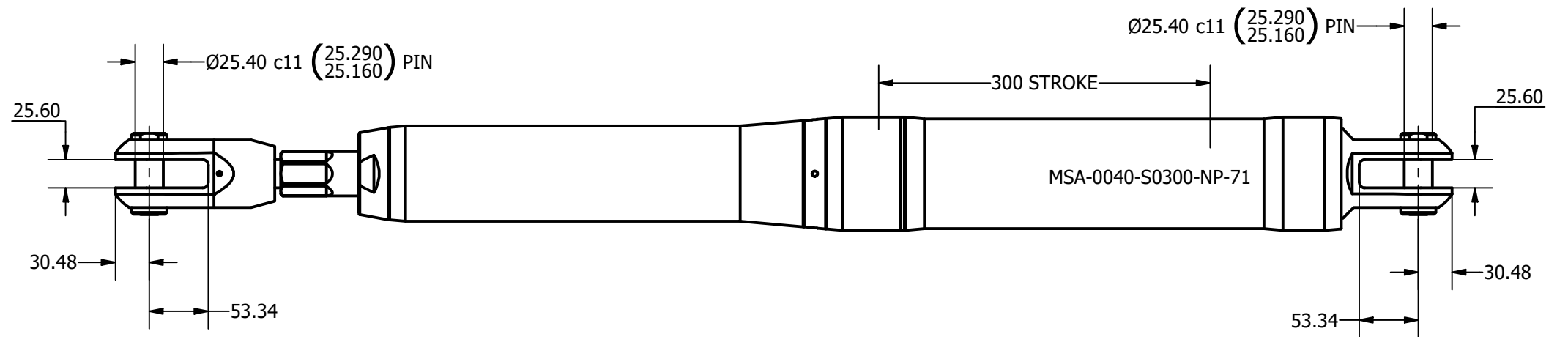
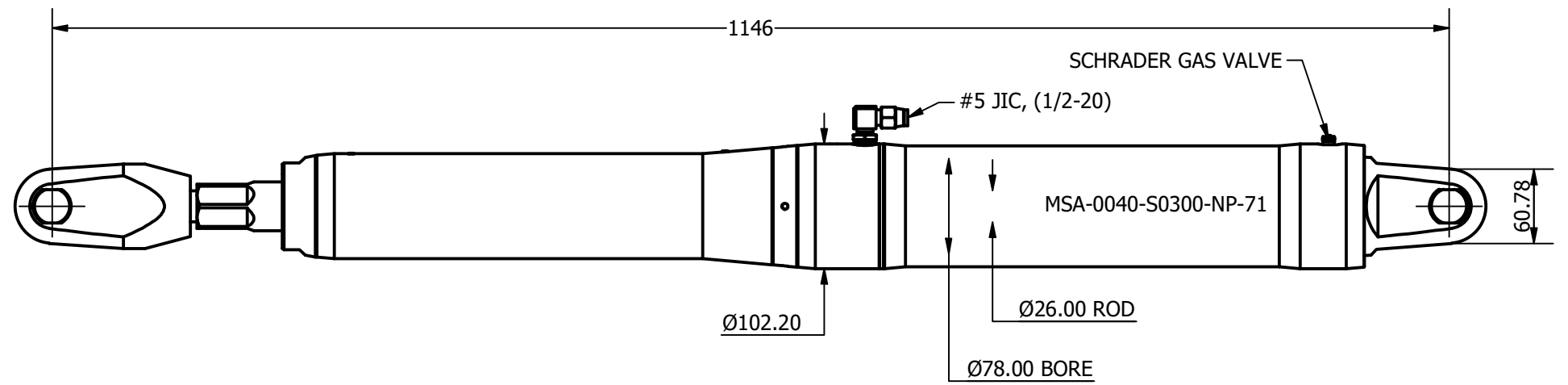

NOTE: CUSTOM STROKES, LENGTHS AND CLEVIS DIMENSIONS AVAILABLE UPON REQUEST

	Title ALUMINIUM SINGLE ACTING MECHANICAL LOCK CYLINDER		Revision 2
	Drawing No. MSA-0040-S0300-NP-71		Date Drawn By 29/10/2021 AL
	Tel: +44 (0)1202 596630 www.oms.ltd		© Copyright. All rights to this drawing and design are the sole property of OMS Ltd. This drawing must not be copied, communicated or loaned to any third party without the written consent of OMS Ltd.