

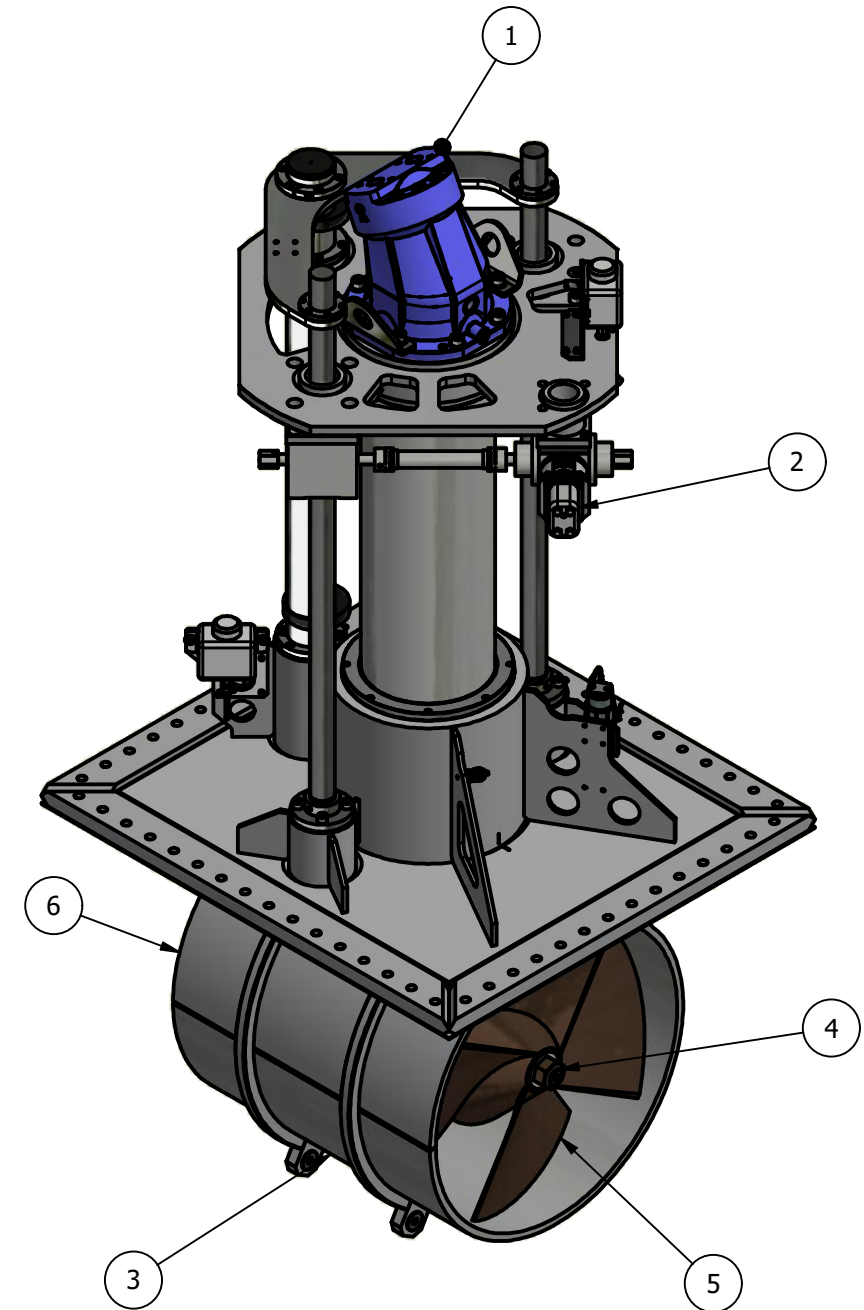

ITEM	QTY	DESCRIPTION
1	1	HYDRAULIC MAIN DRIVE MOTOR
2	1	HYDRAULIC LIFT MECHANISM
3	1	TUNNEL ASSEMBLY
4	1	POD ASSEMBLY
5	1	PROPELLER 1
6	1	PROPELLER 2
7	2	PROXIMITY SENSOR

NOMINAL PROP DIA	800mm
POWER RANGE	194-252Kw (260-338hp)
MIN / MAX THRUST	2328-2772kgf (5132-6111lbf)
WEIGHT APPROXIMATELY	1660kg (3660lb)
STANDARD PRESSURE	330 Bar
NOMINAL FLOW	505 L/min

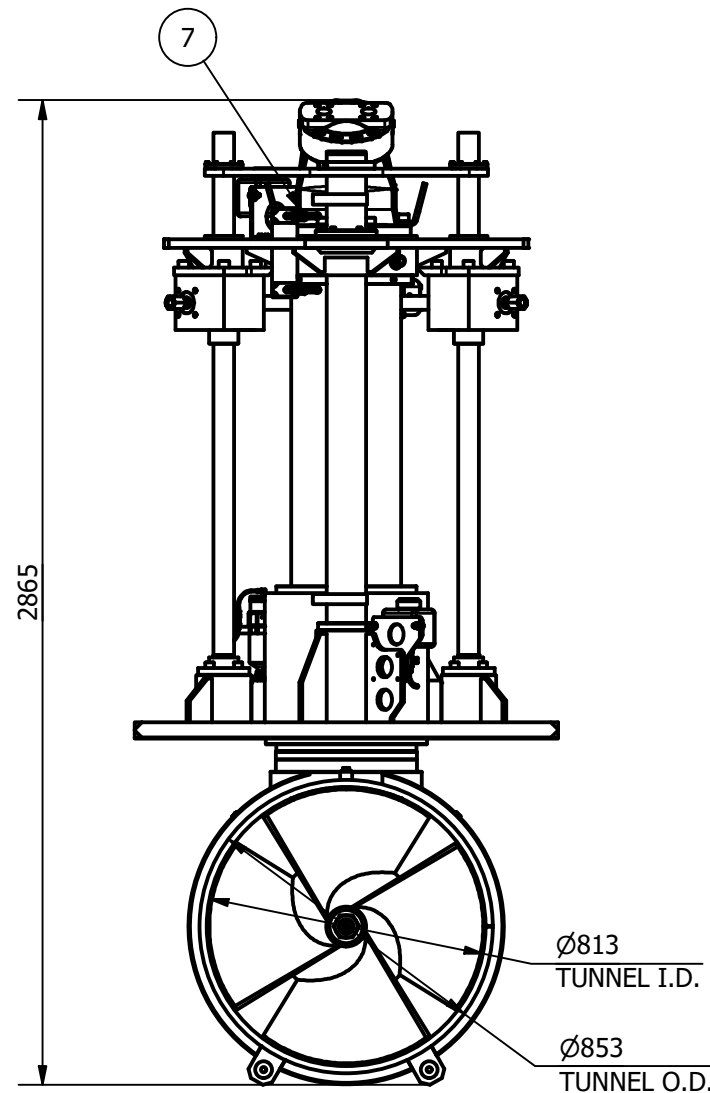
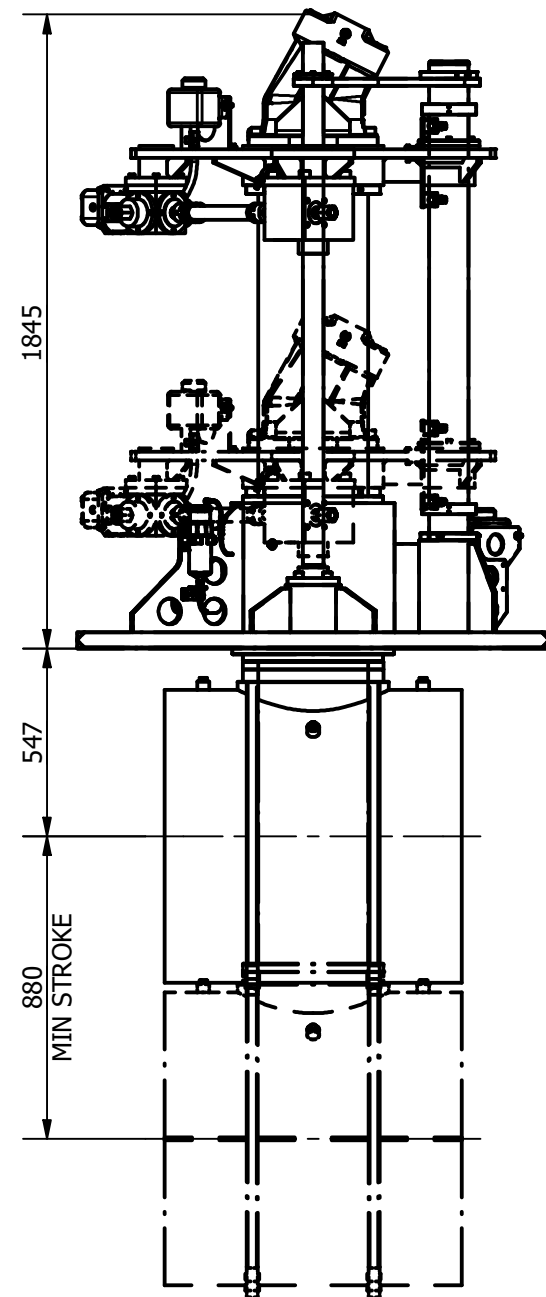
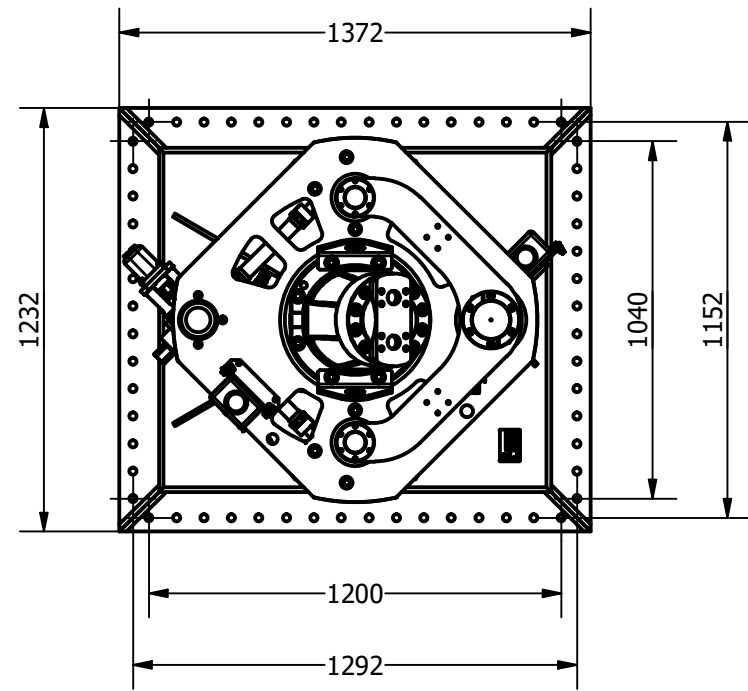

	Title VERTICAL RETRACT THRUSTER - HYDRAULIC				Revision 2		Dimensions in millimeters & degrees		
	Drawing No. H-0800-V		Material		Finish		Gen. Tolerance ± 0.2 Gen. Finish 3.2		
Tel: +44 (0)1202 596630 www.oceanmarinesystems.co.uk		Sheet 1 of 1	Scale NTS @ A3	Mass N/A	Date Drawn 17/03/2020	By CR	Modified Date	By	 <i>If in doubt ask!</i>
© Copyright. All rights to this drawing and design are the sole property of Ocean Marine Systems Ltd. This drawing must not be copied, communicated or loaned to any third party without the written consent of Ocean Marine Systems Ltd.									Cert. Y Insp. III Grade A