

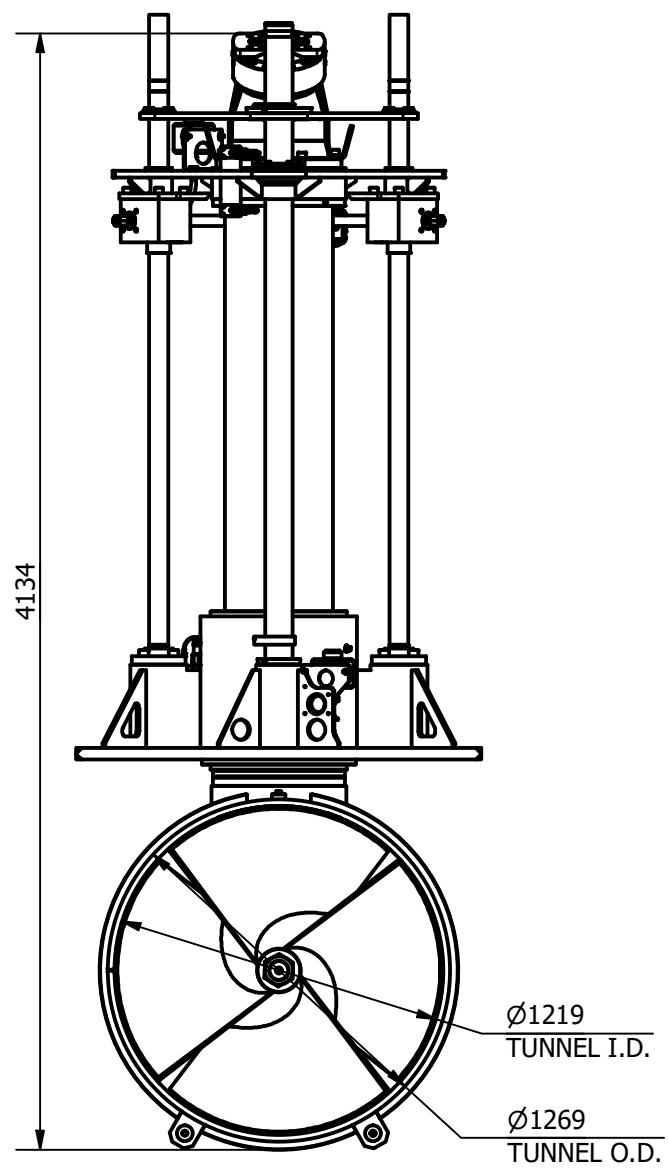

ITEM	QTY	DESCRIPTION
1	1	HYDRAULIC MAIN DRIVE MOTOR
2	1	HYDRAULIC LIFT MECHANISM
3	1	TUNNEL ASSEMBLY
4	1	POD ASSEMBLY
5	1	PROPELLER 1
6	1	PROPELLER 2
7	2	PROXIMITY SENSOR

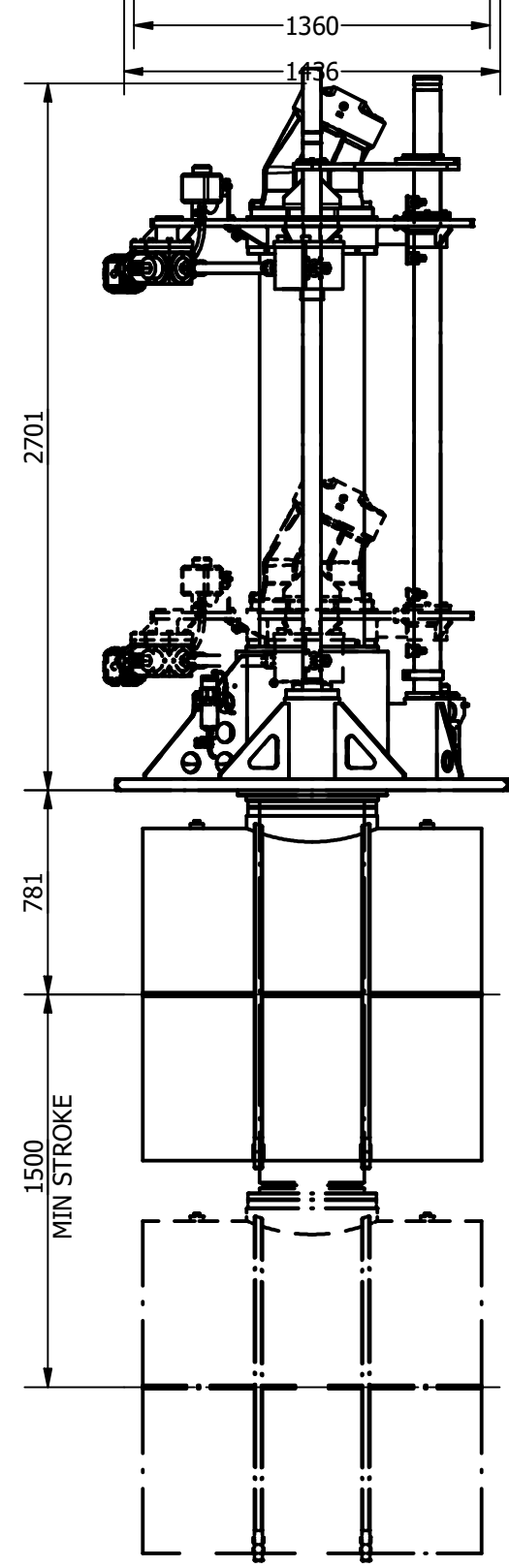

NOMINAL PROP DIA	1200mm
POWER RANGE	393-565Kw (527-758hp)
MIN / MAX THRUST	4323-6215kgf (9506-13702lbf)
WEIGHT APPROXIMATELY	3350kg (7385lb)
STANDARD PRESSURE	350 Bar
NOMINAL FLOW	1070 L/min

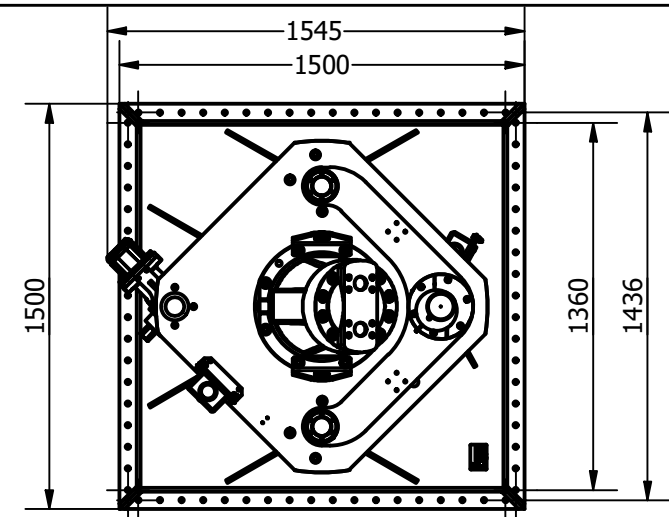
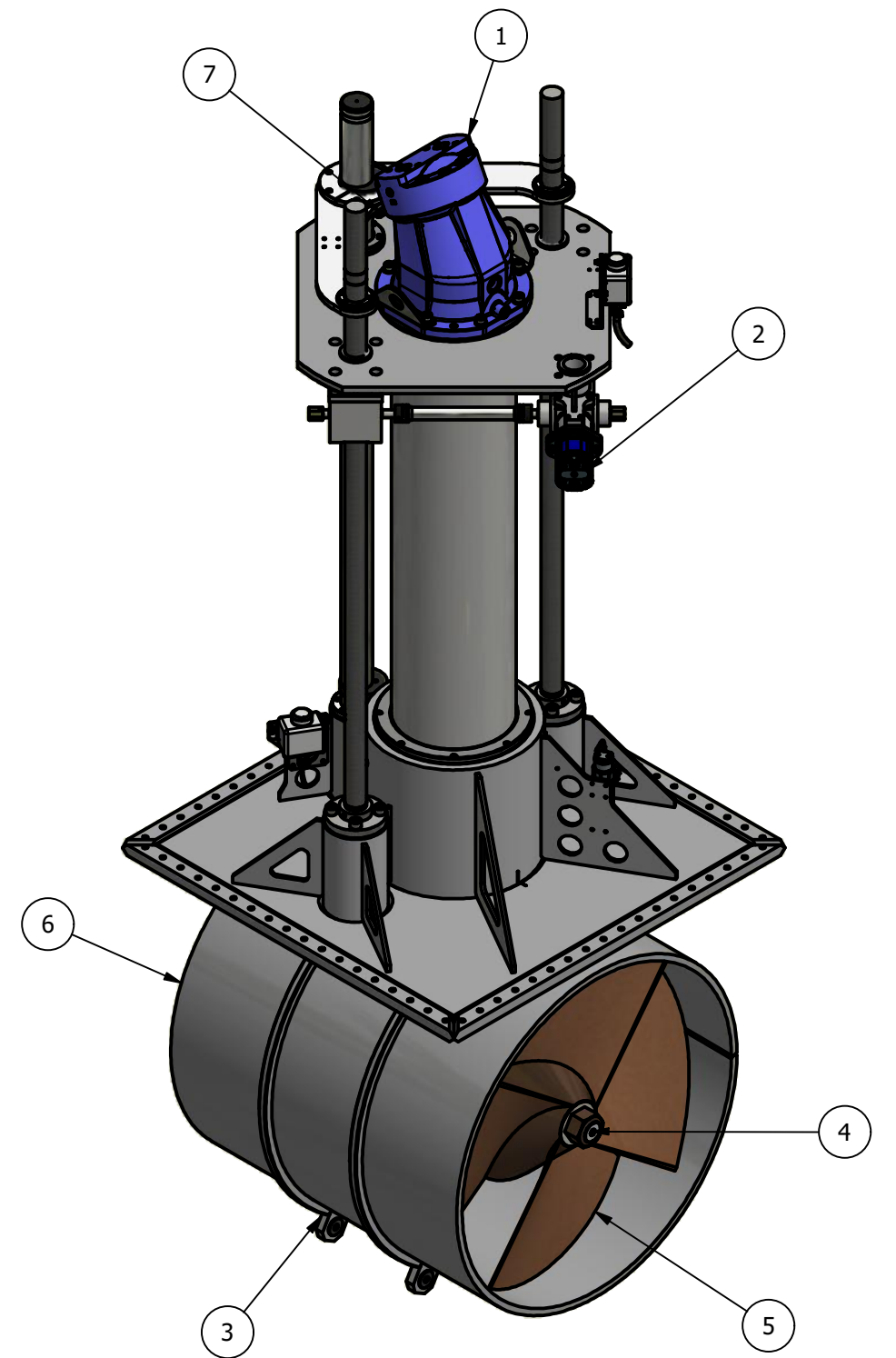

 <p>Tel: +44 (0)1202 596630 www.oceanmarinesystems.co.uk</p>	Title VERTICAL RETRACT THRUSTER - HYDRAULIC				Revision 1		Dimensions in millimeters & degrees Gen. Tolerance ± 0.2 Gen. Finish 3.2 ✓		
	Drawing No. H-1200-V		Material		Finish				
Sheet 1 of 1	Scale NTS @ A3	Mass N/A	Date Drawn 18/03/2020	By CR	Modified Date	By	Cert. Y	Insp. III	Grade A

© Copyright. All rights to this drawing and design are the sole property of Ocean Marine Systems Ltd. This drawing must not be copied, communicated or loaned to any third party without the written consent of Ocean Marine Systems Ltd.