

ITEM	QTY	DESCRIPTION
1	1	POD ASSEMBLY
2	1	OUTER BOX ASSEMBLY
3	1	SWING BOX ASSEMBLY
4	1	TUNNEL ASSEMBLY
5	1	LIFTING MECHANISM
6	1	PROPELLER 1
7	1	PROPELLER 2

Note:
 • Swing mechanism and hydraulic hose points can be mounted either side of the outer box assembly

NOMINAL PROP DIA	1200mm
POWER RANGE	393-565Kw (527-758hp)
MIN / MAX THRUST	4323-6215kgf (9531-13702lbf)
WEIGHT APPROXIMATELY	3915kg (8631lb)
STANDARD PRESSURE	350 BAR
NOMINAL FLOW	1070 L/min

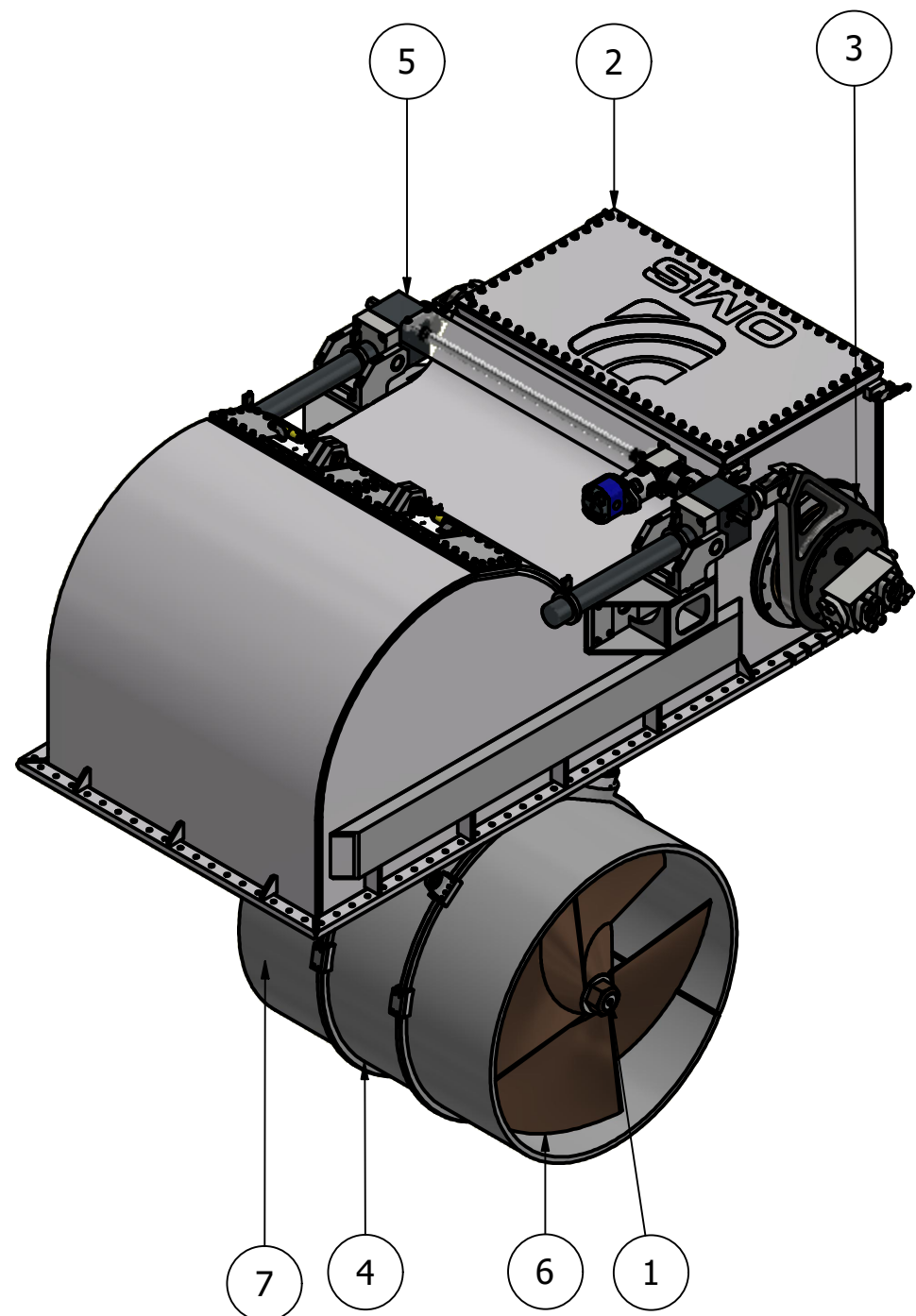
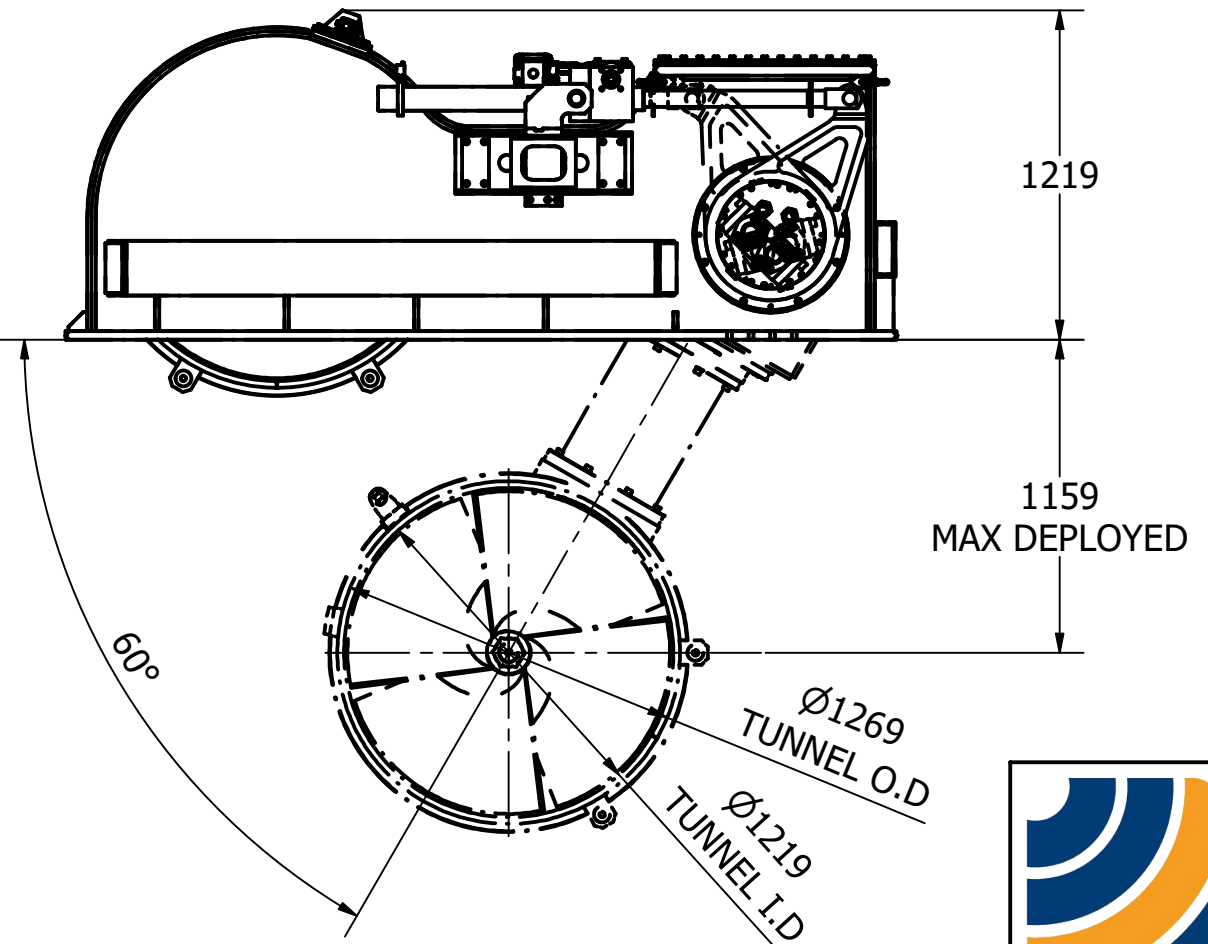
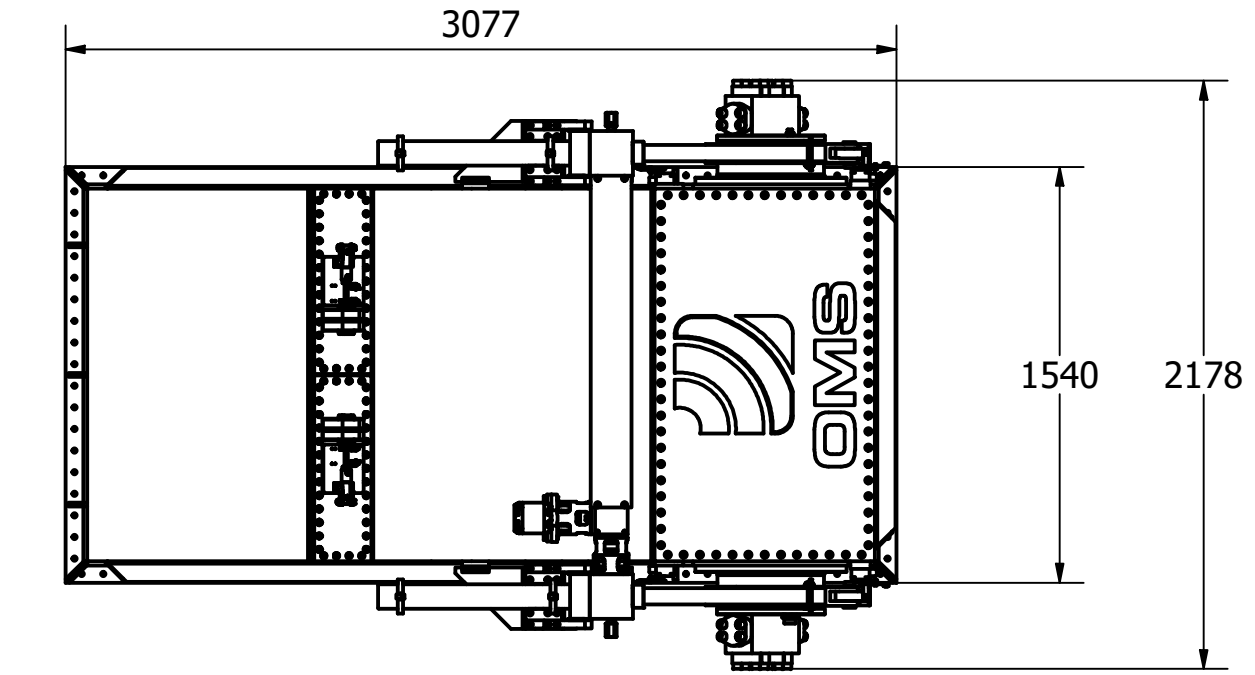

Title SWING THRUSTER - HYDRAULIC		Revision 2
Drawing No. H-1200-S		Date Drawn By 11/11/2021 AL
Tel: +44 (0)1202 596630 www.oms.ltd		© Copyright. All rights to this drawing and design are the sole property of OMS Ltd. This drawing must not be copied, communicated or loaned to any third party without the written consent of OMS Ltd.