

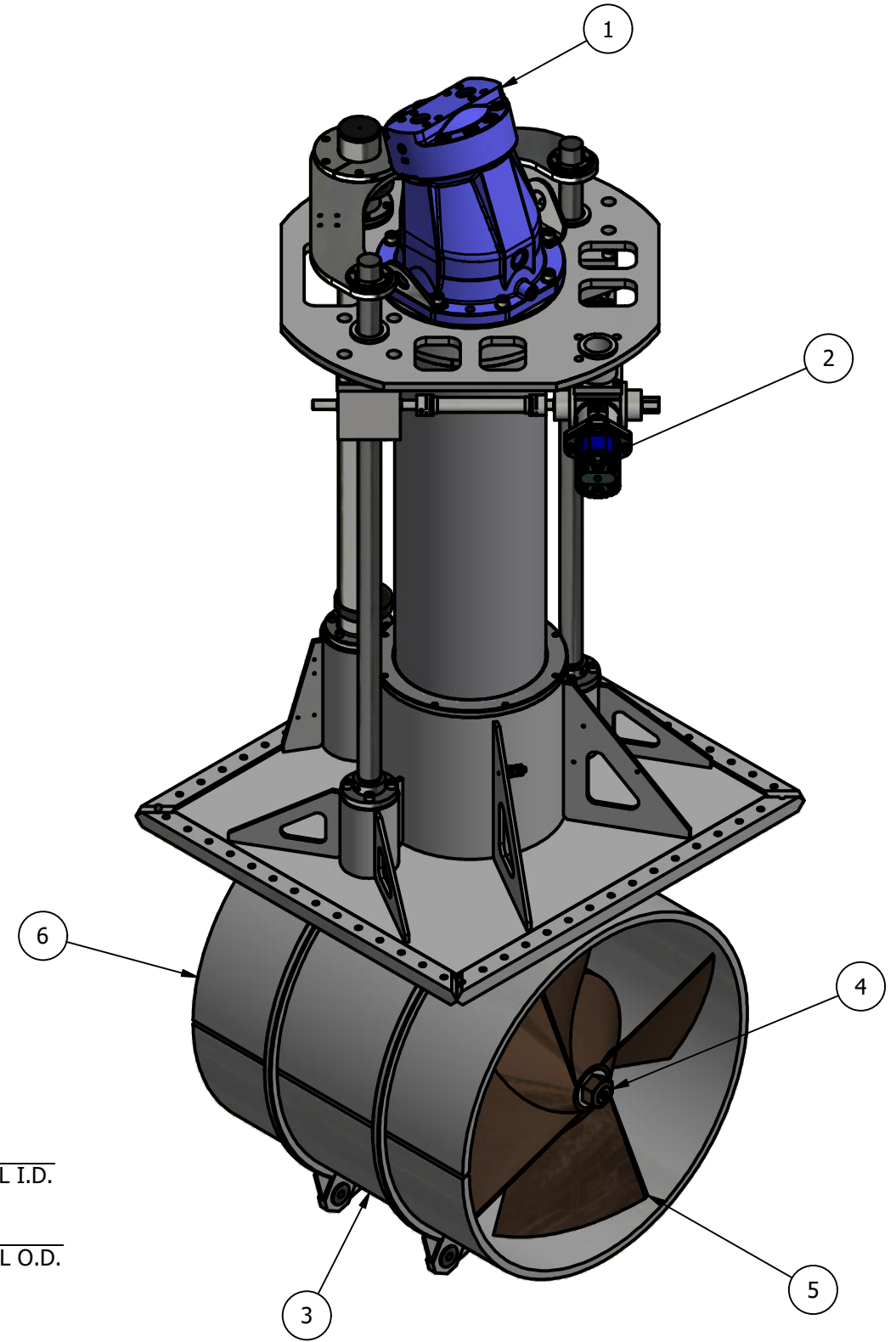

ITEM	QTY	DESCRIPTION
1	1	HYDRAULIC MAIN DRIVE MOTOR
2	1	HYDRAULIC LIFT MECHANISM
3	1	TUNNEL ASSEMBLY
4	1	POD ASSEMBLY
5	1	PROPELLER 1
6	1	PROPELLER 2
7	2	PROXIMITY SENSOR

NOMINAL PROP DIA	1000mm
POWER RANGE	252-393Kw (338-527hp)
MIN / MAX THRUST	2772-4323kgf (6111-9506lbf)
WEIGHT APPROXIMATELY	2402kg (5296lb)
STANDARD PRESSURE	330 Bar
NOMINAL FLOW	800 L/min

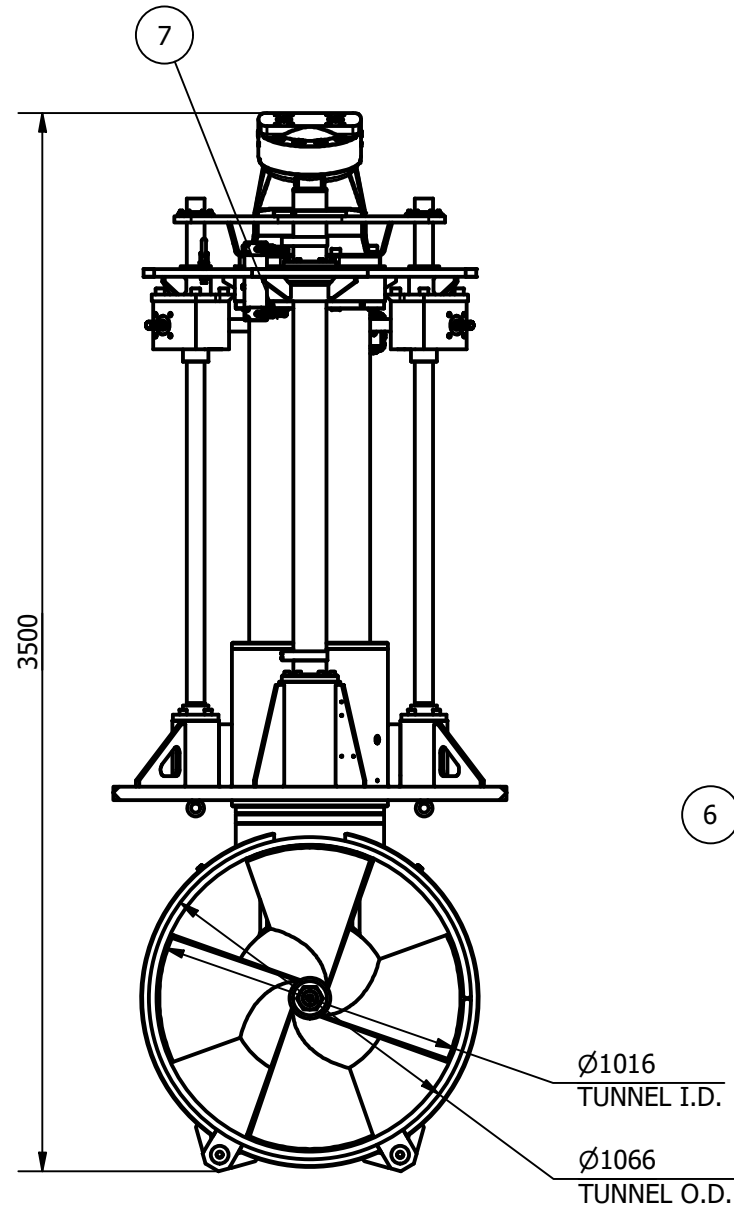
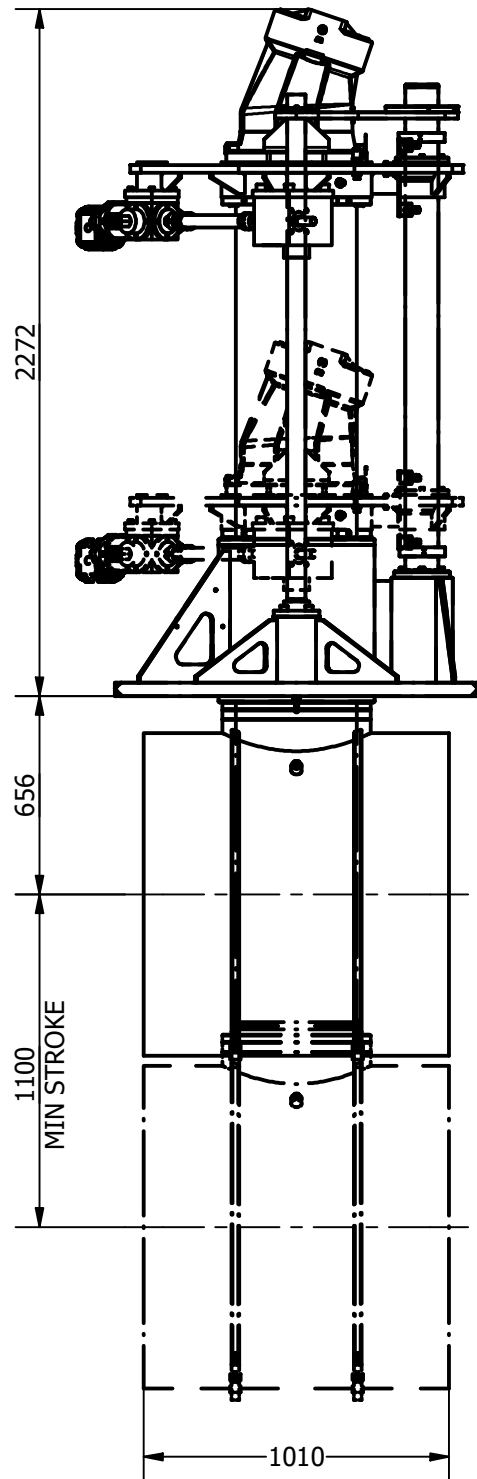
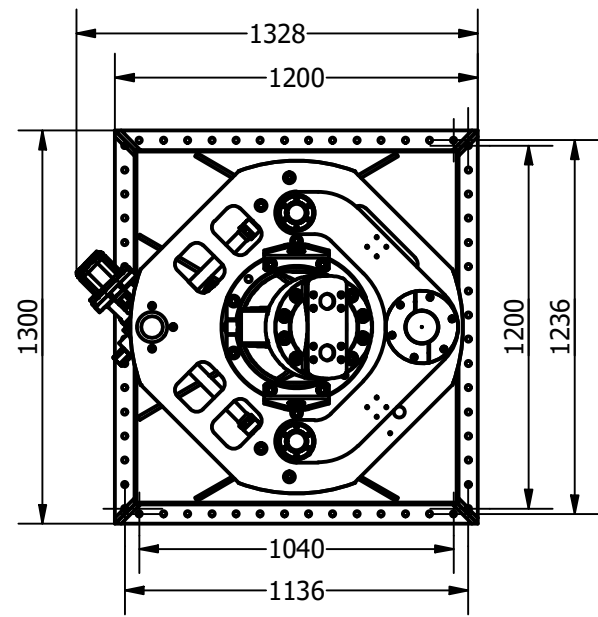

 <p>Tel: +44 (0)1202 596630 www.oceanmarinesystems.co.uk</p>	Title VERTICAL RETRACT THRUSTER - HYDRAULIC		Revision 2		Dimensions in millimeters & degrees Gen. Tolerance ± 0.2 Gen. Finish 3.2	
	Drawing No. H-1000-V		Material	Finish		 If in doubt ask!
Sheet 1 of 1	Scale NTS @ A3	Mass N/A	Date Drawn 18/03/2020	By CR	Modified Date	
© Copyright. All rights to this drawing and design are the sole property of Ocean Marine Systems Ltd. This drawing must not be copied, communicated or loaned to any third party without the written consent of Ocean Marine Systems Ltd.		Cert. Y	Insp. III	Grade A		