

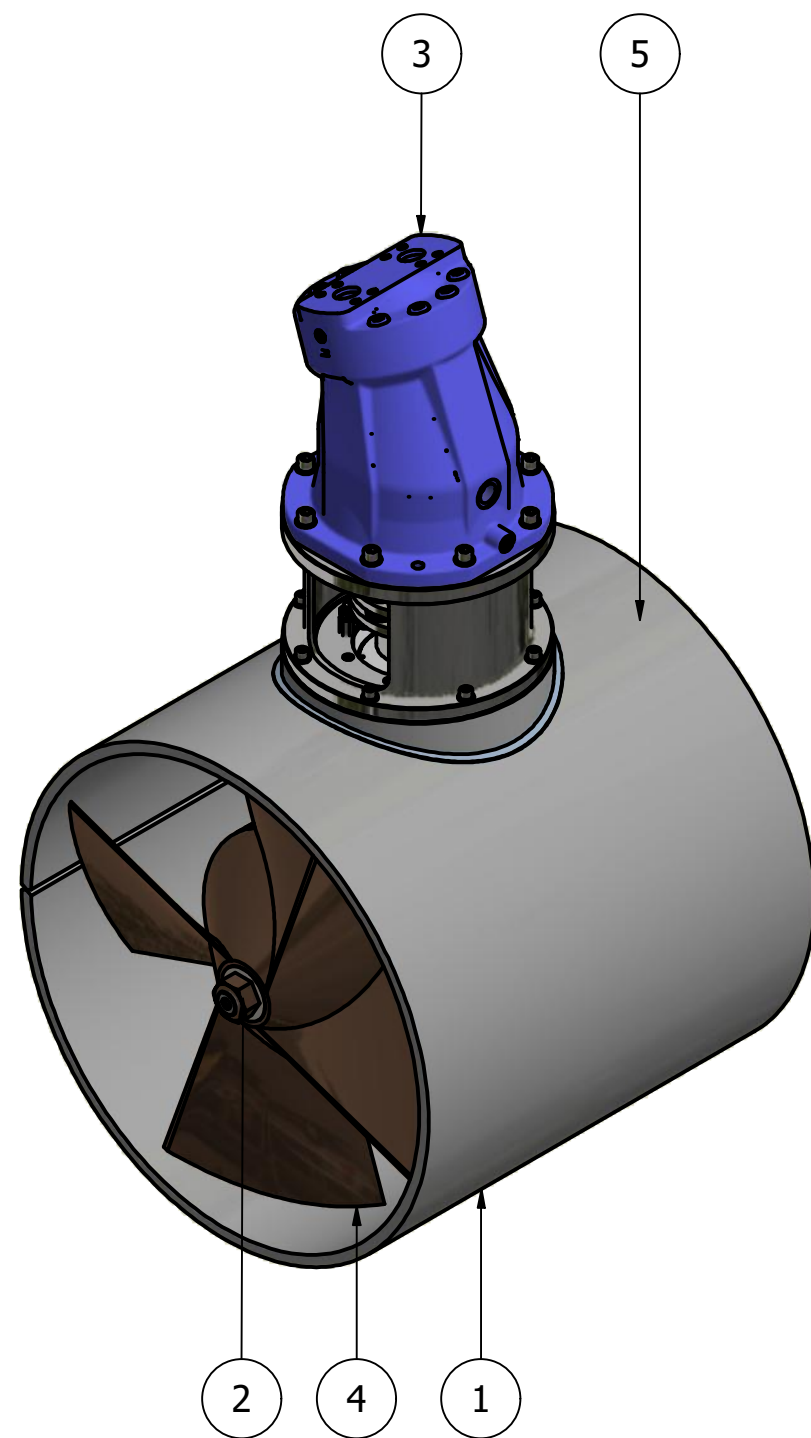

ITEM	QTY	PART NUMBER
1	1	TUNNEL ASSEMBLY
2	1	POD ASSEMBLY
3	1	MOTOR ASSEMBLY
4	1	PROPELLER 1
5	1	PROPELLER 2

NOMINAL PROP DIA	1000mm
POWER RANGE	252-393Kw (338-527hp)
MIN / MAX THRUST	2772-4323kgf (6111-9531lbf)
WEIGHT APPROXIMATELY (EXCL TUNNEL)	1259kg (2776lb)
STANDARD PRESSURE	330 BAR
NOMINAL FLOW	800 L/min

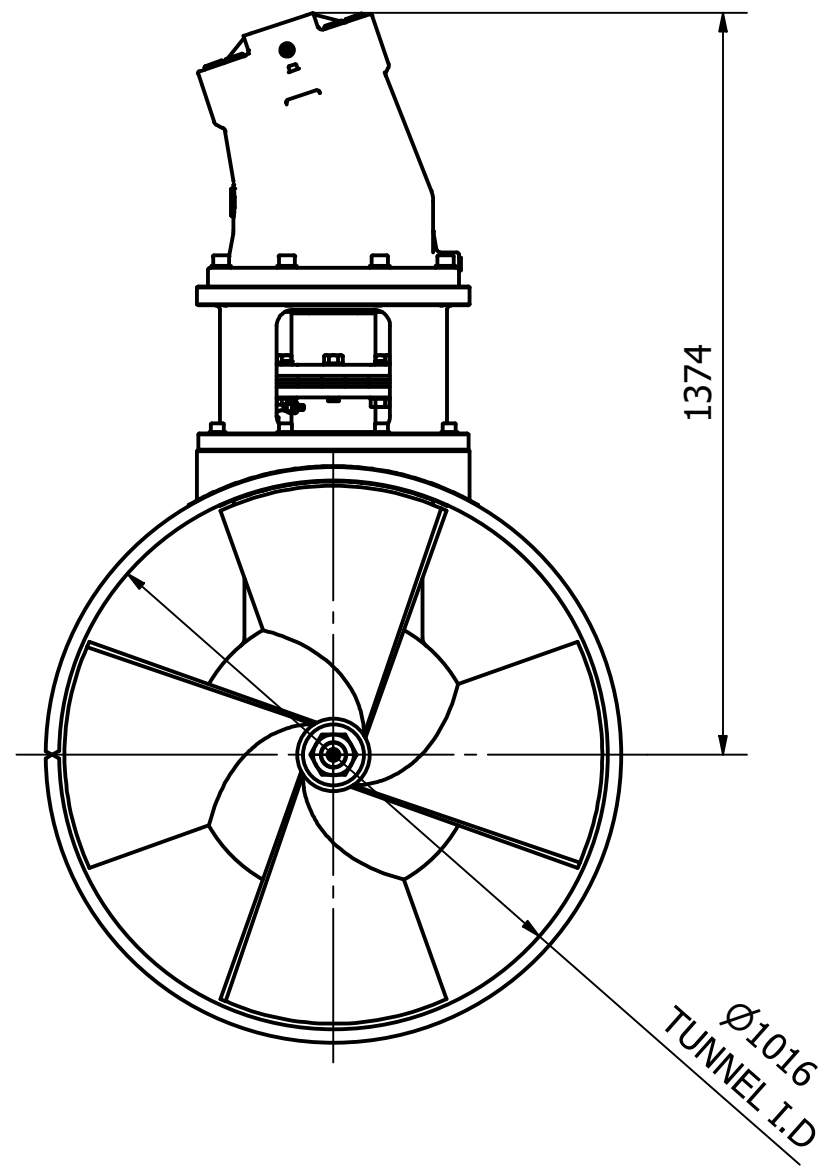
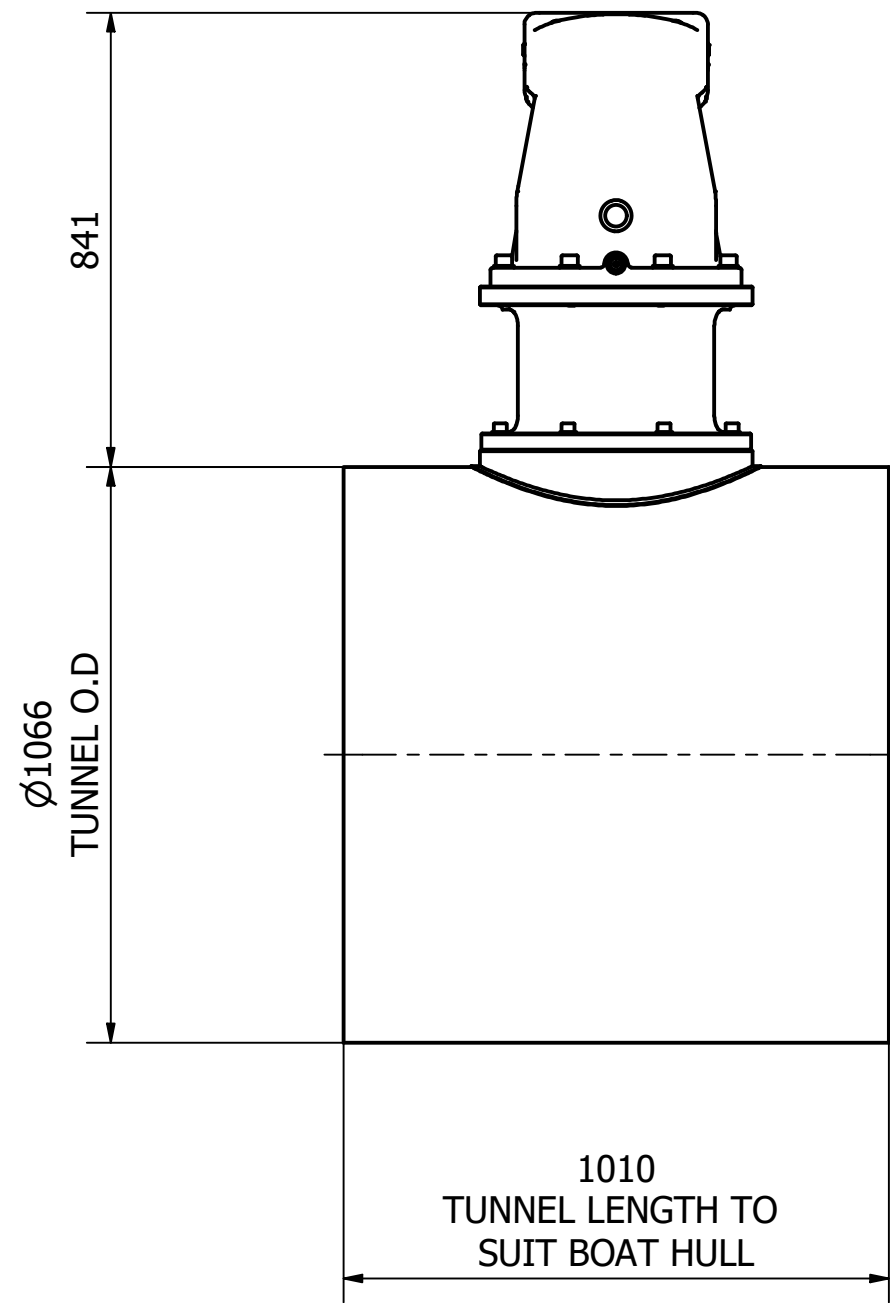

 <p><b>OCEAN MARINE SYSTEMS</b></p> <p>Tel: +44 (0)1202 596630 www.oceanmarinesystems.co.uk</p>	Title <b>TUNNEL THRUSTER - HYDRAULIC</b>		Revision <b>1</b>	Dimensions in millimeters & degrees Gen. Tolerance ± 0.2 Gen. Finish 3.2 ✓  <i>If in doubt ask!</i>
	Drawing No. <b>H-1000-T</b>	Material	Finish	
Sheet 1 of 1	Scale NTS @ A3	Mass N/A	Date Drawn 04/03/2020	By JG
			Modified Date	By
			Cert.	Insp.
				Grade