

ITEM	QTY	PART NUMBER
1	1	TUNNEL ASSEMBLY
2	1	POD ASSEMBLY
3	1	MOTOR ASSEMBLY
4	1	PROPELLER 1
5	1	PROPELLER 2

NOMINAL PROP DIA	800mm
POWER RANGE	194-252Kw (260-338hp)
MIN / MAX THRUST	2328-2772kgf (5132-6111lbf)
WEIGHT APPROXIMATELY (EXCL TUNNEL)	772kg (1702lb)
STANDARD PRESSURE	330 BAR
NOMINAL FLOW	505 L/min

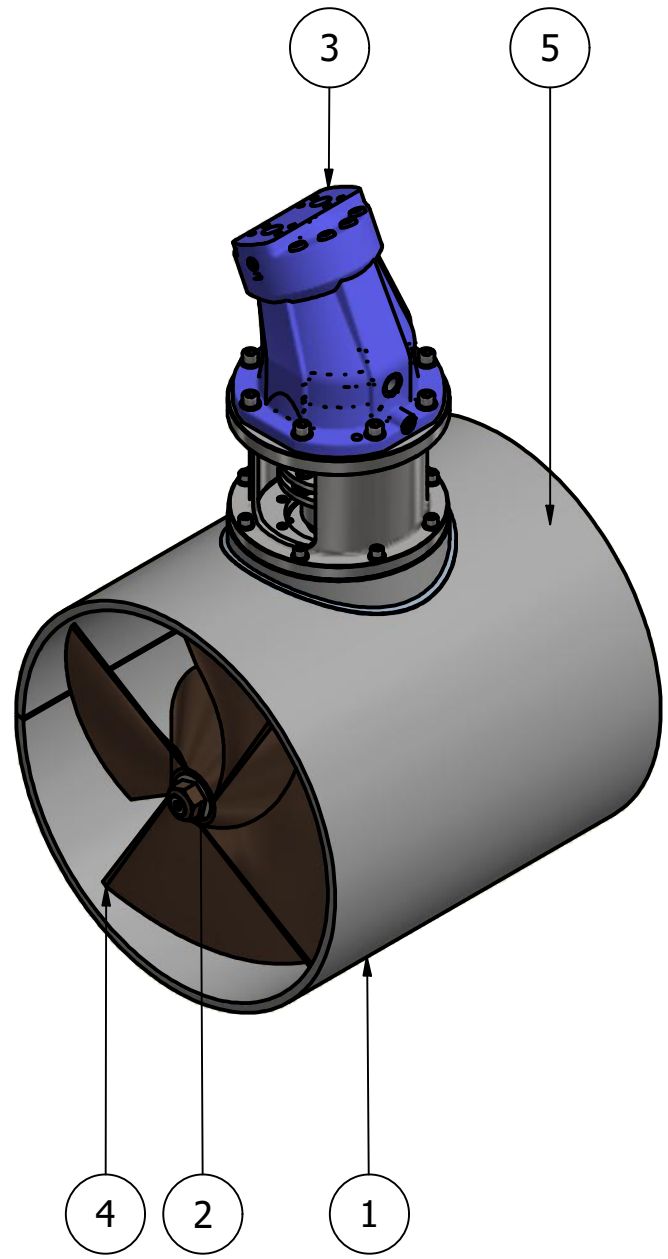
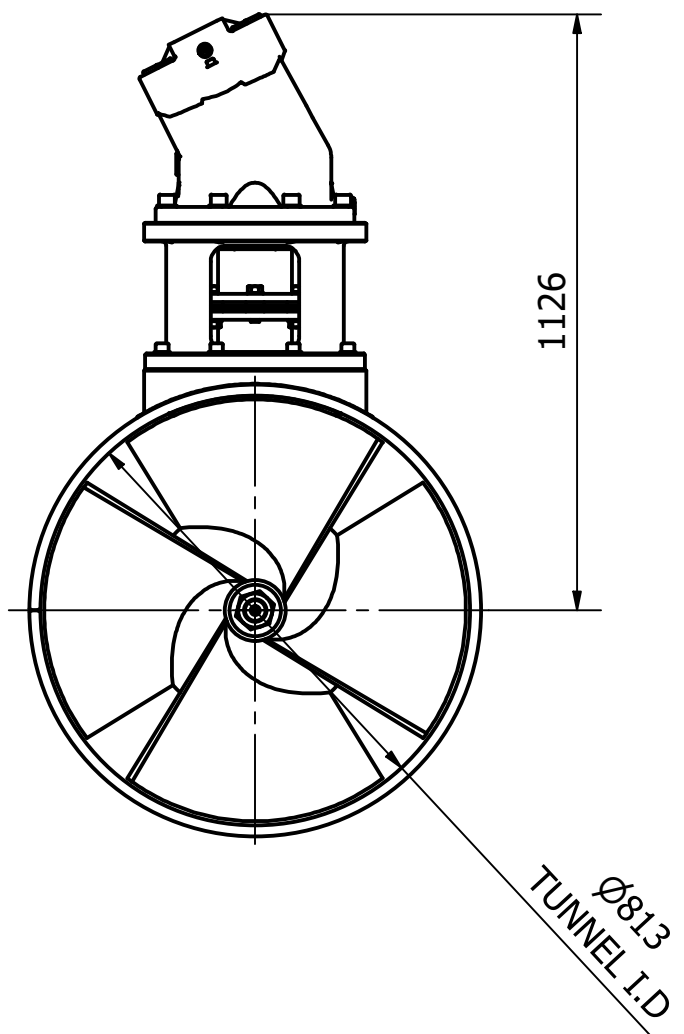
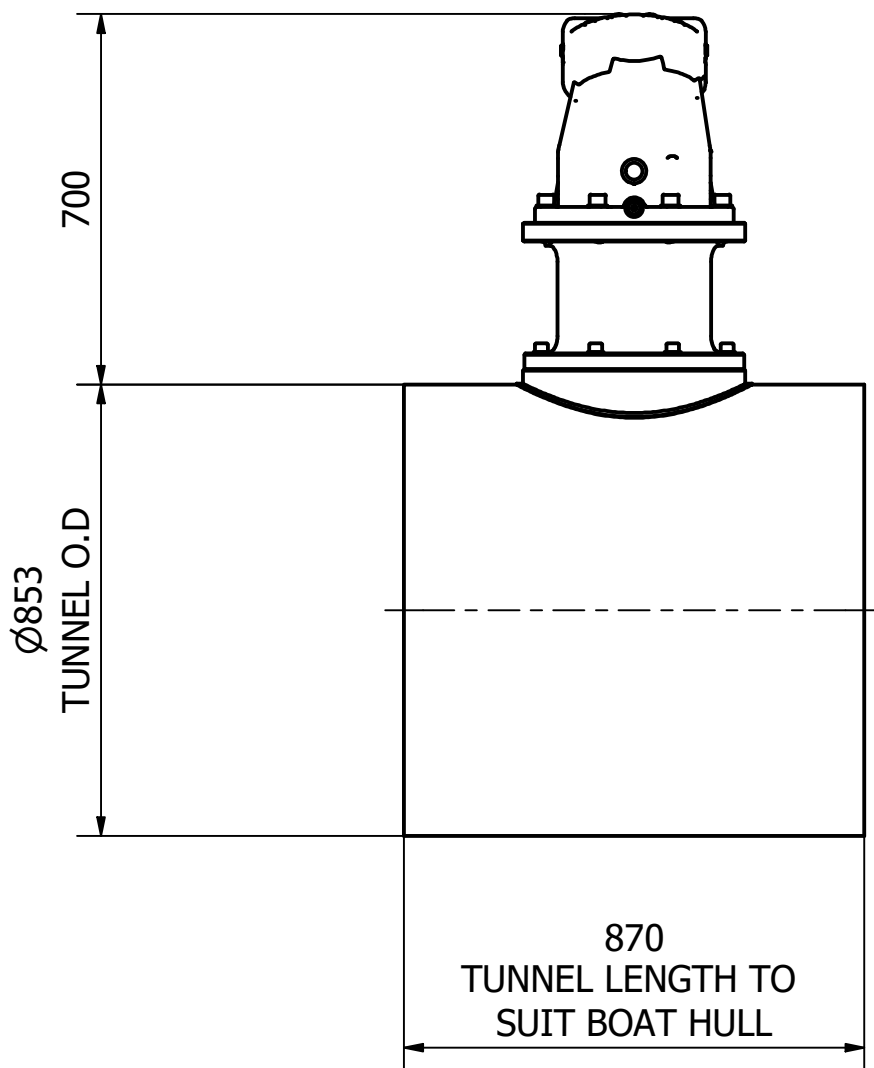

	Title TUNNEL THRUSTER - HYDRAULIC		Revision 1		Dimensions in millimeters & degrees											
	Drawing No. H-0800-T		Material		Finish		Gen. Tolerance ± 0.2	 <i>If in doubt ask!</i>								
Sheet 1 of 1		Scale NTS @ A3		Mass N/A		Date Drawn 03/03/2020			By JG		Modified Date		By		Cert.	Insp.