

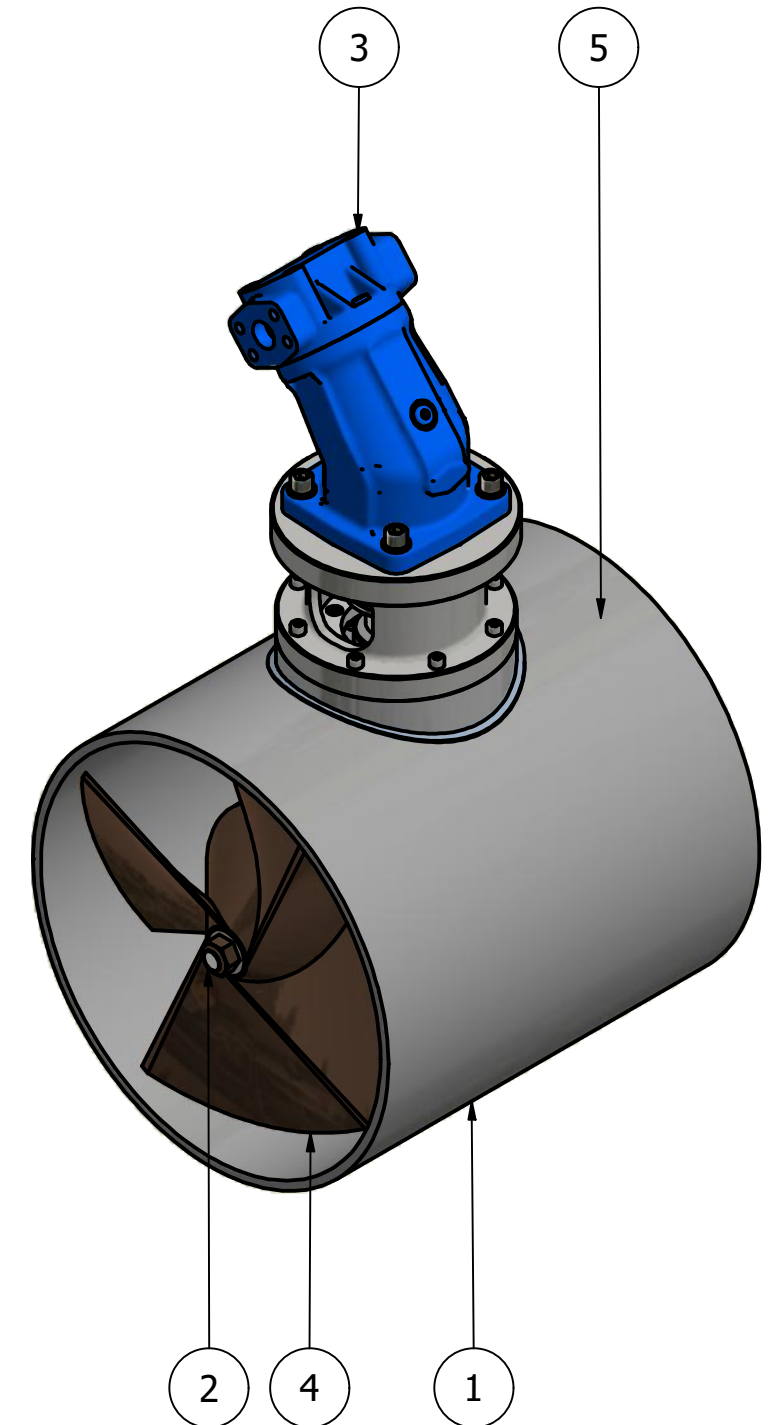

ITEM	QTY	PART NUMBER
1	1	TUNNEL ASSEMBLY
2	1	POD ASSEMBLY
3	1	MOTOR ASSEMBLY
4	1	PROPELLER 1
5	1	PROPELLER 2

NOMINAL PROP DIA	500mm
POWER RANGE	63-99Kw (85-133hp)
MIN / MAX THRUST	756-1188kgf (1667-2619lbf)
WEIGHT APPROXIMATELY (EXCL TUNNEL)	251kg (553lb)
STANDARD PRESSURE	305 BAR
NOMINAL FLOW	265 L/min

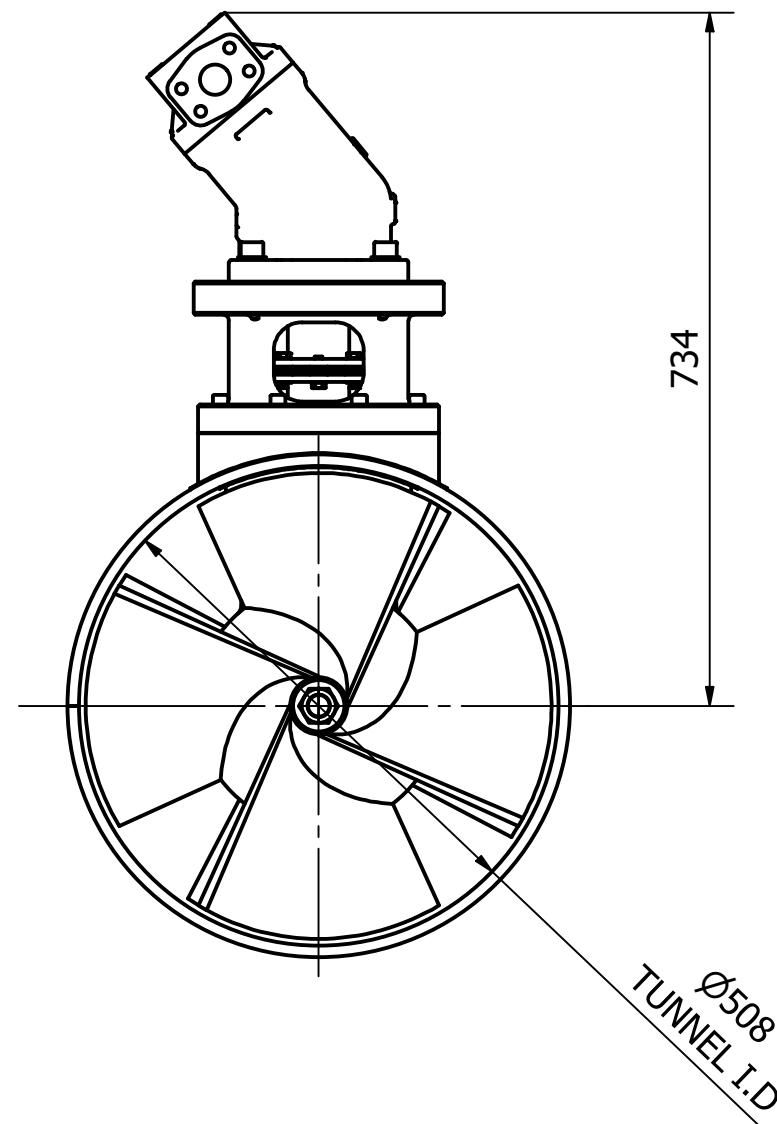
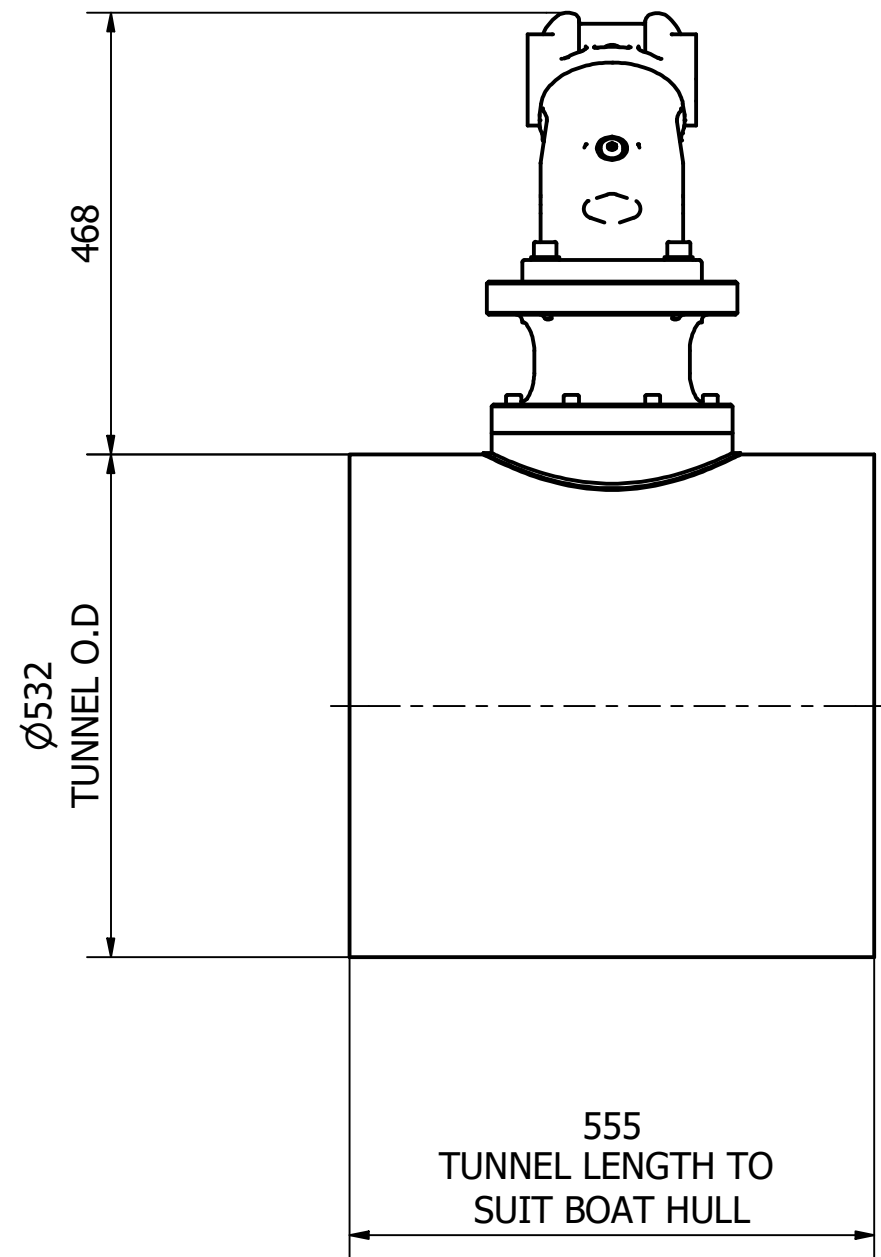

 <p>OCEAN MARINE SYSTEMS</p> <p>Tel: +44 (0)1202 596630 www.oceanmarinesystems.co.uk</p>	Title TUNNEL THRUSTER - HYDRAULIC		Revision 1	Dimensions in millimeters & degrees Gen. Tolerance ± 0.2 Gen. Finish 3.2 ✓			
	Drawing No. H-0500-T		Material	Finish	 If in doubt ask!		
Sheet 1 of 1	Scale NTS @ A3	Mass N/A	Date Drawn 03/03/2020	By JG	Modified Date	By	Cert. Insp. Grade