

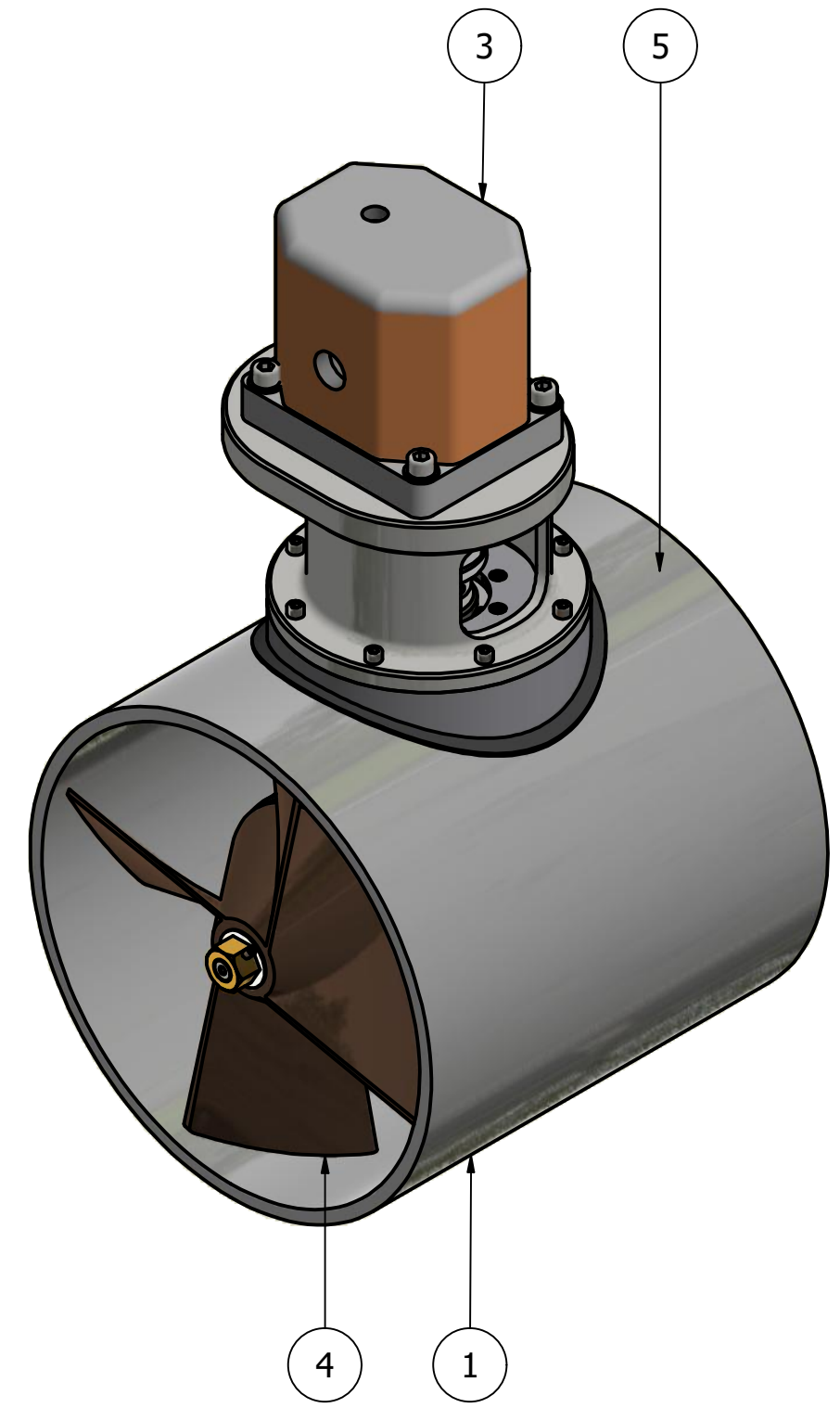

ITEM	QTY	PART NUMBER
1	1	TUNNEL ASSEMBLY
2	1	POD ASSEMBLY
3	1	MOTOR ASSEMBLY
4	1	PROPELLER 1
5	1	PROPELLER 1

NOMINAL PROP DIA	300mm
POWER RANGE	25-36Kw (34-48hp)
MIN / MAX THRUST	300-432kgf (661-952lbf)
WEIGHT APPROXIMATELY (EXCL TUNNEL)	47kg (104lb)
STANDARD PRESSURE	250 BAR
NOMINAL FLOW	98 L/min

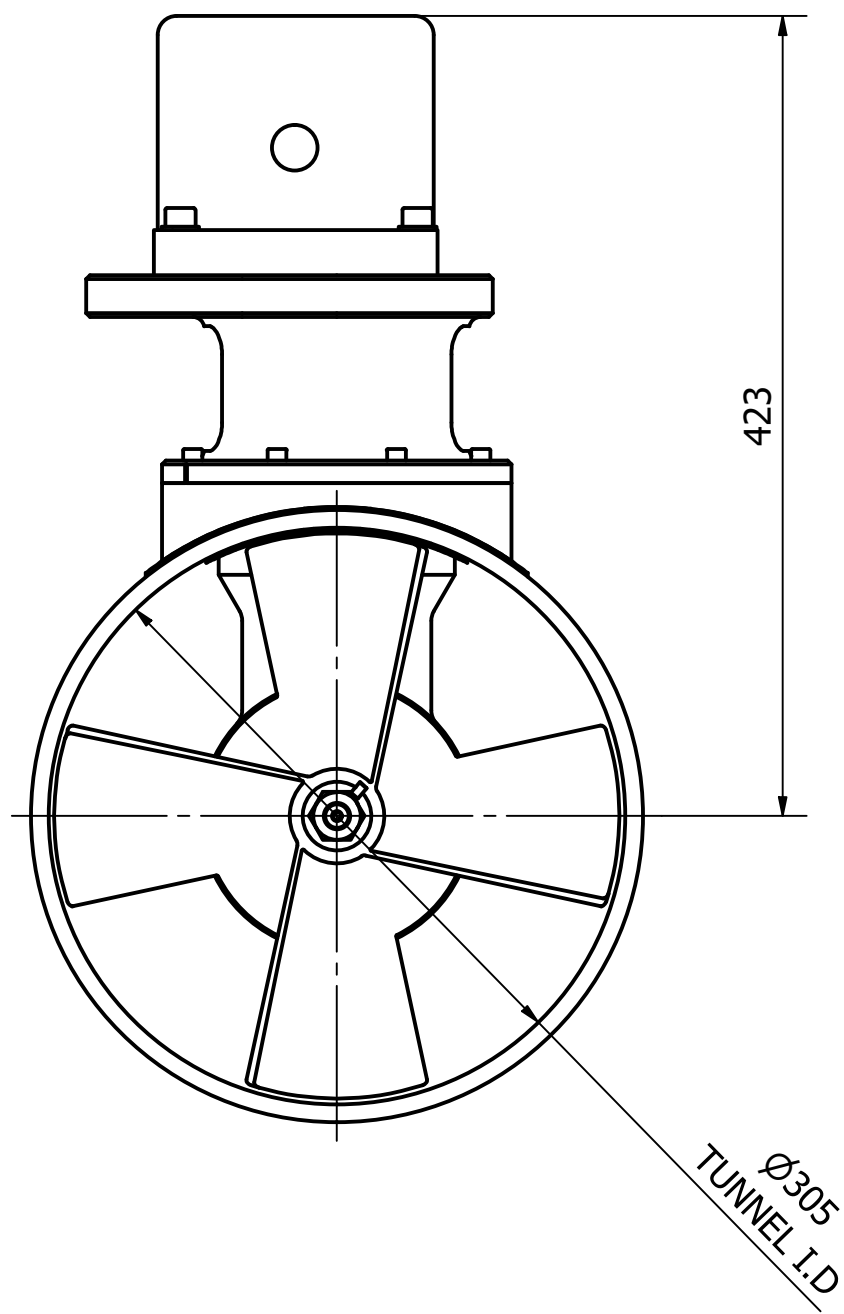
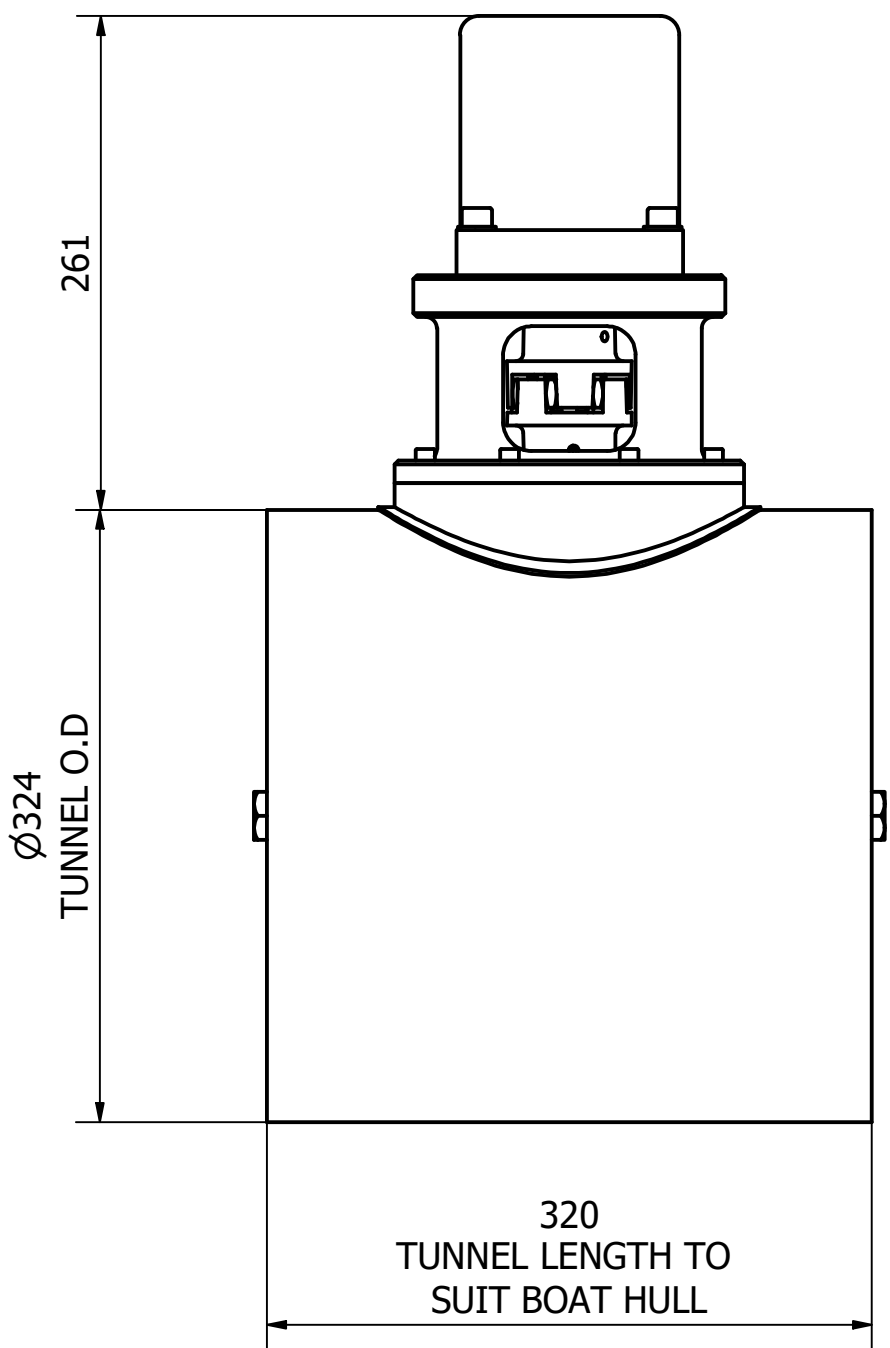

 <p>OCEAN MARINE SYSTEMS</p> <p>Tel: +44 (0)1202 596630 www.oceanmarinesystems.co.uk</p>	Title TUNNEL THRUSTER - HYDRAULIC		Revision 1	Dimensions in millimeters & degrees Gen. Tolerance ± 0.2 Gen. Finish 3.2 ✓  If in doubt ask!
	Drawing No. H-0300-T	Material	Finish	
Sheet 1 of 1 Scale NTS @ A3 Mass N/A Date Drawn 03/03/2020 By JG		Modified Date	By	Cert. Insp. Grade