

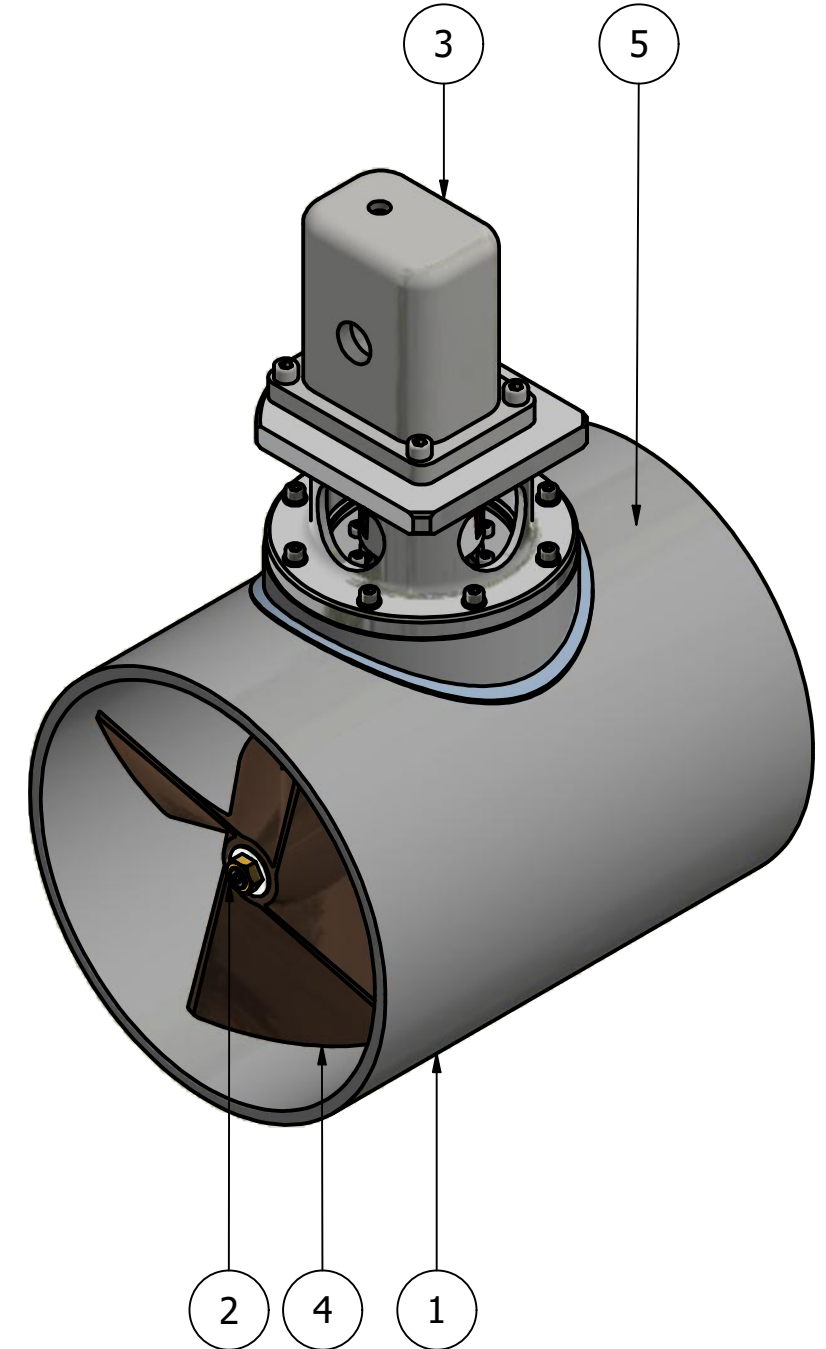

ITEM	QTY	DESCRIPTION
1	1	TUNNEL ASSEMBLY
2	1	POD ASSEMBLY
3	1	MOTOR ASSEMBLY
4	1	PROPELLER 1
5	1	PROPELLER 2

NOMINAL PROP DIA	250mm
POWER RANGE	7.5-25Kw (10-34hp)
MIN / MAX THRUST	92-300kgf (205-661lbf)
WEIGHT APPROXIMATELY (EXCL TUNNEL)	26kg (57lb)
STANDARD PRESSURE	250 BAR
NOMINAL FLOW	68 L/min

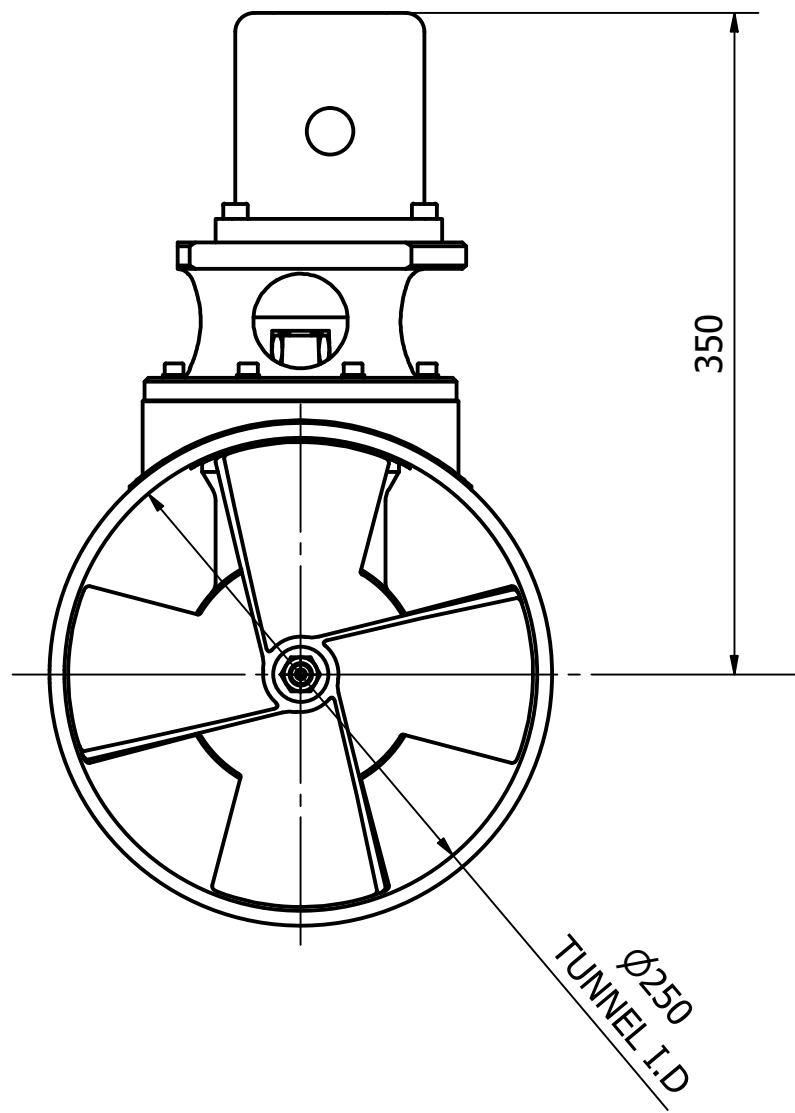
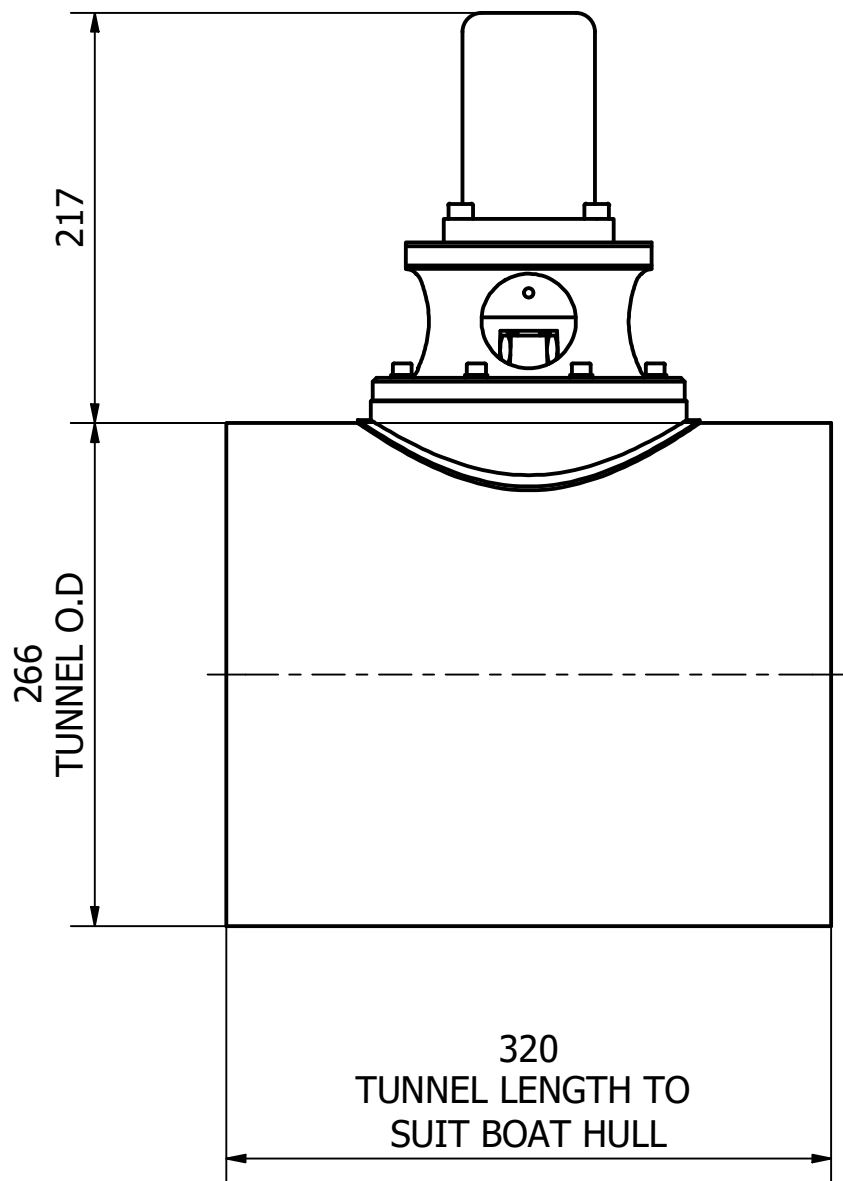

 <p>OCEAN MARINE SYSTEMS</p> <p>Tel: +44 (0)1202 596630 www.oceanmarinesystems.co.uk</p>	Title TUNNEL THRUSTER - HYDRAULIC		Revision 1	Dimensions in millimeters & degrees Gen. Tolerance ± 0.2 Gen. Finish 3.2 ✓  <i>If in doubt ask!</i>				
	Drawing No. H-0250-T		Material		Finish			
	Sheet 1 of 1	Scale NTS @ A3	Mass N/A		Date Drawn 03/03/2020	By JG	Modified Date	By
	Cert.		Insp.		Grade			