

ITEM	QTY	DESCRIPTION
1	1	ELECTRIC MAIN DRIVE MOTOR
2	1	ELECTRIC LIFT MECHANISM
3	1	TUNNEL ASSEMBLY
4	1	POD ASSEMBLY
5	1	PROPELLER 1
6	1	PROPELLER 2
7	2	PROXIMITY SESNOR

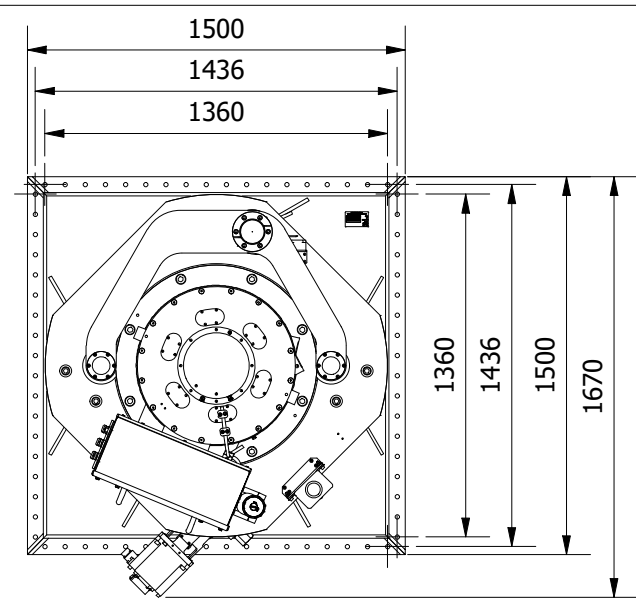

THIS THRUSTER REQUIRES A SUITABLY SIZED LIQUID COOLING SYSTEM FOR THE MAIN DRIVE MOTOR.

NOMINAL PROP DIA	1200 mm
POWER RANGE	394-565 kW (528-758 HP)
MIN / MAX THRUST	4693-6215 kgf (10346-13702 lbf)
WEIGHT APPROXIMATELY	4974 kg (10965 lb)

NOMINAL VLOTAGE : 500 AC

ALTERNATIVE MOTORS AND VOLTAGES AVAILABLE ON REQUEST

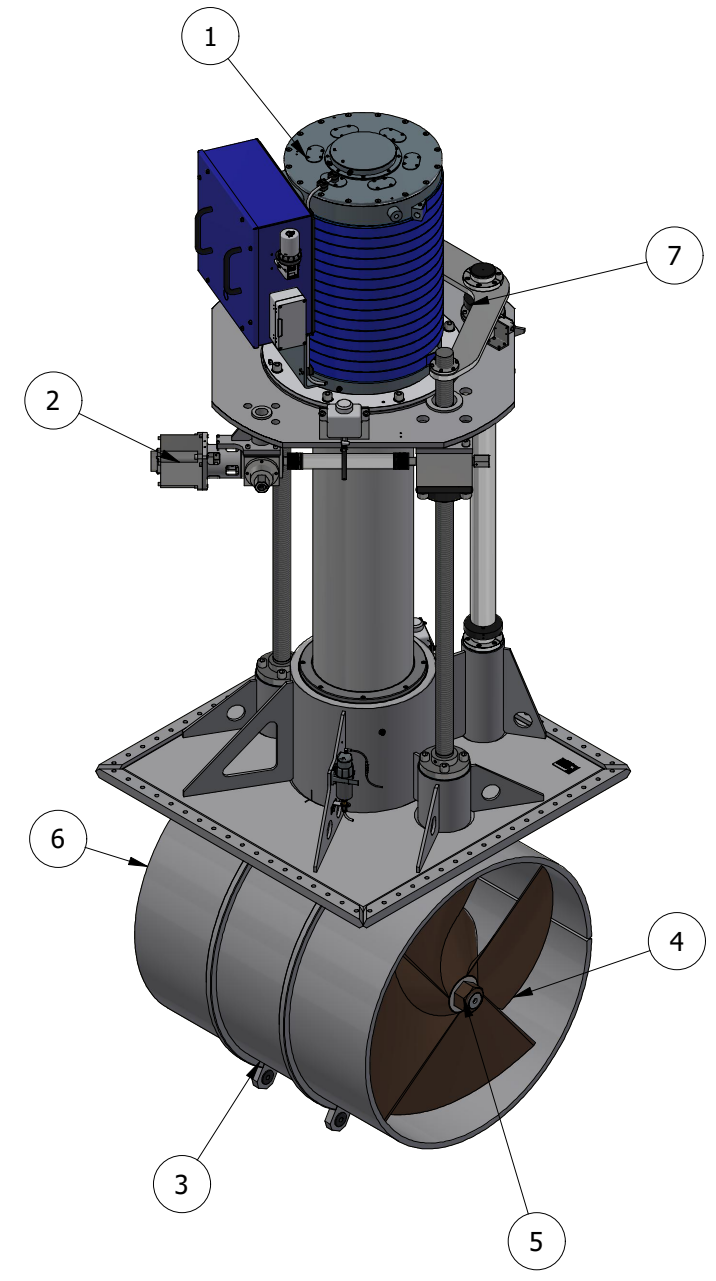
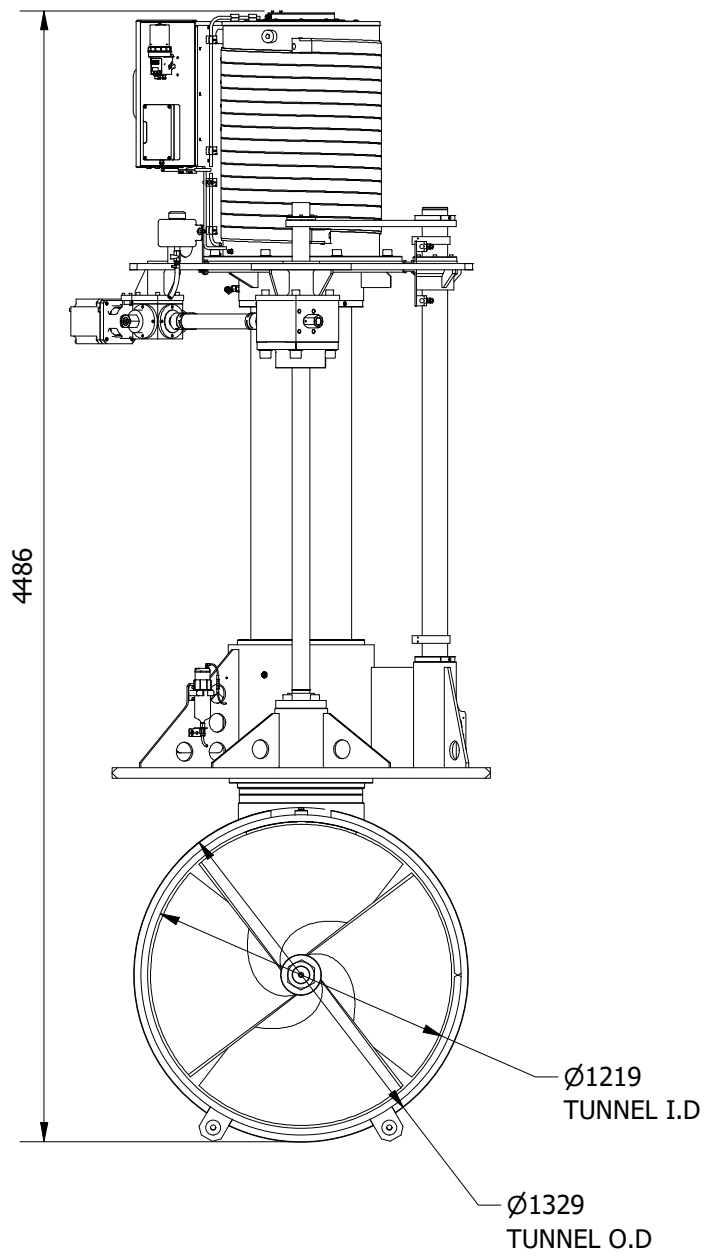
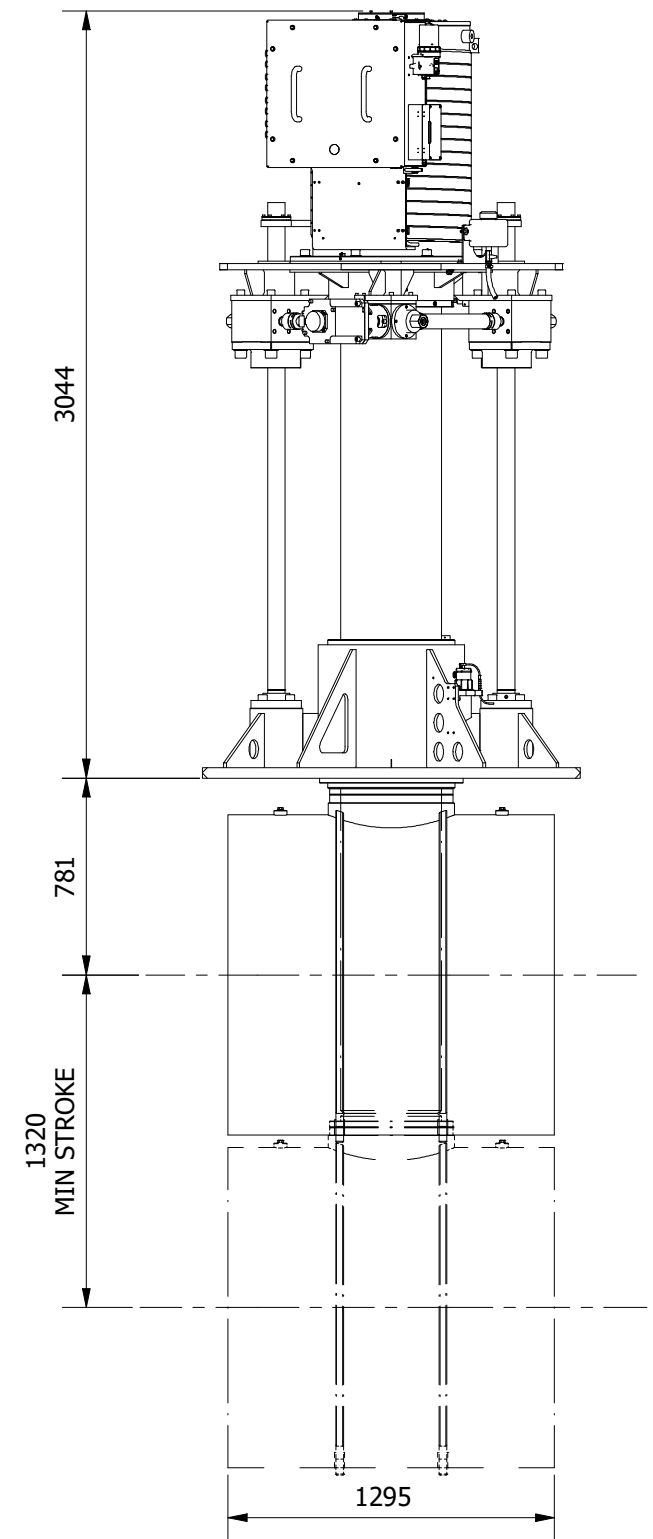

OMS
Ocean Marine Systems

Title VERTICAL RETRACTING THRUSTER - ELECTRIC		Revision 1
Drawing No. E-1200-V	Date Drawn 29/11/2021	By AL
Tel: +44 (0)1202 596630 www.oms.ltd		© Copyright. All rights to this drawing and design are the sole property of OMS Ltd. This drawing must not be copied, communicated or loaned to any third party without the written consent of OMS Ltd.