

| ITEM | QTY | DESCRIPTION |
|------|-----|---------------------------|
| 1 | 1 | ELECTRIC MAIN DRIVE MOTOR |
| 2 | 1 | ELECTRIC LIFT MECHANISM |
| 3 | 1 | TUNNEL ASSEMBLY |
| 4 | 1 | POD ASSEMBLY |
| 5 | 1 | PROPELLER 1 |
| 6 | 1 | PROPELLER 2 |
| 7 | 2 | PROXIMITY SENSOR |

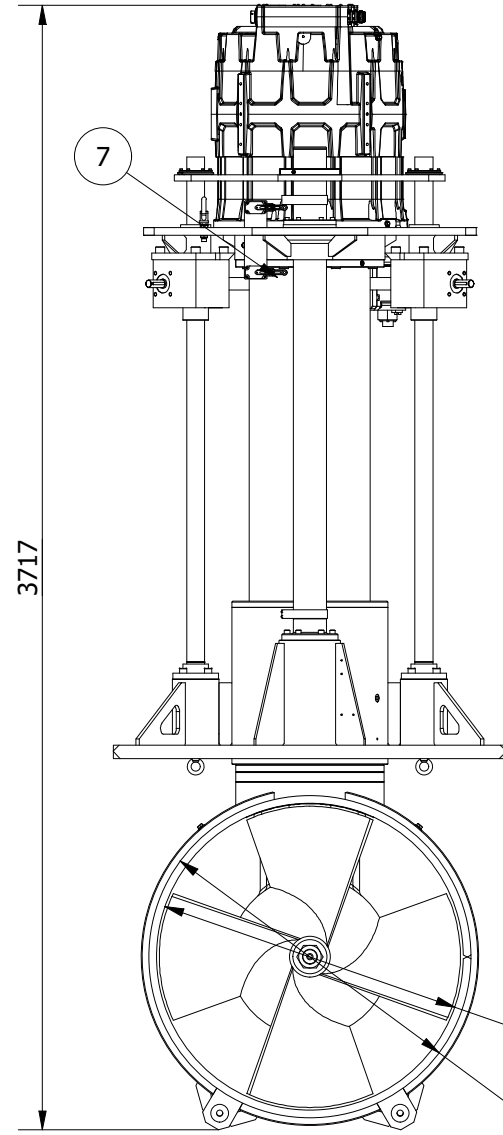
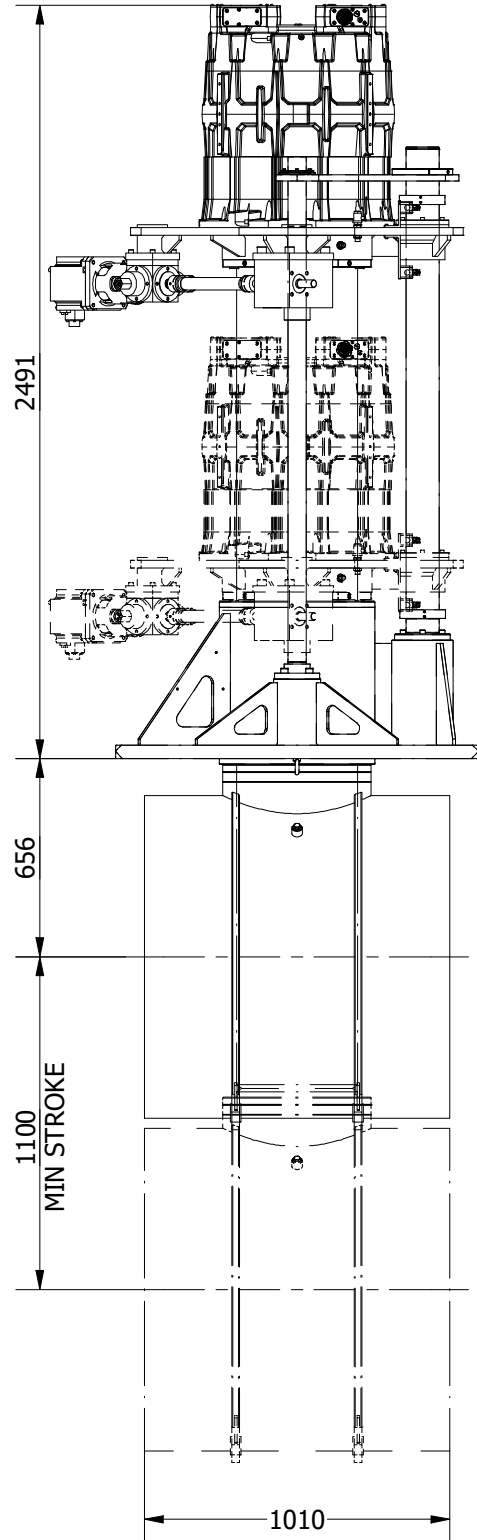
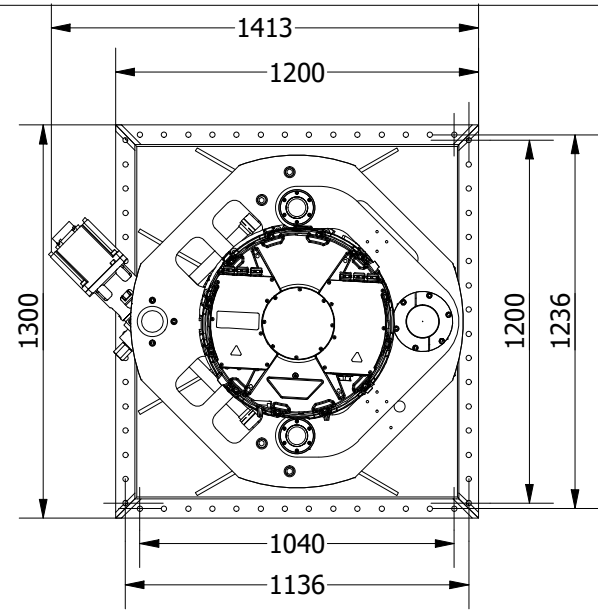

THIS THRUSTER REQUIRES A SUITABLY SIZED LIQUID COOLING SYSTEM FOR THE MAIN DRIVE MOTOR.

| | |
|----------------------|-----------------------------|
| NOMINAL PROP DIA | 1000mm |
| POWER RANGE | 252-393Kw (338-527hp) |
| MIN / MAX THRUST | 2772-4323kgf (6111-9506lbf) |
| WEIGHT APPROXIMATELY | 2760kg (6085lb) |

NOMINAL VOLTAGE : 500V AC
ALTERNATIVE MOTORS AND VOLTAGES AVAILABLE ON REQUEST.

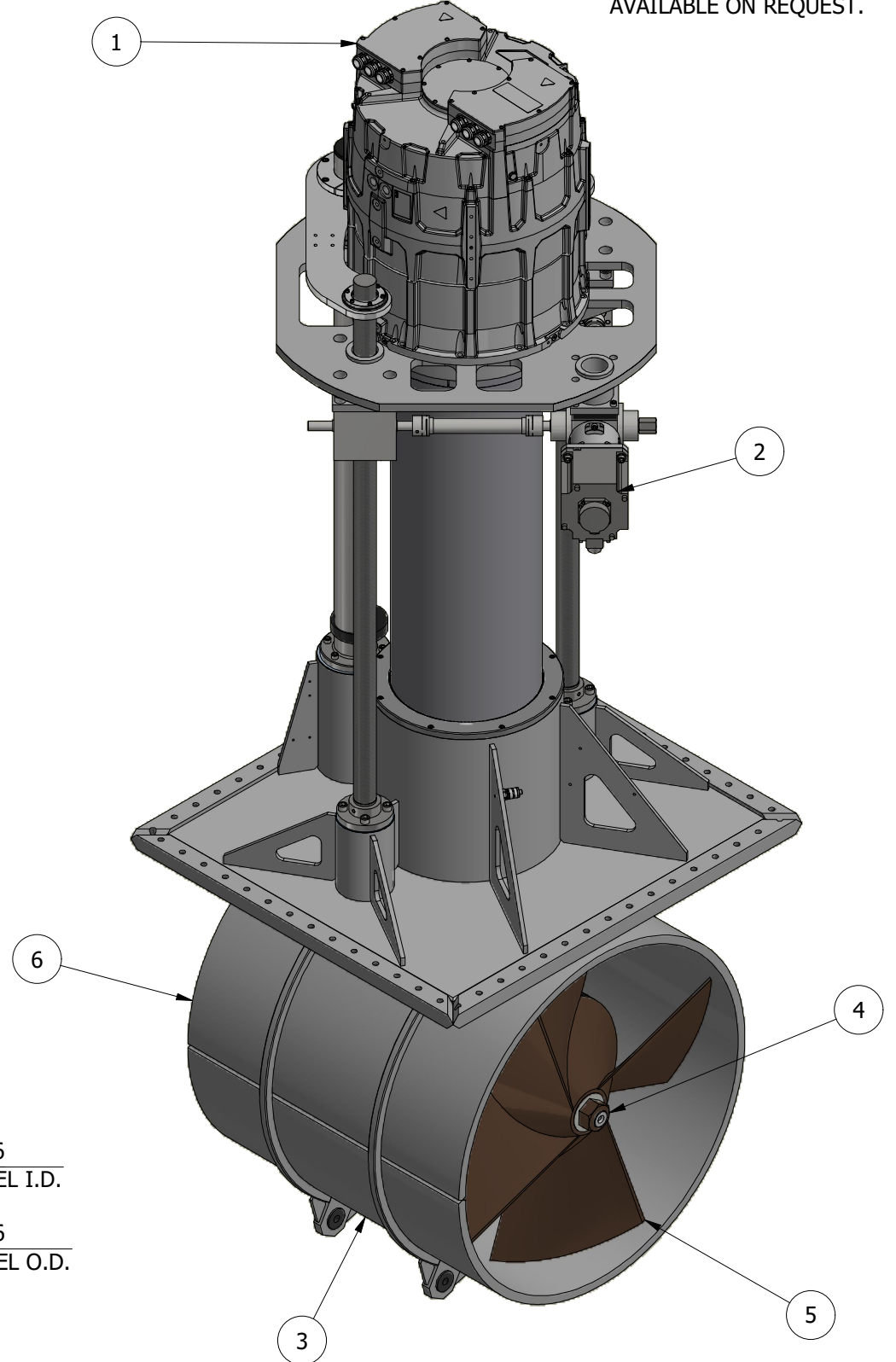

Ø1016
TUNNEL I.D.
Ø1066
TUNNEL O.D.

| | | | | | | | | | | |
|--|---|--------------------|-------------|--------------------------|--|-------------------------------------|----|------------|------------|-----------|
| | Title VERTICAL RETRACTING THRUSTER - ELECTRIC | | | | Revision 1 | Dimensions in millimeters & degrees | | | | |
| | Drawing No. E-1000-V | | Material | Finish | Gen. Tolerance ± 0.25 Gen. Finish 3.2 | | | | | |
| +44 (0)1202 596630 www.oms.ltd | Sheet 1 of 1 | Scale 1:25 @ A3 | Mass N/A | Date Drawn 12/05/2021 | By BG | Modified Date | By | Mat. Cert. | Insp. Lev. | Fin. Lev. |
| <p>© Copyright. All rights to this drawing and design are the sole property of OMS Ltd. This drawing must not be copied, communicated or loaned to any third party without the written consent of OMS Ltd.</p> | | | | | | | | | | |

If in doubt ask!