

| ITEM | QTY | DESCRIPTION |
|------|-----|-----------------|
| 1 | 1 | MOTOR ASSEMBLY |
| 2 | 1 | TUNNEL ASSEMBLY |
| 3 | 1 | POD ASSEMBLY |
| 4 | 1 | PROPELLER 1 |
| 5 | 1 | PROPELLER 2 |

| | |
|------------------------------------|-------------------------------|
| NOMINAL PROP DIA | 1000mm |
| POWER RANGE | 252-393 kW (338-527 hp) |
| MIN / MAX THRUST | 2772-4323 kgf (6111-9506 lbf) |
| WEIGHT APPROXIMATELY (EXCL TUNNEL) | 3015 kg (6648 lb) |

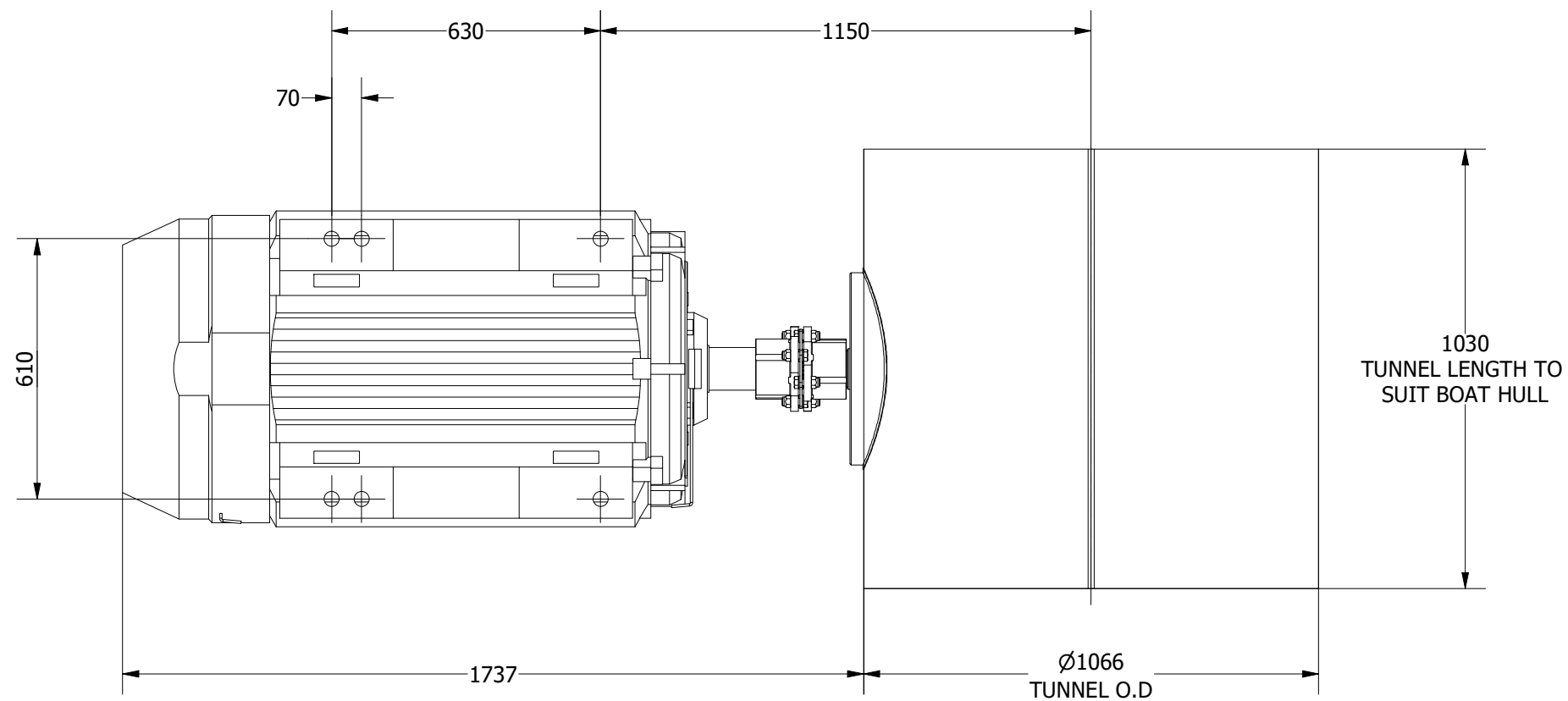
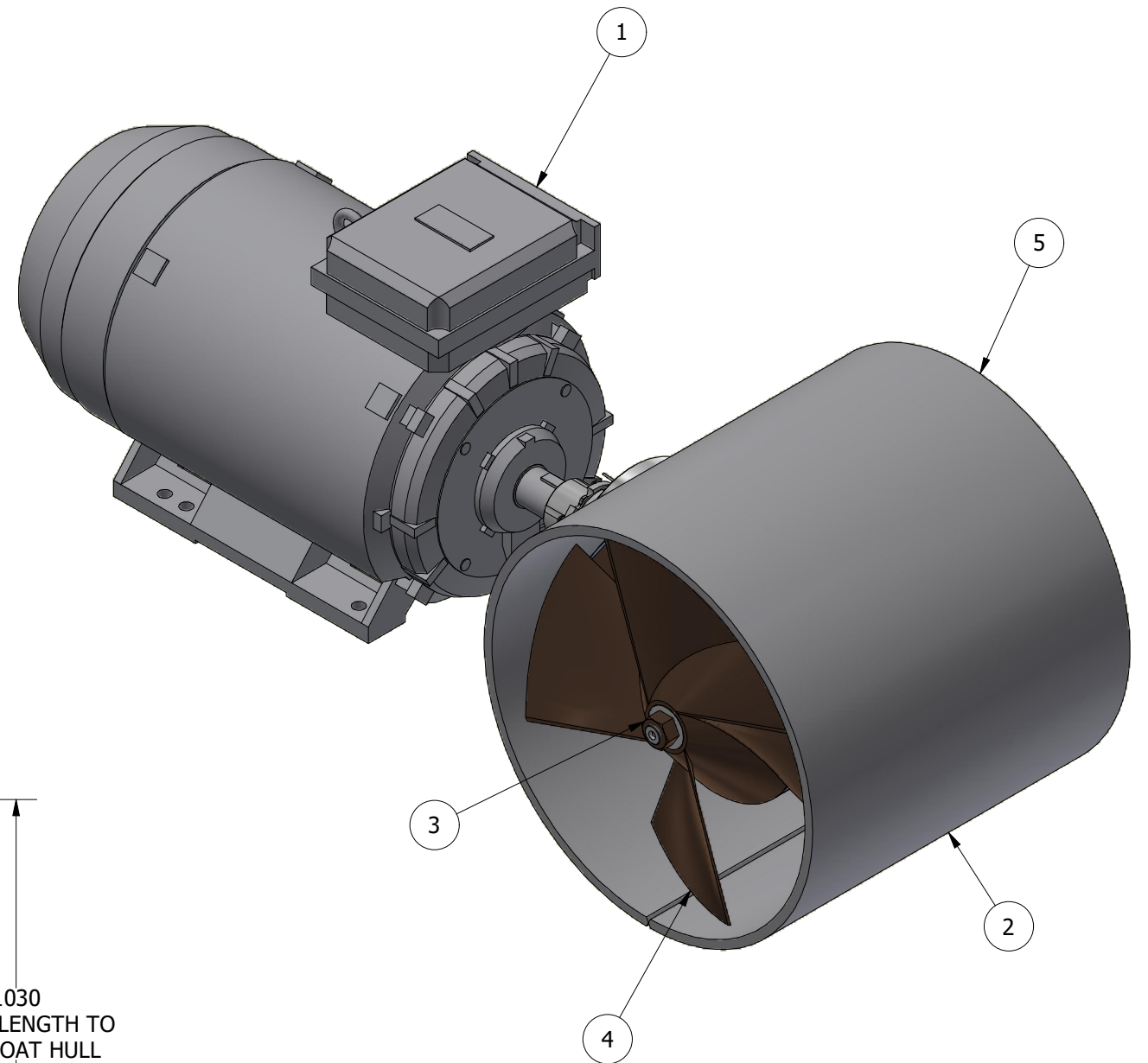
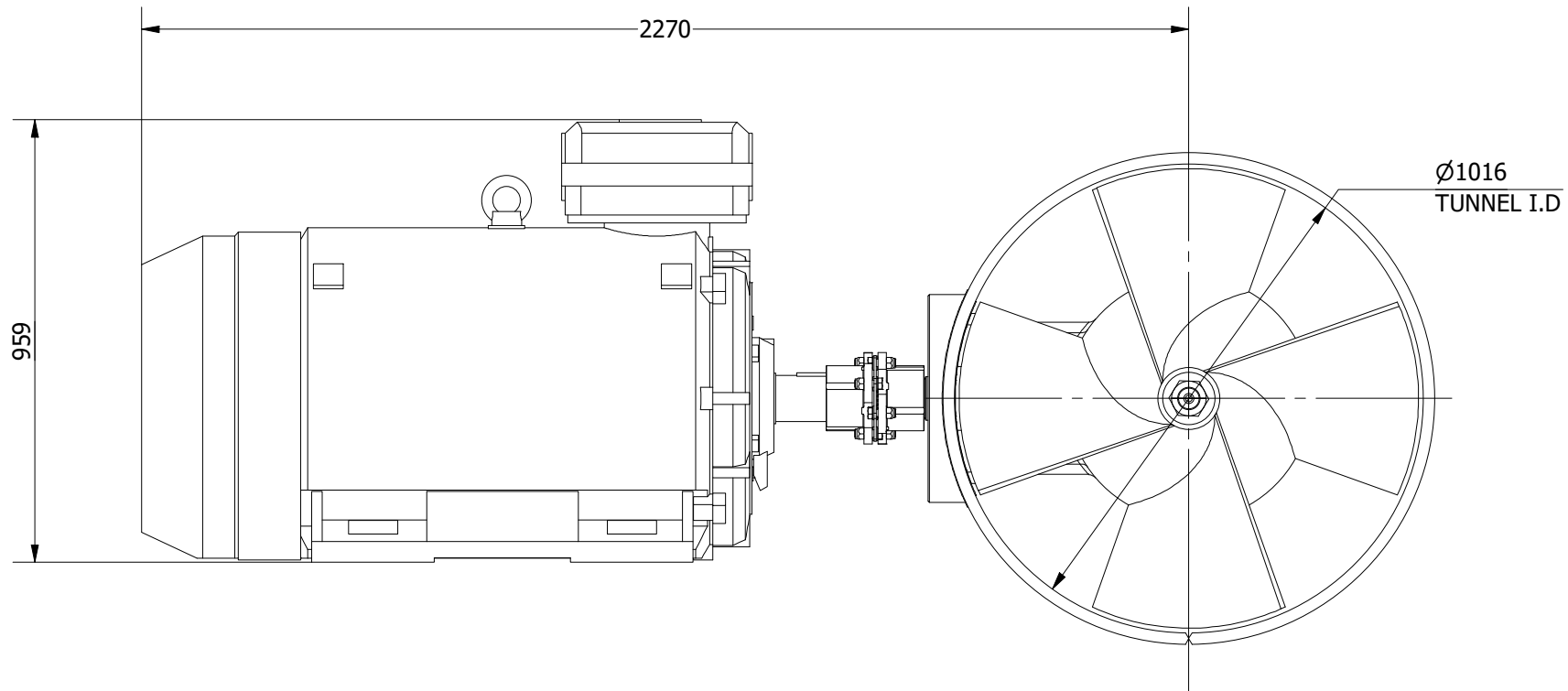

| | | |
|--|---|---------------|
| Title TUNNEL THRUSTER - ELECTRIC | | Revision 3 |
| Drawing No. E-1000-T | Date Drawn 07/03/2022 | By AL |
| Tel: +44 (0)1202 596630 www.oms.ltd | © Copyright. All rights to this drawing and design are the sole property of OMS Ltd. This drawing must not be copied, communicated or loaned to any third party without the written consent of OMS Ltd. | |