

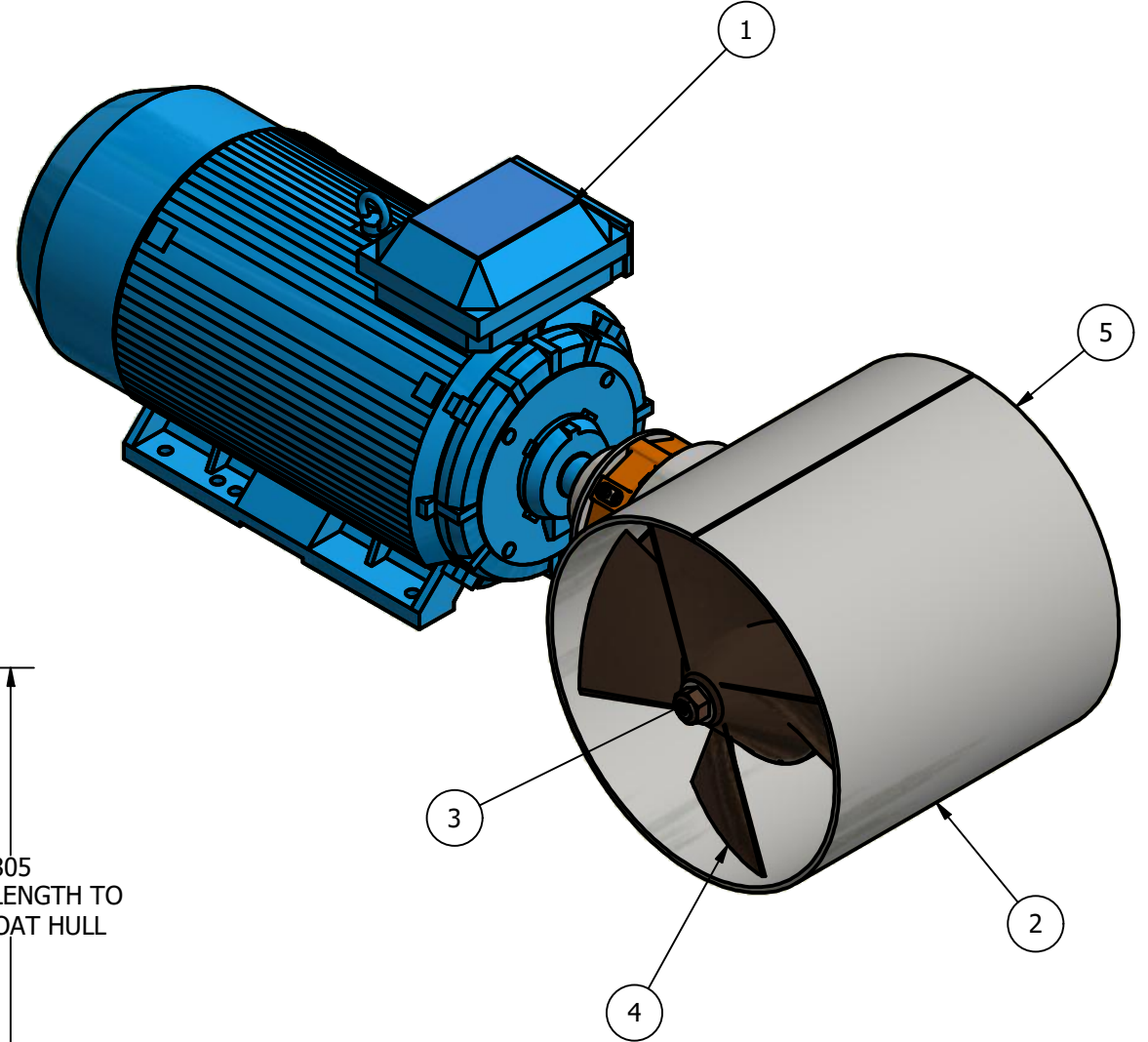

ITEM	QTY	DESCRIPTION
1	1	MOTOR ASSEMBLY
2	1	TUNNEL ASSEMBLY
3	1	POD ASSEMBLY
4	1	PROPELLER 1
5	1	PROPELLER 2

NOMINAL PROP DIA	800mm
POWER RANGE	194-252kw (260-338hp)
MIN / MAX THRUST	2328-2772kgf (5132-6111lbf)
WEIGHT APPROXIMATELY (EXCL TUNNEL)	2093kg (4615lb)

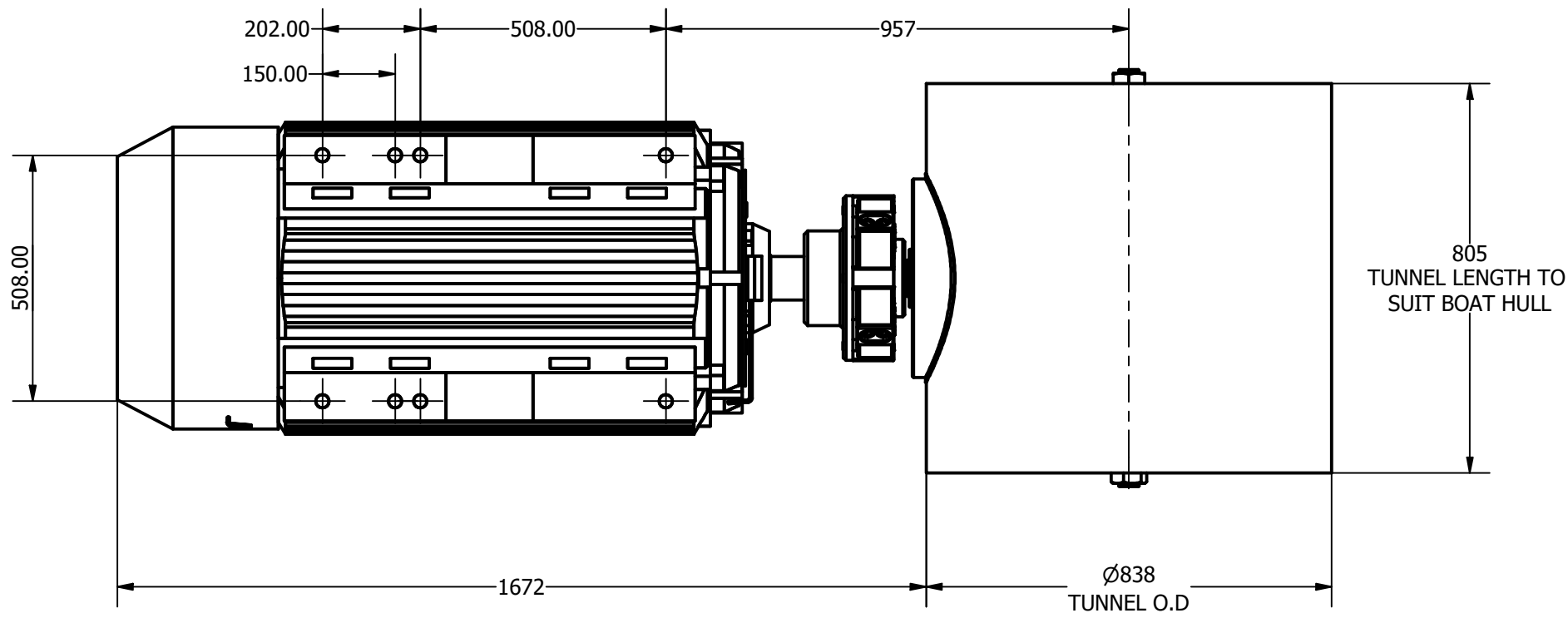
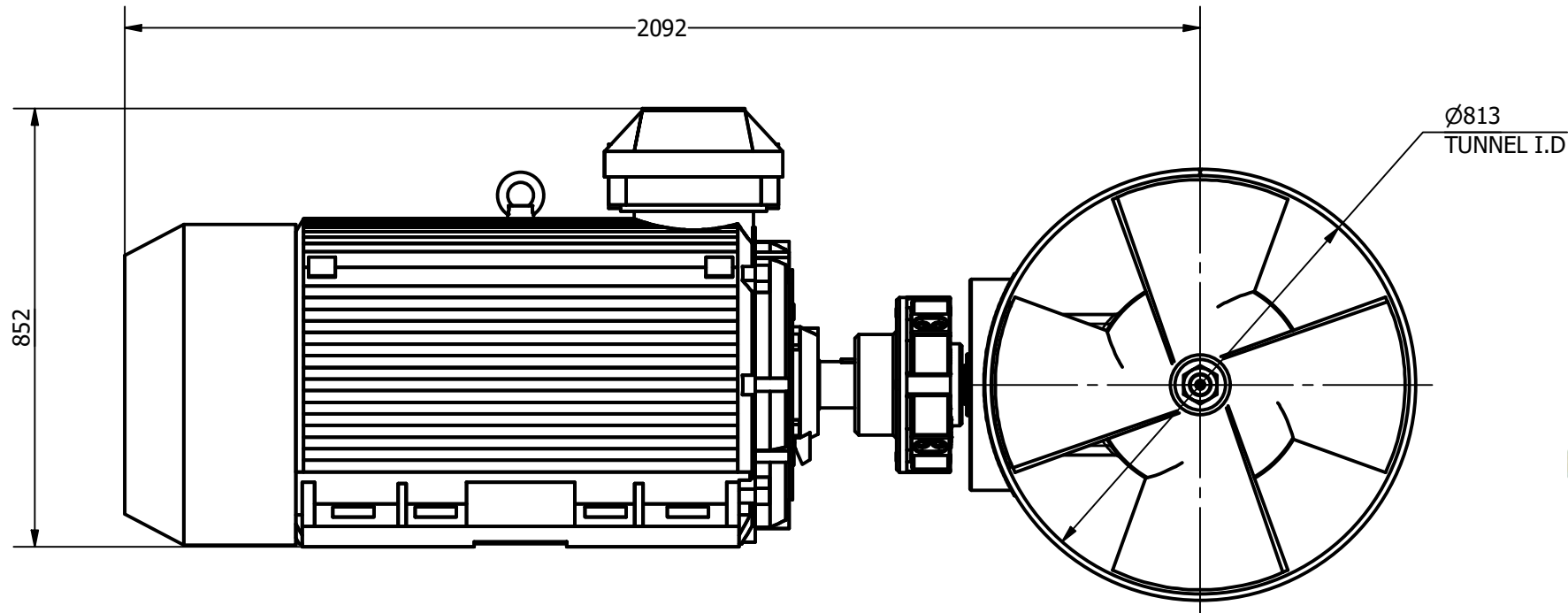

 <p>OCEAN MARINE SYSTEMS</p> <p>Tel: +44 (0)1202 596630 www.oceanmarinesystems.co.uk</p>	<p>Title: TUNNEL THRUSTER - ELECTRIC</p>		<p>Revision: 2</p>	<p>Dimensions in millimeters & degrees</p> <p>Gen. Tolerance ± 0.2</p> <p>Gen. Finish 3.2</p>
	<p>Drawing No.: E-0800-T</p>	<p>Material:</p>	<p>Finish:</p>	<p>Material Symbol</p> <p><i>If in doubt ask!</i></p>
<p>Sheet: 1 of 1</p>	<p>Scale: N.T.S @ A3</p>	<p>Mass: N/A</p>	<p>Date Drawn: 02/02/2016</p> <p>By: LR</p>	<p>Modified Date: 28/01/2021</p> <p>By: BW</p>
<p>© Copyright. All rights to this drawing and design are the sole property of Ocean Marine Systems Ltd. This drawing must not be copied, communicated or loaned to any third party without the written consent of Ocean Marine Systems Ltd.</p>				