

ITEM	QTY	DESCRIPTION
1	1	MOUNTING BASE ASSEMBLY
2	1	LIFT PLATE ASSEMBLY
3	1	RETRACT TUBE ASSEMBLY
4	1	LIFTING SCREW ASSEMBLY
5	1	MOTOR ASSEMBLY
6	1	TUNNEL ASSEMBLY
7	1	POD ASSEMBLY
8	1	PROPELLER 1
9	1	PROPELLER 2
10	2	PROXIMITY SENSOR

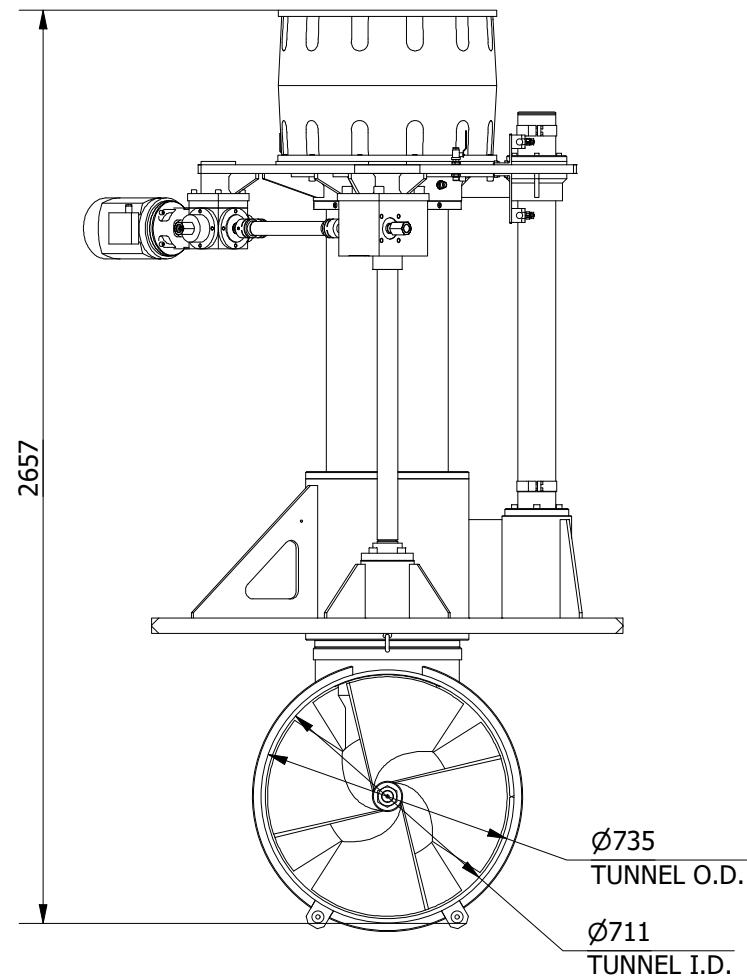

THIS THRUSTER REQUIRES A SUITABLY SIZED LIQUID COOLING SYSTEM FOR THE MAIN DRIVE MOTOR.

NOMINAL PROP DIA	700mm
POWER RANGE	142-194kw (190-260hp)
MIN / MAX THRUST	1704-2328kgf (3757-5132lbf)
WEIGHT APPROXIMATELY	1713kg (3776lb)

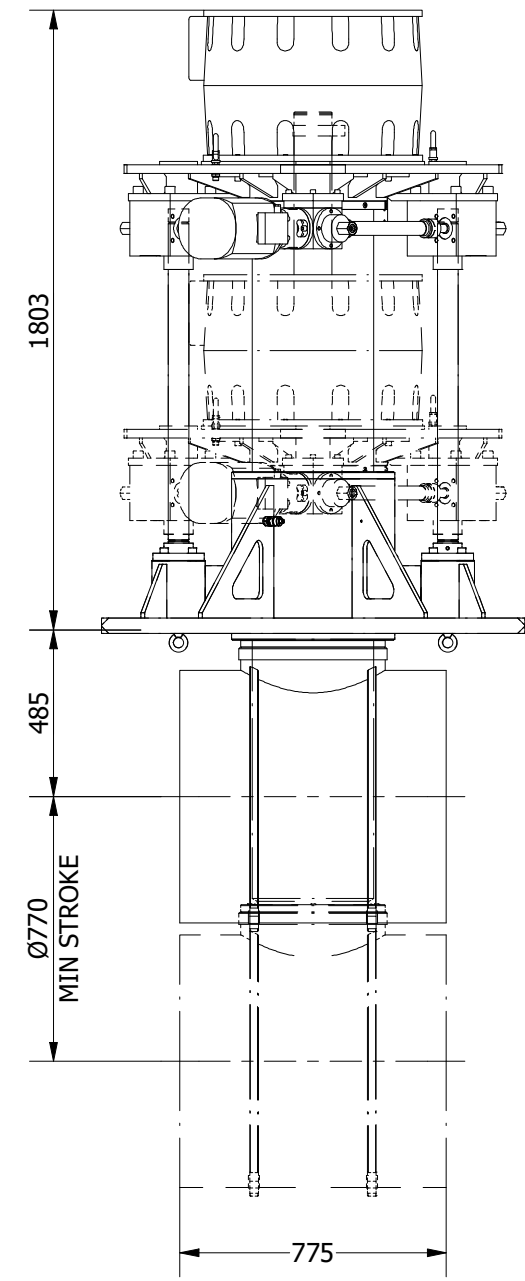
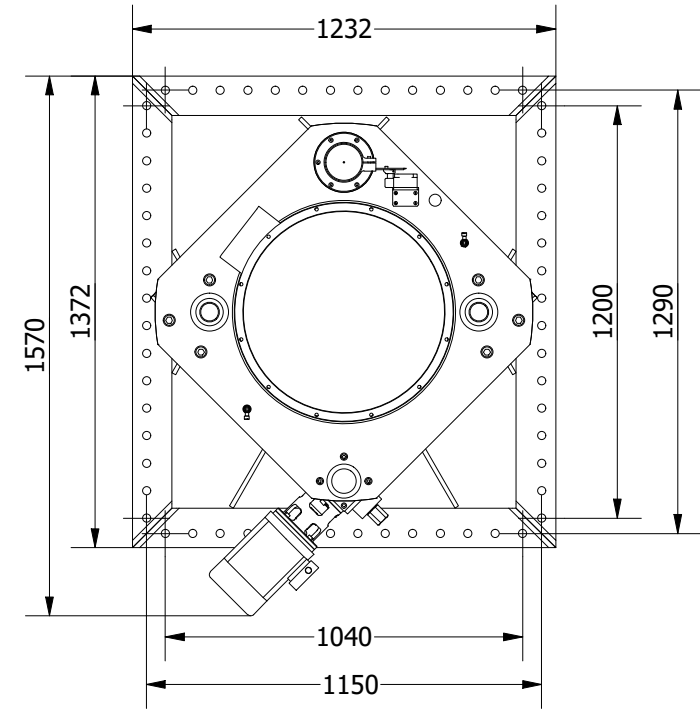
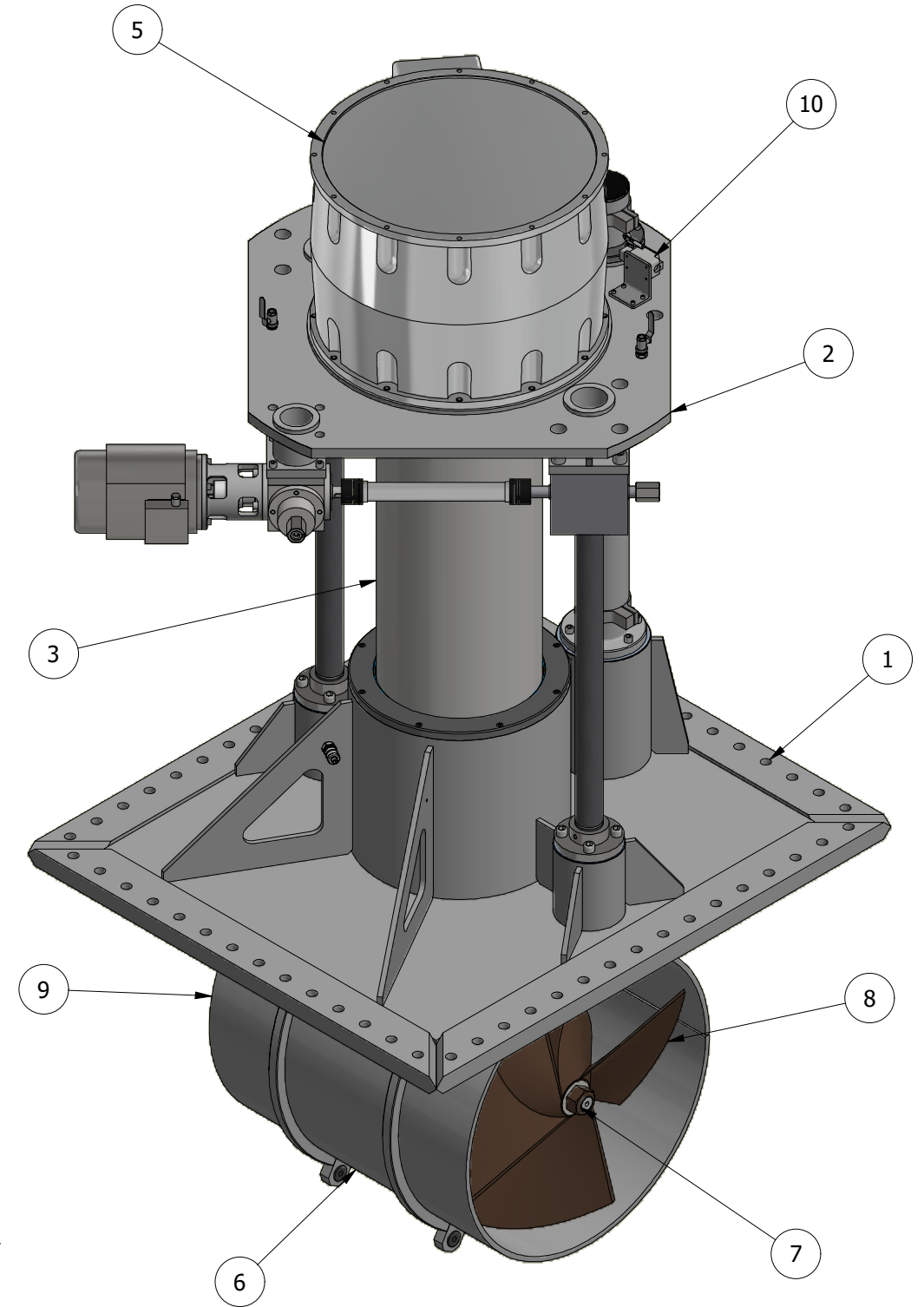

OMS
Ocean Marine Systems

Title ELECTRICAL VERTIVAL RETRACTING THRUSTER		Revision 1
Drawing No. E-0700-V		Date Drawn By 06/08/2015 LR
Tel: +44 (0)1202 596630 www.oms.ltd		© Copyright. All rights to this drawing and design are the sole property of OMS Ltd. This drawing must not be copied, communicated or loaned to any third party without the written consent of OMS Ltd.