

ITEM	QTY	DESCRIPTION
1	1	MOUNTING BASE ASSEMBLY
2	1	LIFT PLATE ASSEMBLY
3	1	RETRACT TUBE ASSEMBLY
4	1	LIFTING SCREW ASSEMBLY
5	1	ROTATING DRIVE ASSEMBLY
6	1	MOTOR ASSEMBLY
7	1	TUNNEL ASSEMBLY
8	1	POD ASSEMBLY
9	1	PROPELLER 1
10	1	PROPELLER 2
11	2	PROXIMITY SENSOR LIFT MECHANISM
12	1	PROXIMITY SENSOR ROTATING MECHANISM

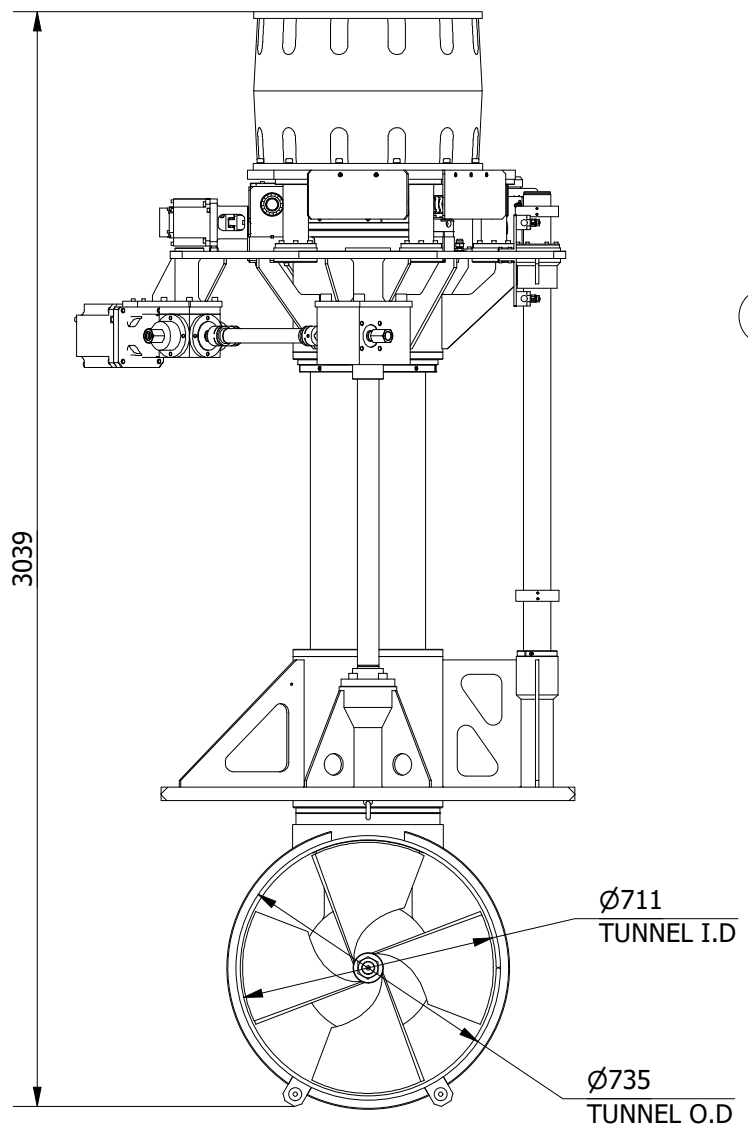

THIS THRUSTER REQUIRES A SUITABLY SIZED LIQUID COOLING SYSTEM FOR THE MAIN DRIVE MOTOR.

NOMINAL PROP DIA	700mm
POWER RANGE	142-194kw (190-260hp)
MIN / MAX THRUST	1704-2328kgf (3757-5132lbf)
WEIGHT APPROXIMATELY	1638kg (3612lb)

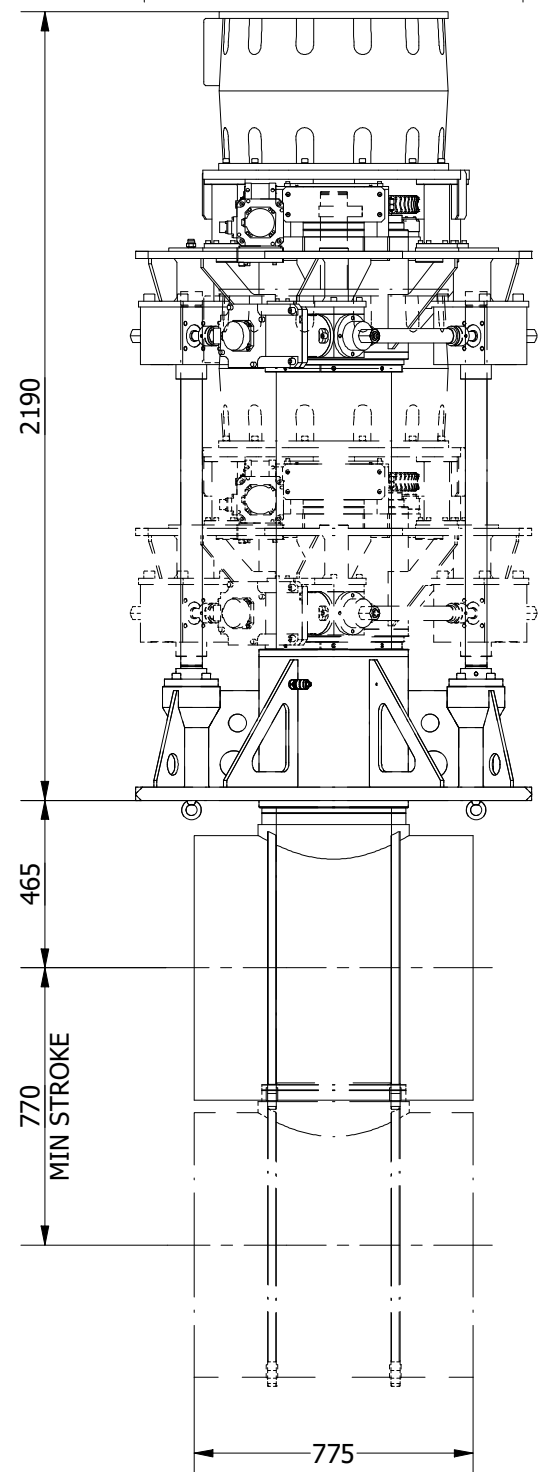
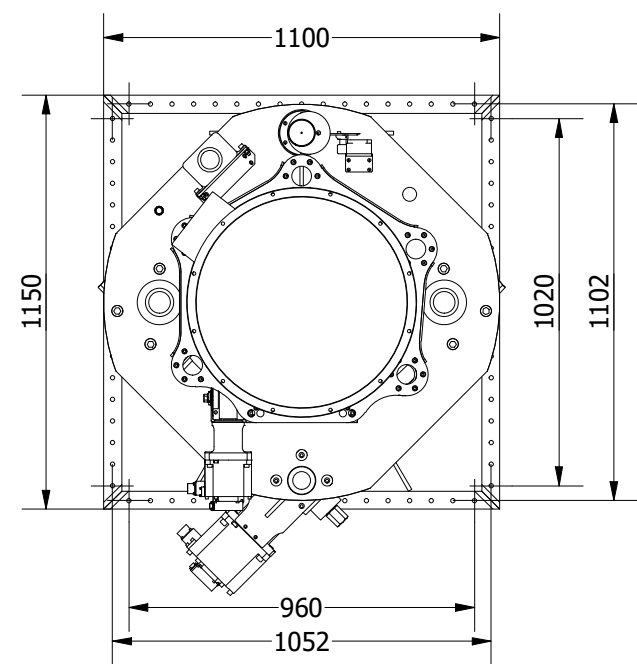
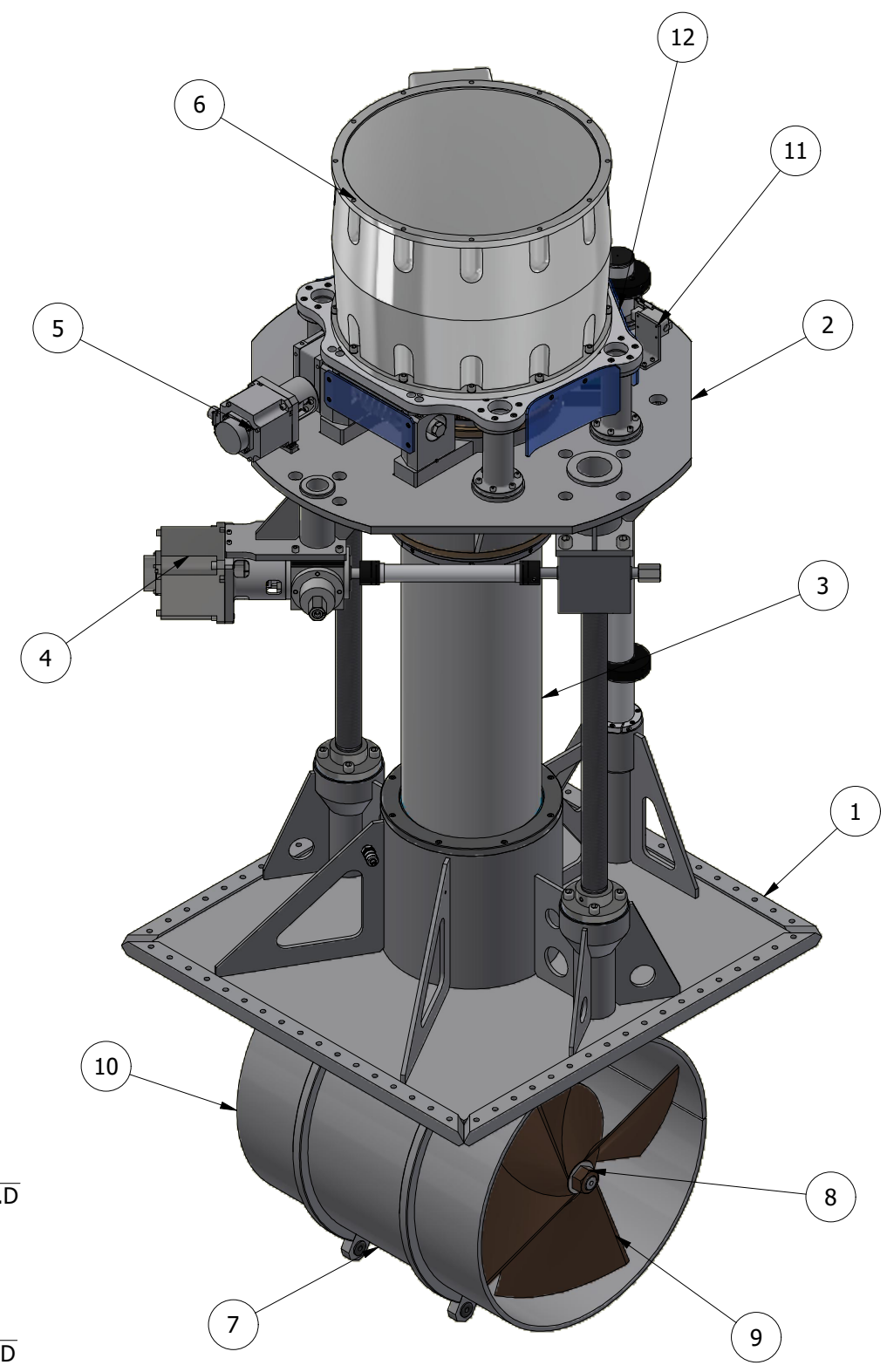

Title VERTICAL RETRACT AND ROTATE THRUSTER - ELECTRIC		Revision 1
Drawing No. E-0700-V-R		Date Drawn 31/03/2016
By LR		
Tel: +44 (0)1202 596630 www.oms.ltd		© Copyright. All rights to this drawing and design are the sole property of OMS Ltd. This drawing must not be copied, communicated or loaned to any third party without the written consent of OMS Ltd.