

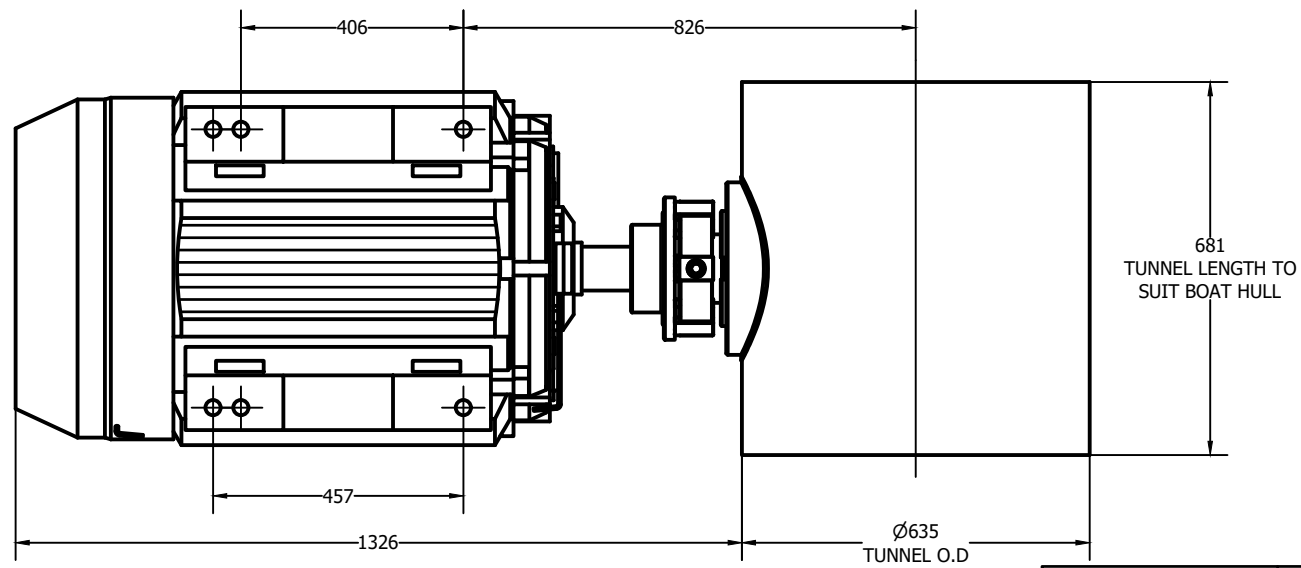

ITEM	QTY	DESCRIPTION
1	1	MOTOR ASSEMBLY
2	1	TUNNEL ASSEMBLY
3	1	POD ASSEMBLY
4	1	PROPELLER 1
5	1	PROPELLER 2

NOMINAL PROP DIA	600mm
POWER RANGE	99-142kw (133-190hp)
MIN / MAX THRUST	1188-1704kgf (2619-3757lbf)
WEIGHT APPROXIMATELY	812kg (1791lb)

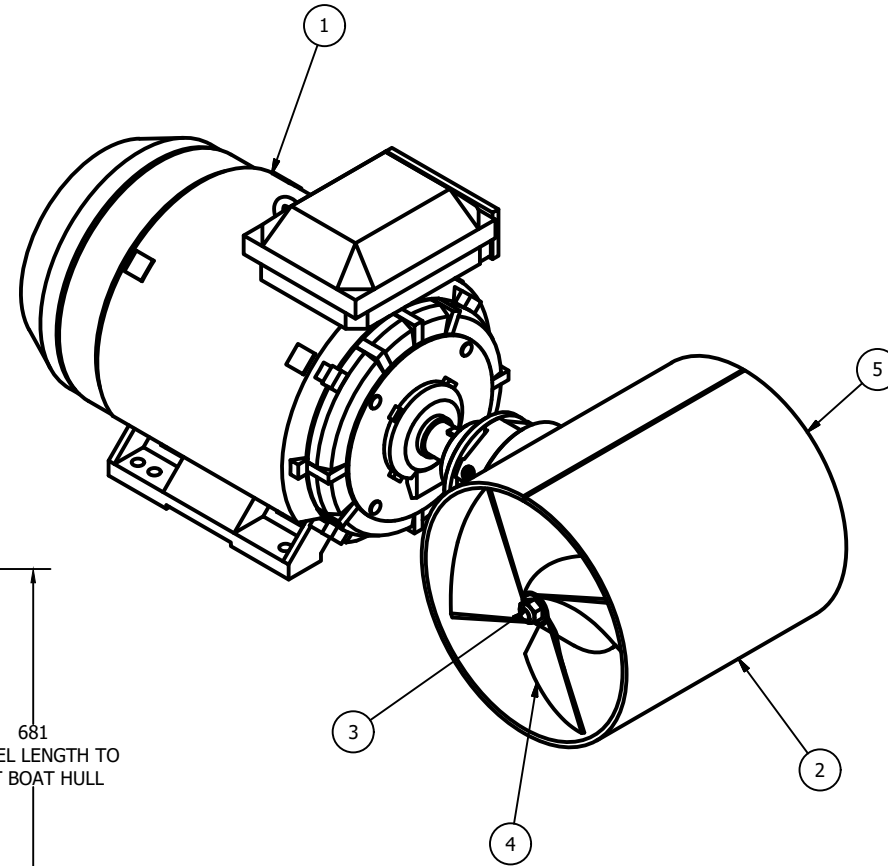
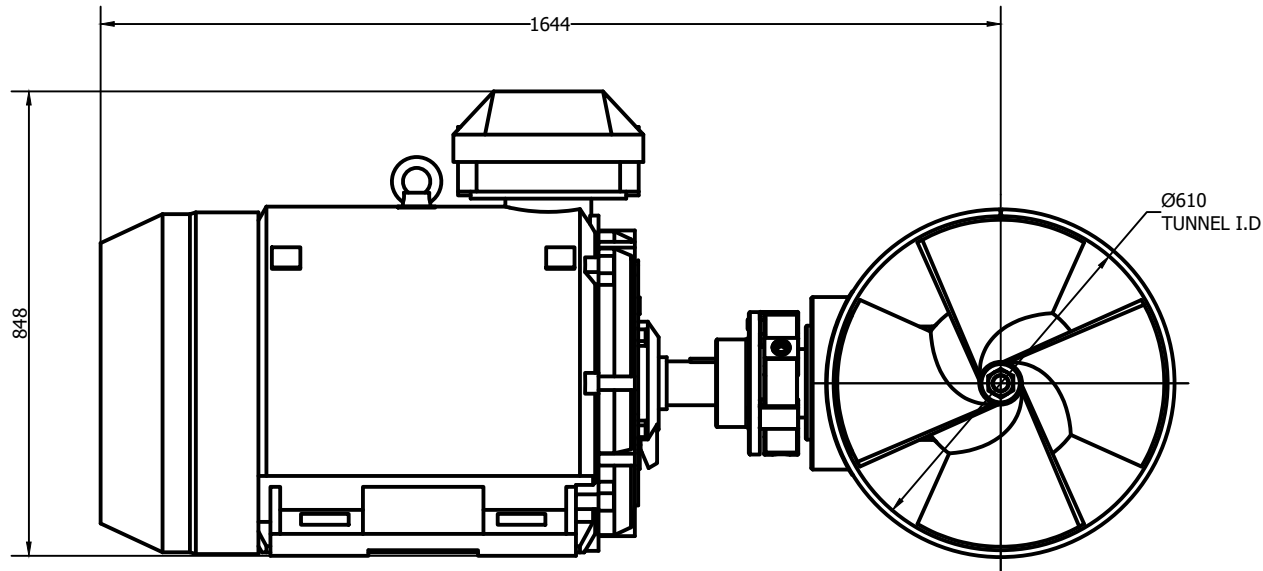

	Title				Revision		Dimensions in millimeters & degrees							
	TUNNEL THRUSTER - ELECTRIC				2		Gen. Tolerance ± 0.2							
Drawing No.			Material		Gen. Finish									
E-0600-T					3.2									
Sheet		Scale		Mass		Date Drawn		By		Modified Date	By	Cert.	Insp.	Grade
1 of 1		N.T.S @ A3		N/A		11/05/2015		LR		15/06/2018	LR			
© Copyright. All rights to this drawing and design are the sole property of Ocean Marine Systems Ltd. This drawing must not be copied, communicated or loaned to any third party without the written consent of Ocean Marine Systems Ltd.														

If in doubt ask!