

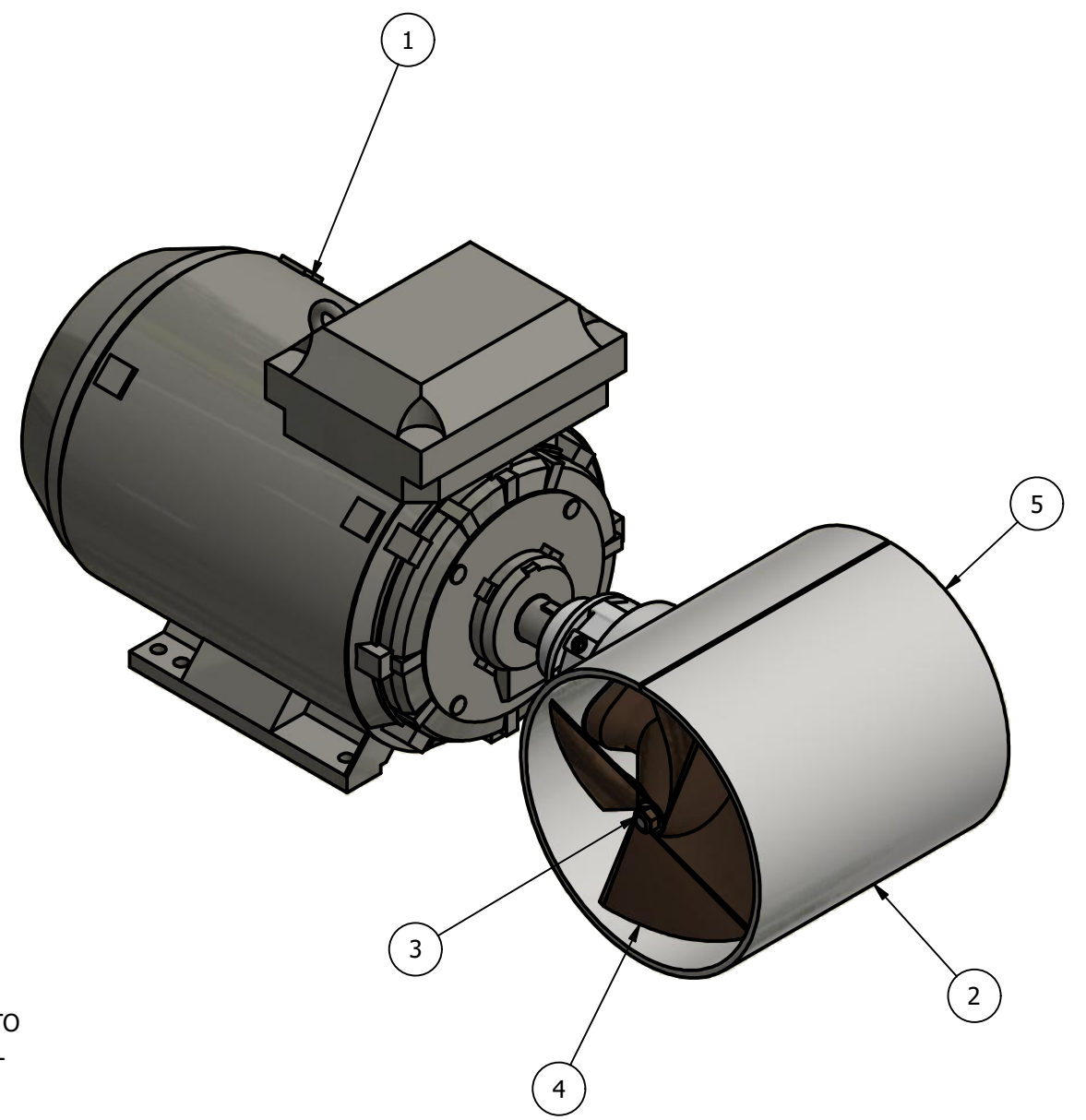

| ITEM | QTY | DESCRIPTION |
|------|-----|-----------------|
| 1 | 1 | MOTOR ASSEMBLY |
| 2 | 1 | TUNNEL ASSEMBLY |
| 3 | 1 | POD ASSEMBLY |
| 4 | 1 | PROPELLER 1 |
| 5 | 1 | PROPELLER 2 |

| | |
|------------------------------------|----------------------------|
| NOMINAL PROP DIA | 500mm |
| POWER RANGE | 63-99kw (84-133hp) |
| MIN / MAX THRUST | 756-1188kgf (1667-2619lbf) |
| WEIGHT APPROXIMATELY (EXCL TUNNEL) | 760 kg (1675 lb) |

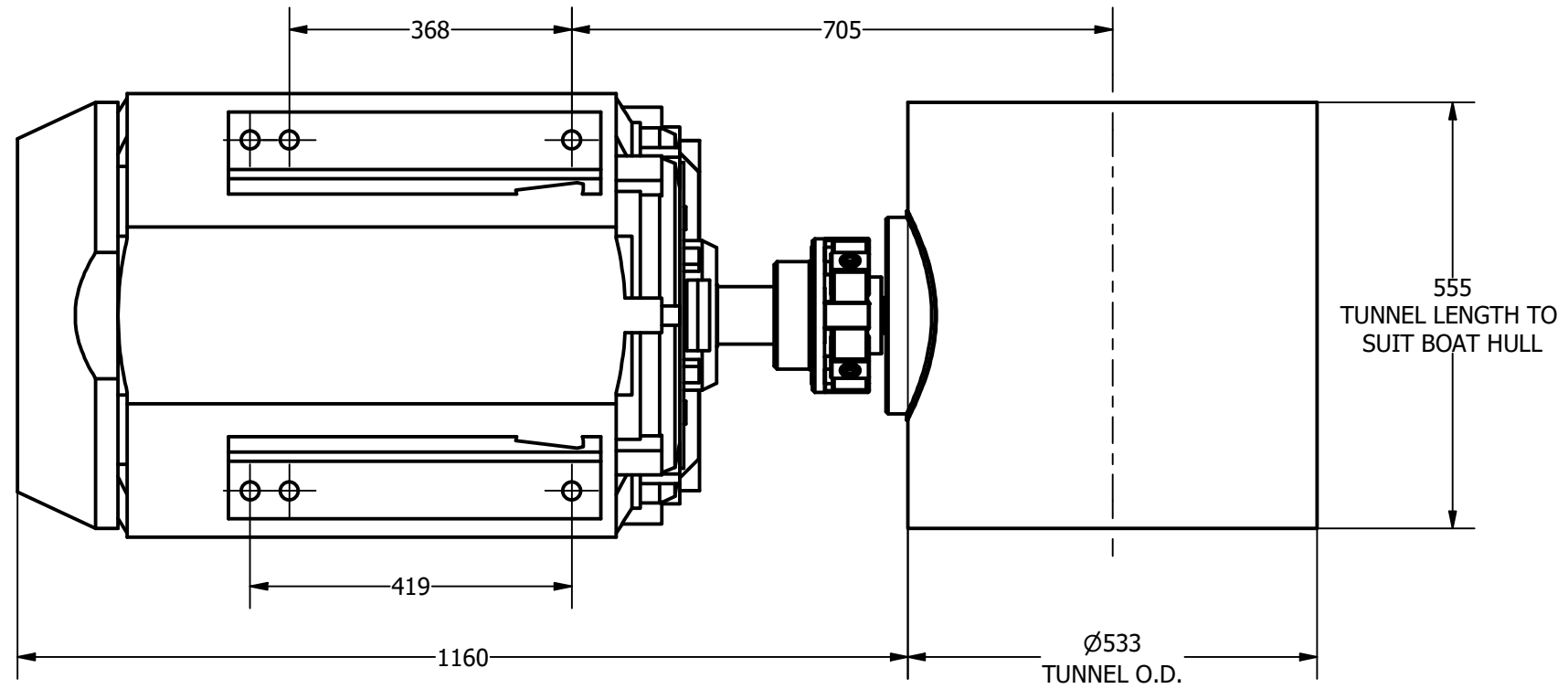
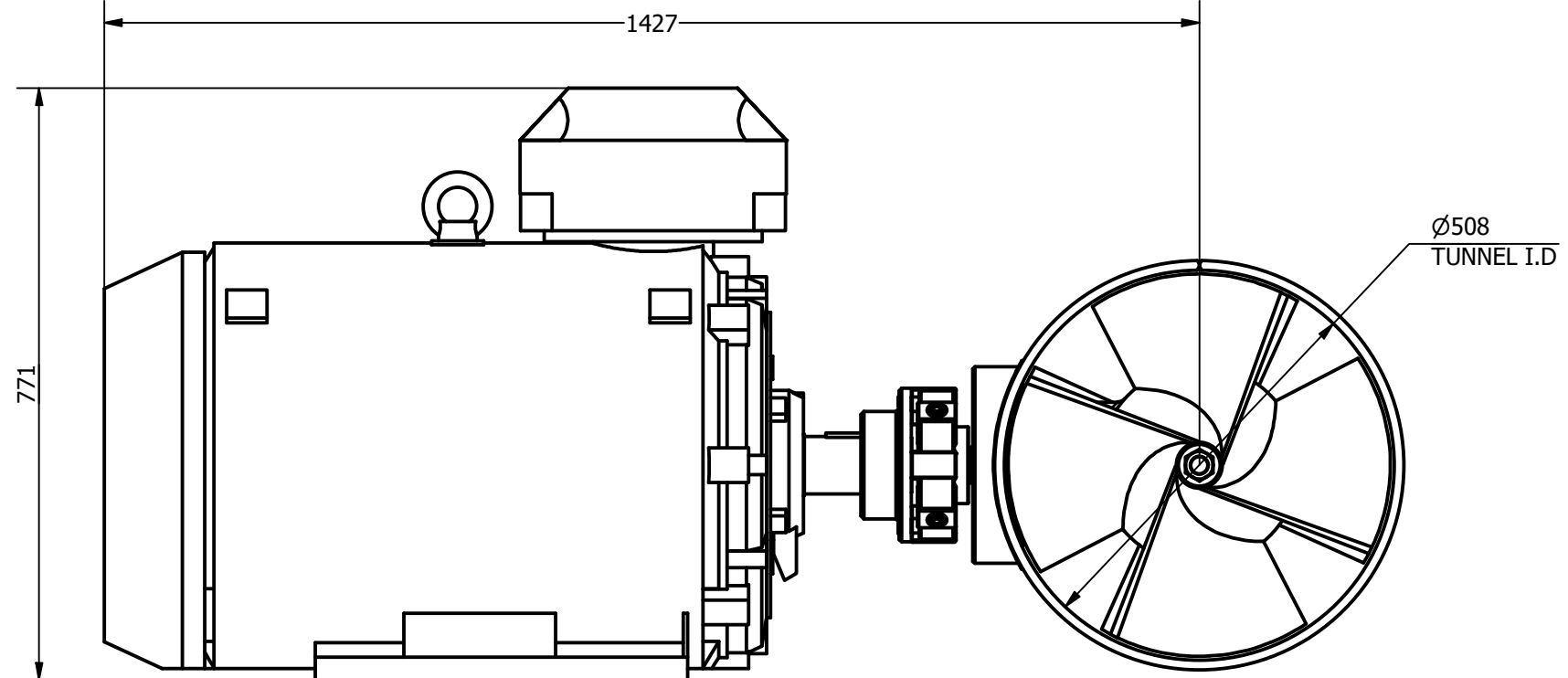

| | | | | | | | | | |
|--|----------------------------|------|------------|----------|---------------|--|-------|-------|-------|
|  <p>OCEAN MARINE SYSTEMS</p> <p>Tel: +44 (0)1202 596630 www.oceanmarinesystems.co.uk</p> | Title | | | Revision | | Dimensions in millimeters & degrees | | | |
| | TUNNEL THRUSTER - ELECTRIC | | | 1 | | Gen. Tolerance ± 0.2 Gen. Finish 3.2 | | | |
| | Drawing No. | | Material | Finish | |  <i>If in doubt ask!</i> | | | |
| | E-0500-T | | | | | | | | |
| Sheet | Scale | Mass | Date Drawn | By | Modified Date | By | Cert. | Insp. | Grade |
| 1 of 1 | N.T.S @ A3 | N/A | 02/02/2016 | LR | 27/01/2021 | BW | | | |

© Copyright. All rights to this drawing and design are the sole property of Ocean Marine Systems Ltd. This drawing must not be copied, communicated or loaned to any third party without the written consent of Ocean Marine Systems Ltd.