

ITEM	QTY	DESCRIPTION
1	1	MOUNTING BASE ASSEMBLY
2	1	LIFT PLATE ASSEMBLY
3	1	RETRACT TUBE ASSEMBLY
4	1	LIFTING SCREW ASSEMBLY
5	1	MOTOR ASSEMBLY
6	1	TUNNEL ASSEMBLY
7	1	POD ASSEMBLY
8	1	PROPELLER 1
9	1	PROPELLER 2
10	2	PROXIMITY SENSOR

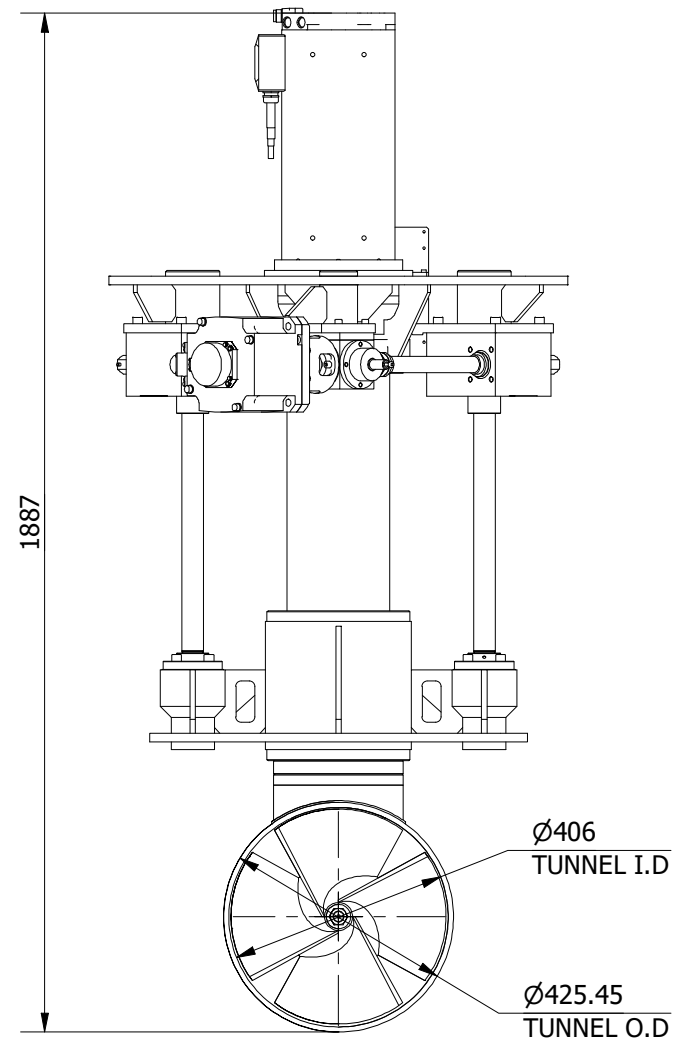

THIS THRUSTER REQUIRES A SUITABLY SIZED LIQUID COOLING SYSTEM FOR THE MAIN DRIVE MOTOR.

NOMINAL PROP DIA	400mm
POWER RANGE	36-63kw (48-85hp)
MIN / MAX THRUST	432-756kgf (952-1667lbf)
WEIGHT APPROXIMATELY	350kg (772lb)

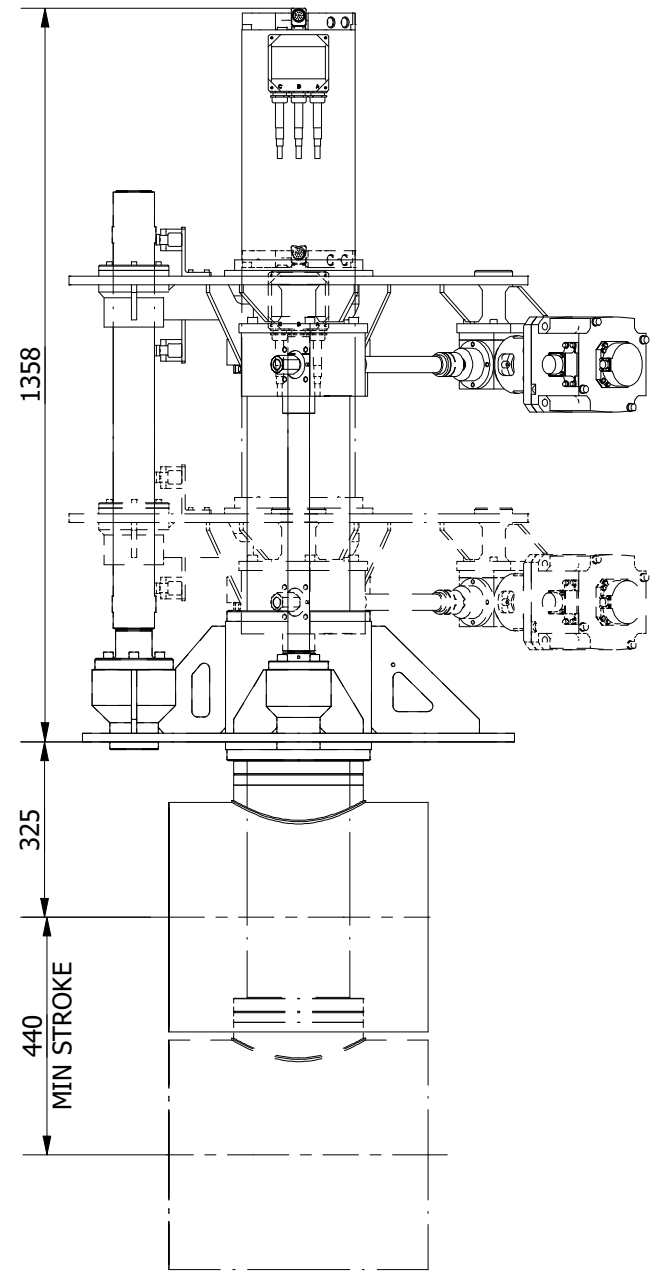
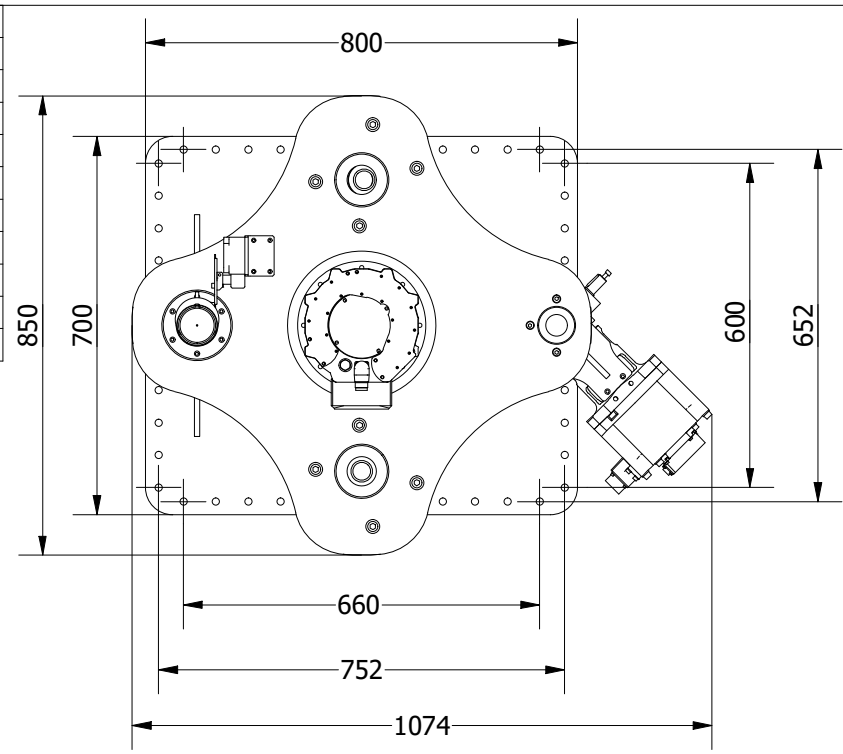
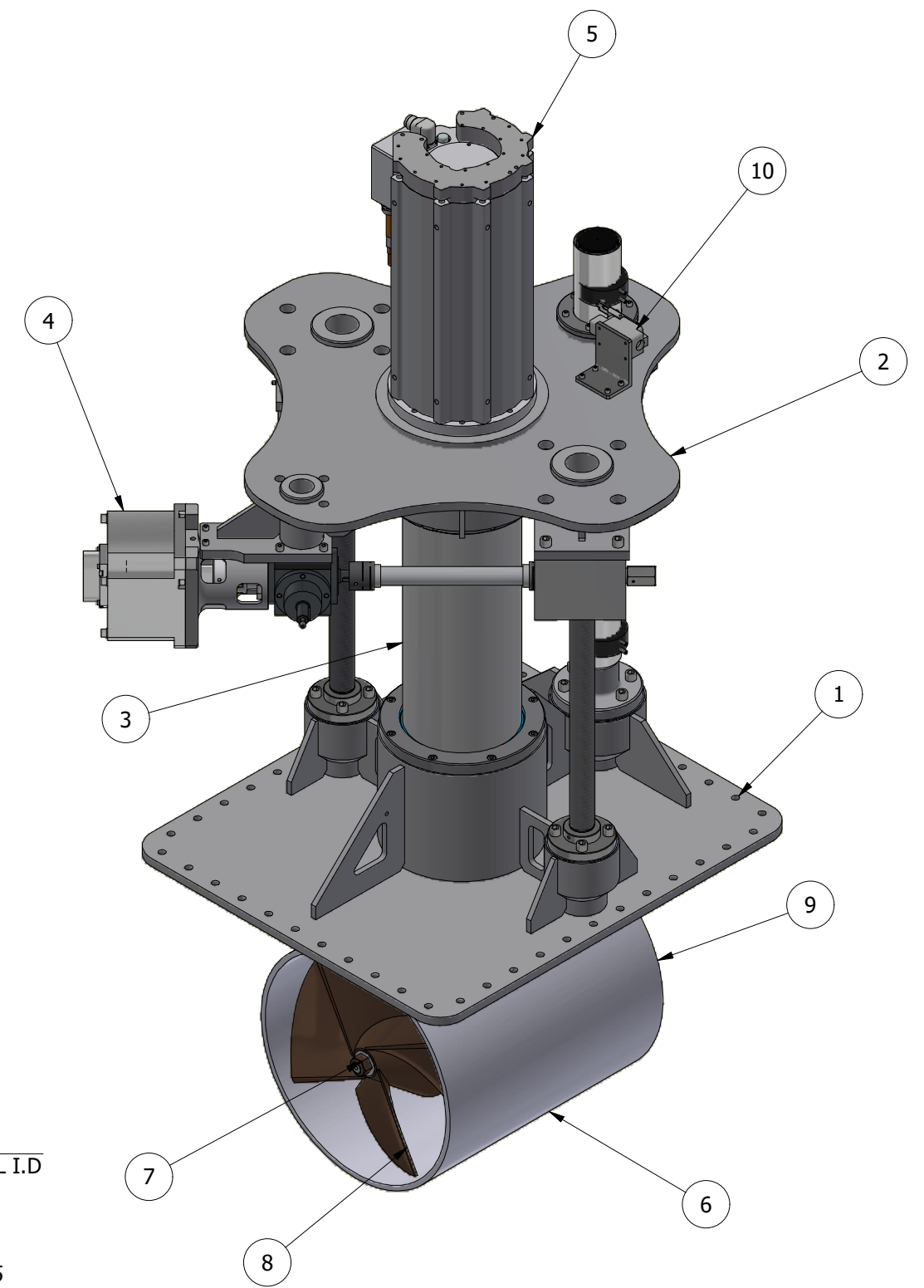

OMS
Ocean Marine Systems

Title ELECTRICAL VERTICAL RETRACTING THRUSTER		Revision 1
Drawing No. E-0400-V		Date Drawn 03/03/2021
By BARNEY		
Tel: +44 (0)1202 596630 www.oms.ltd		© Copyright. All rights to this drawing and design are the sole property of OMS Ltd. This drawing must not be copied, communicated or loaned to any third party without the written consent of OMS Ltd.