

ITEM	QTY	DESCRIPTION
1	1	MOUNTING BASE ASSEMBLY
2	1	LIFT PLATE ASSEMBLY
3	1	RETRACT TUBE ASSEMBLY
4	1	LIFTING SCREW ASSEMBLY
5	1	MOTOR ASSEMBLY
6	1	TUNNEL ASSEMBLY
7	1	POD ASSEMBLY
8	1	PROPELLER 1
9	1	PROPELLER 2
10	2	PROXIMITY SENSOR

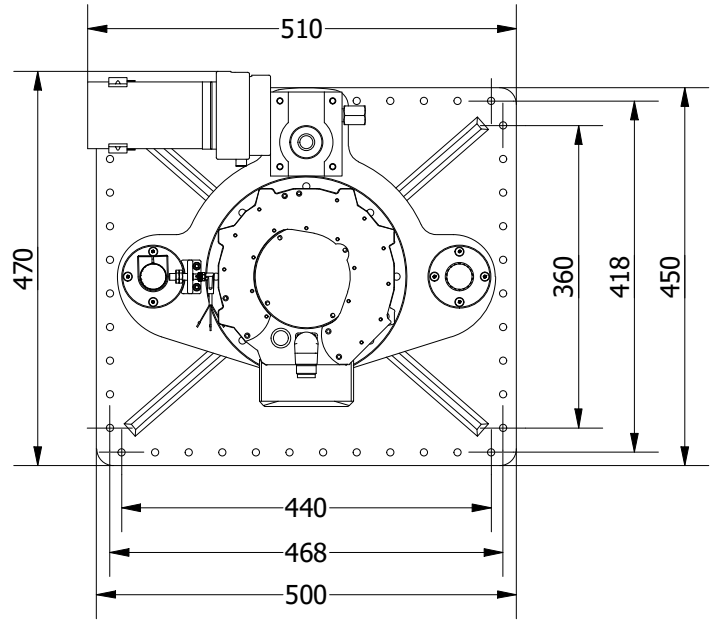

THIS THRUSTER REQUIRES A SUITABLY SIZED LIQUID COOLING SYSTEM FOR THE MAIN DRIVE MOTOR.

NOMINAL PROP DIA	300mm
POWER RANGE	25-36kw (34-48hp)
MIN / MAX THRUST	300-432kgf (661-952lbf)
WEIGHT APPROXIMATELY	110kg (220lb)

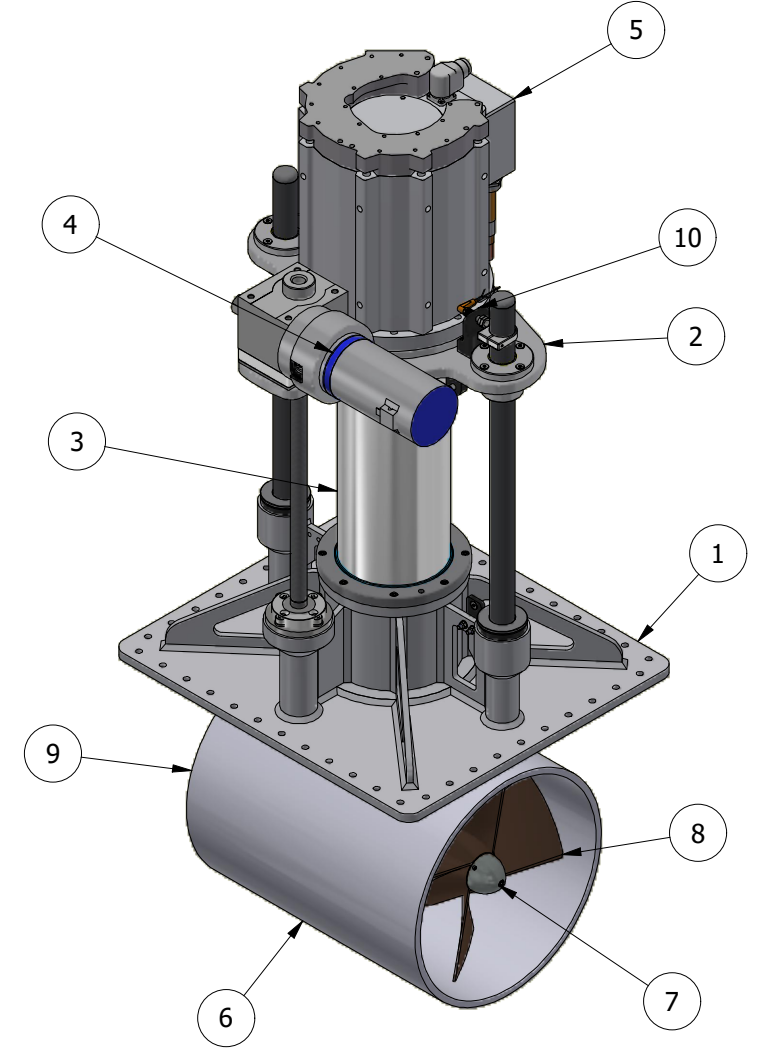
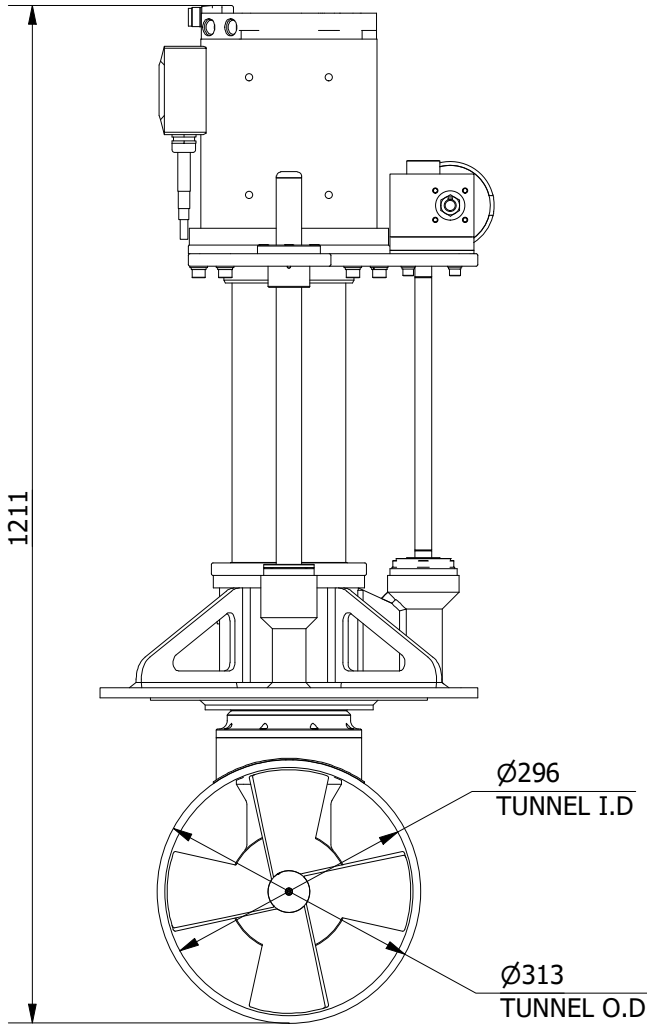
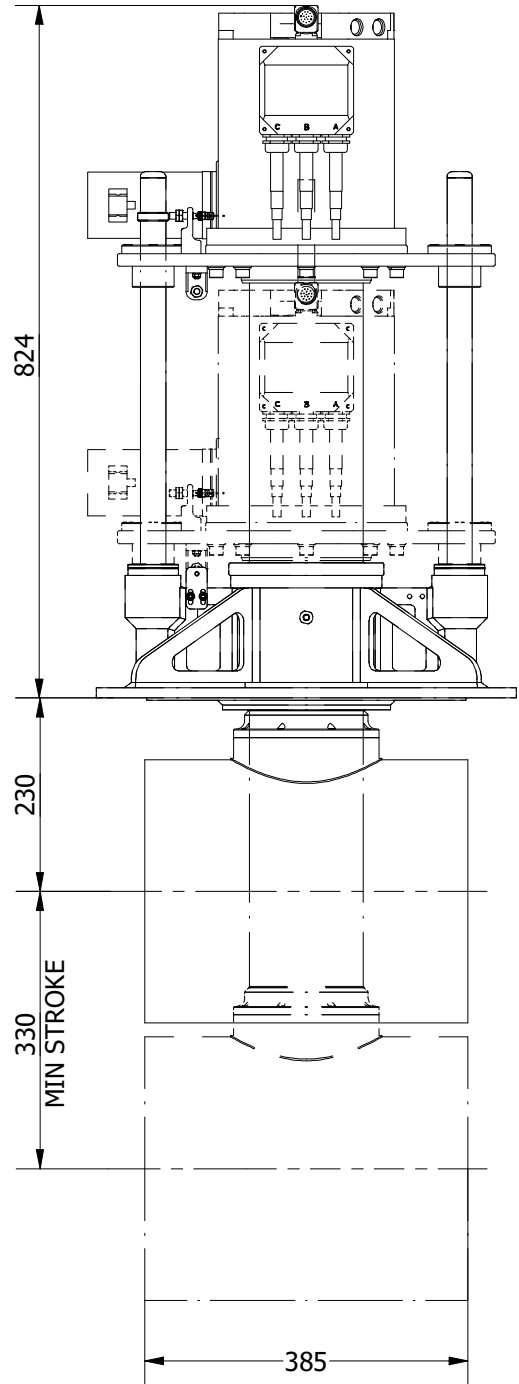

Title VERTICAL RETRACTING THRUSTER - ELECTRIC		Revision 2
Drawing No. E-0300-V	Date Drawn 13/08/2019	By CR
Tel: +44 (0)1202 596630 www.oms.ltd		© Copyright. All rights to this drawing and design are the sole property of OMS Ltd. This drawing must not be copied, communicated or loaned to any third party without the written consent of OMS Ltd.